

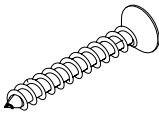







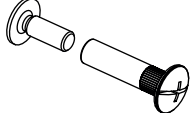
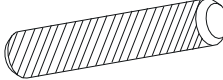
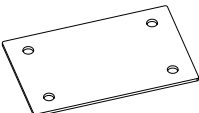

# ZAST 02/03

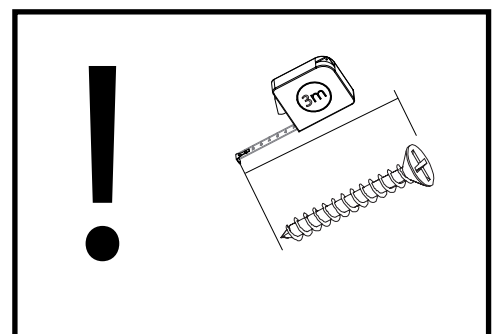
<p><b>WT18</b> x 5 4x30</p> 	<p><b>ZS1</b> x 3 Ø13</p> 	<p><b>ZS8</b> x 3</p> 
<p><b>K2</b> x 3 8x60</p> 	<p><b>PM1</b> x 1</p> 	<p><b>WT2</b> x 4 3,5x16</p> 

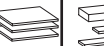

# ZAST 02/03

	CODE				
①	Zast02_02	900	372	1	1/1
②	Zast02_01	1000	400	1	1/1

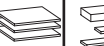
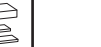
	CODE				
①	Zast03_02	900	372	1	1/1
②	Zast03_01	400	1000	1	1/1

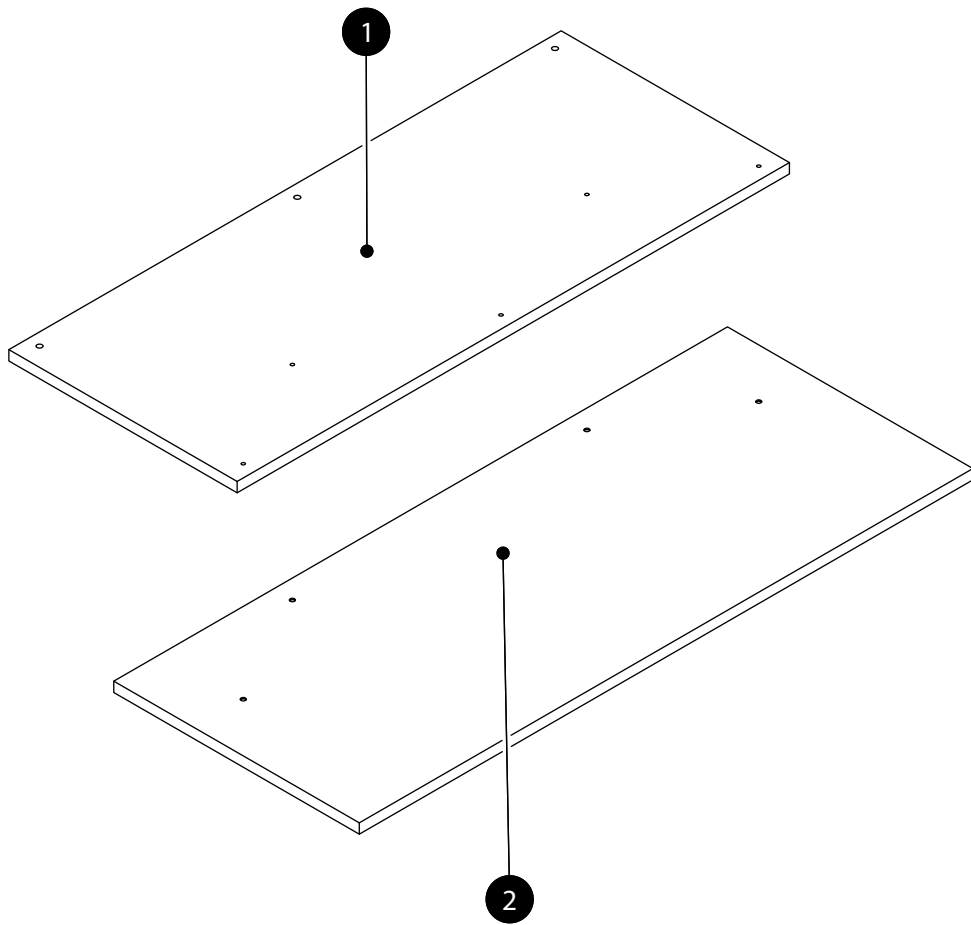

1.

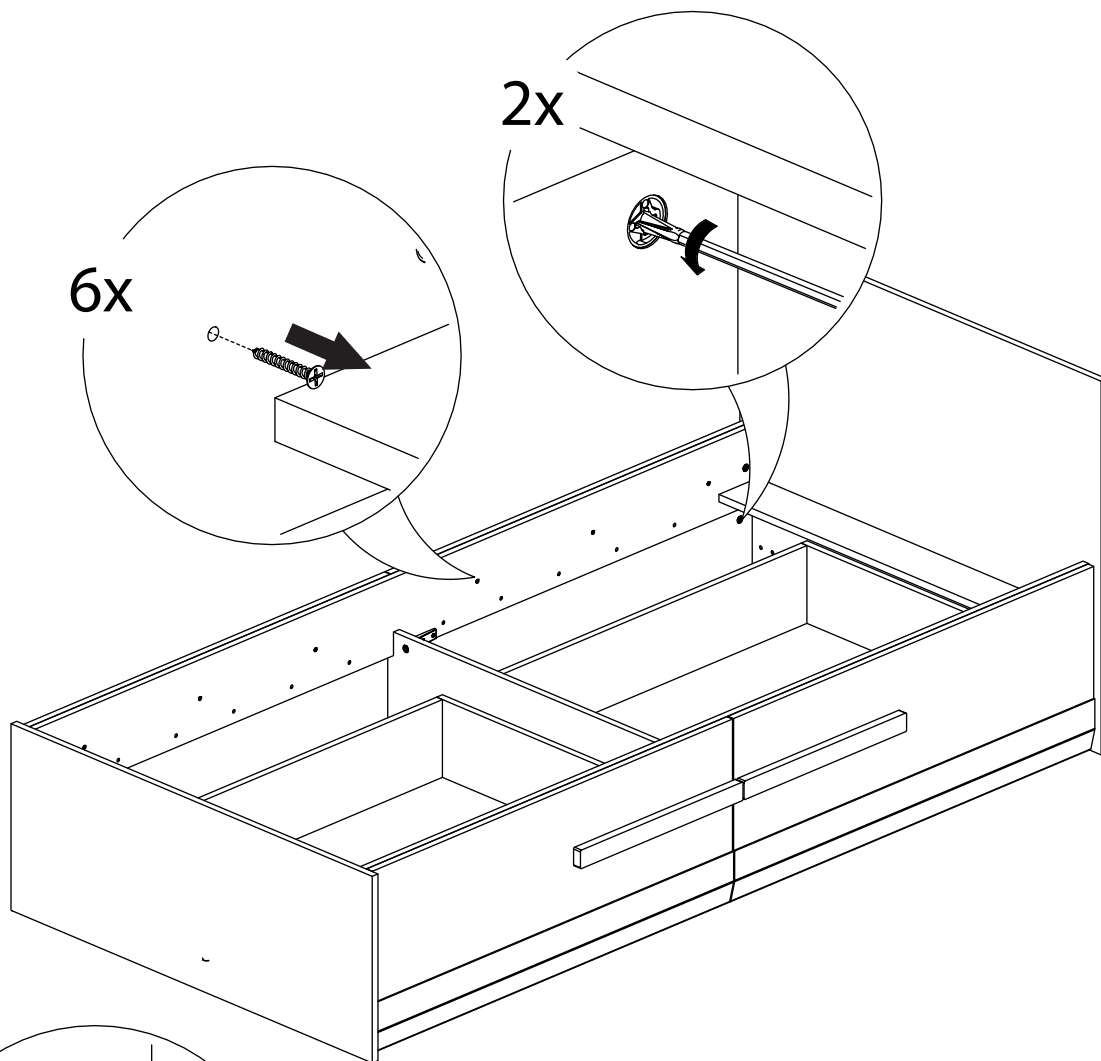

2.

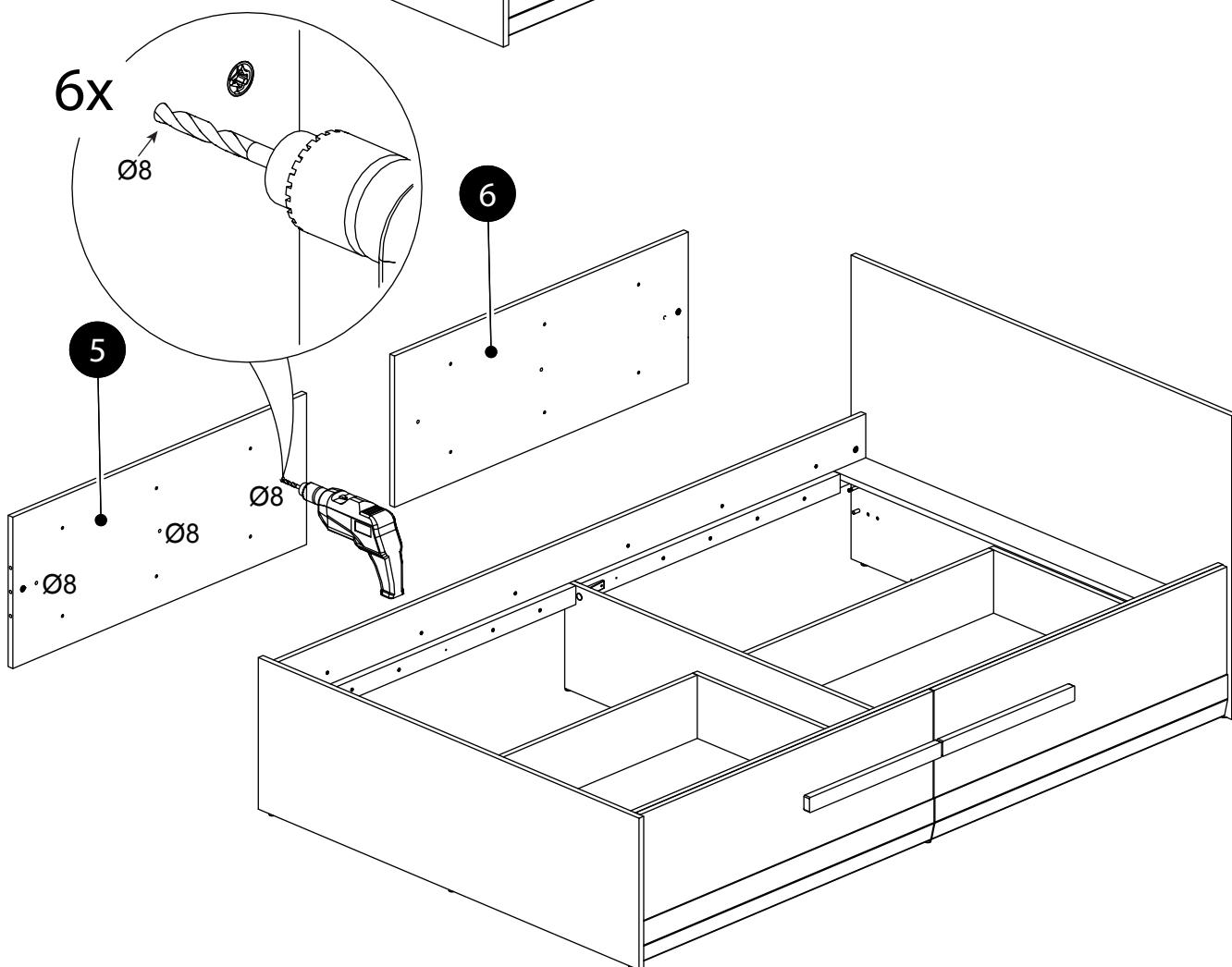

3.

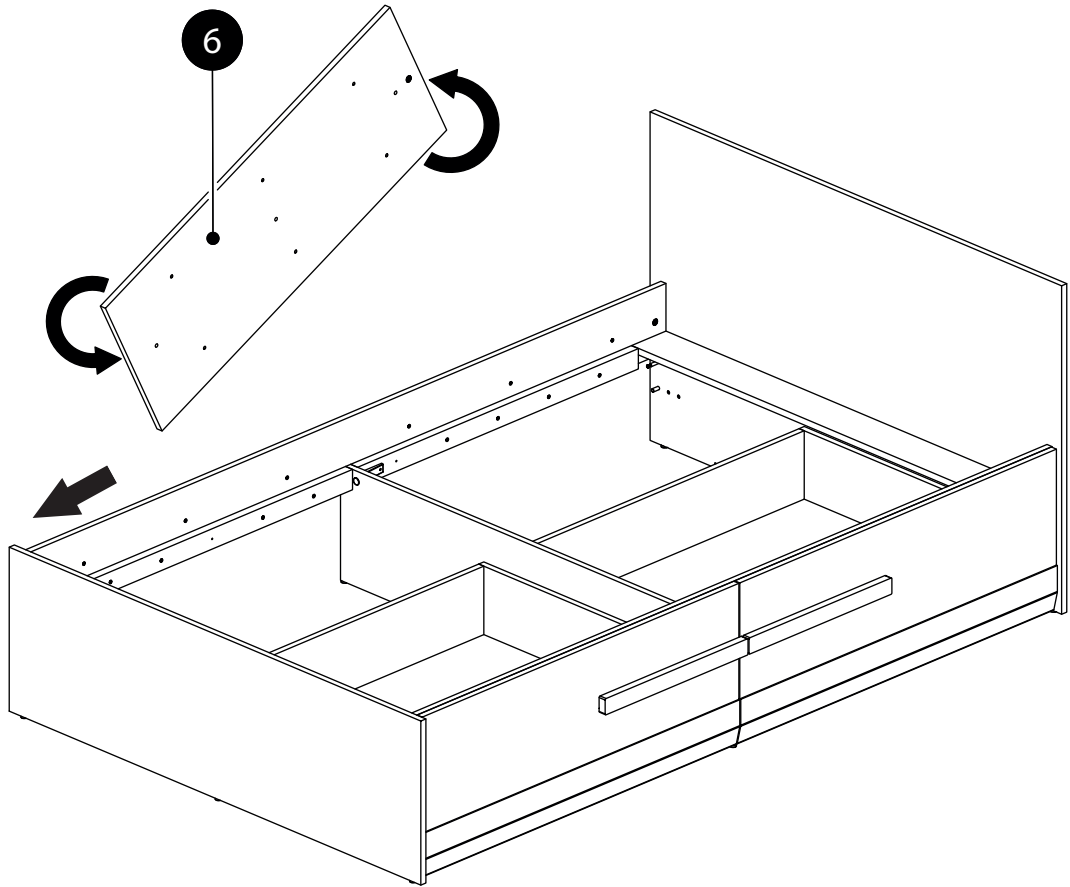

4.

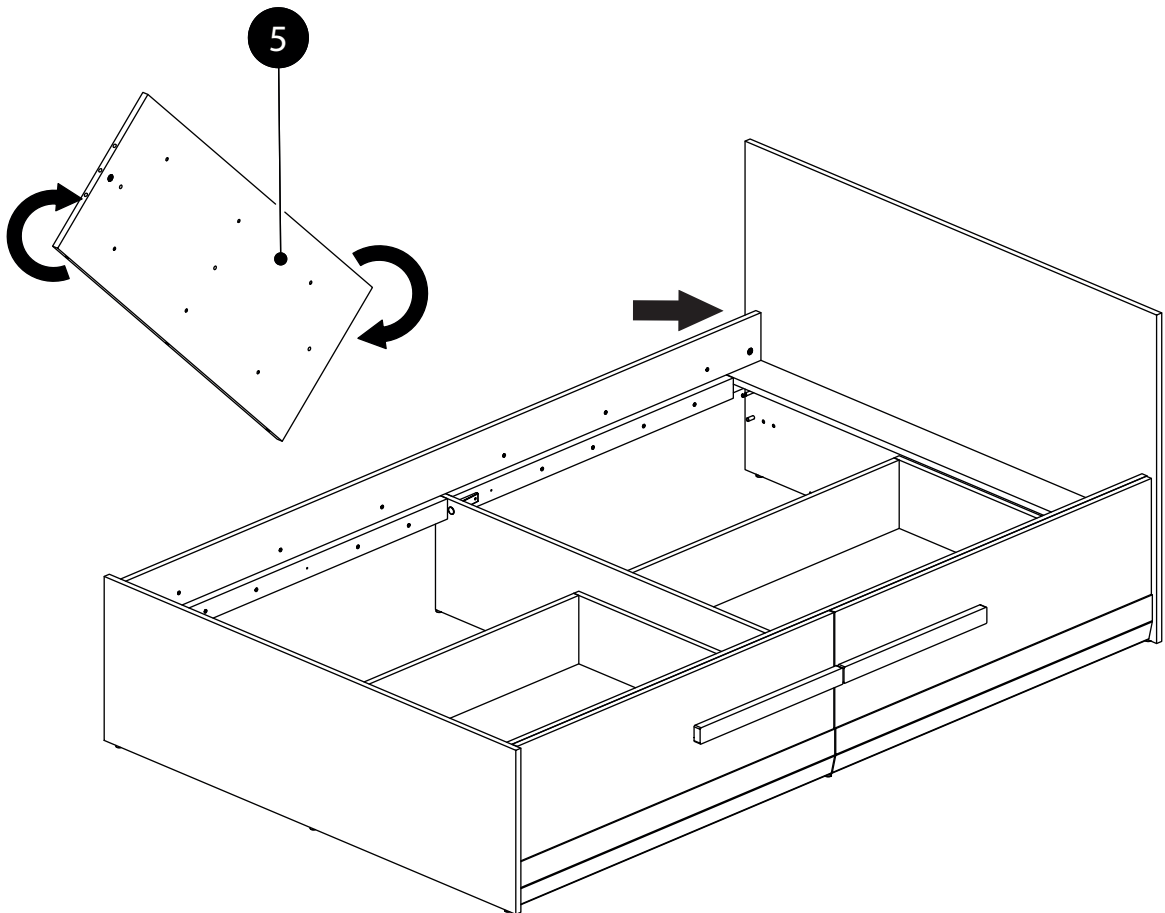

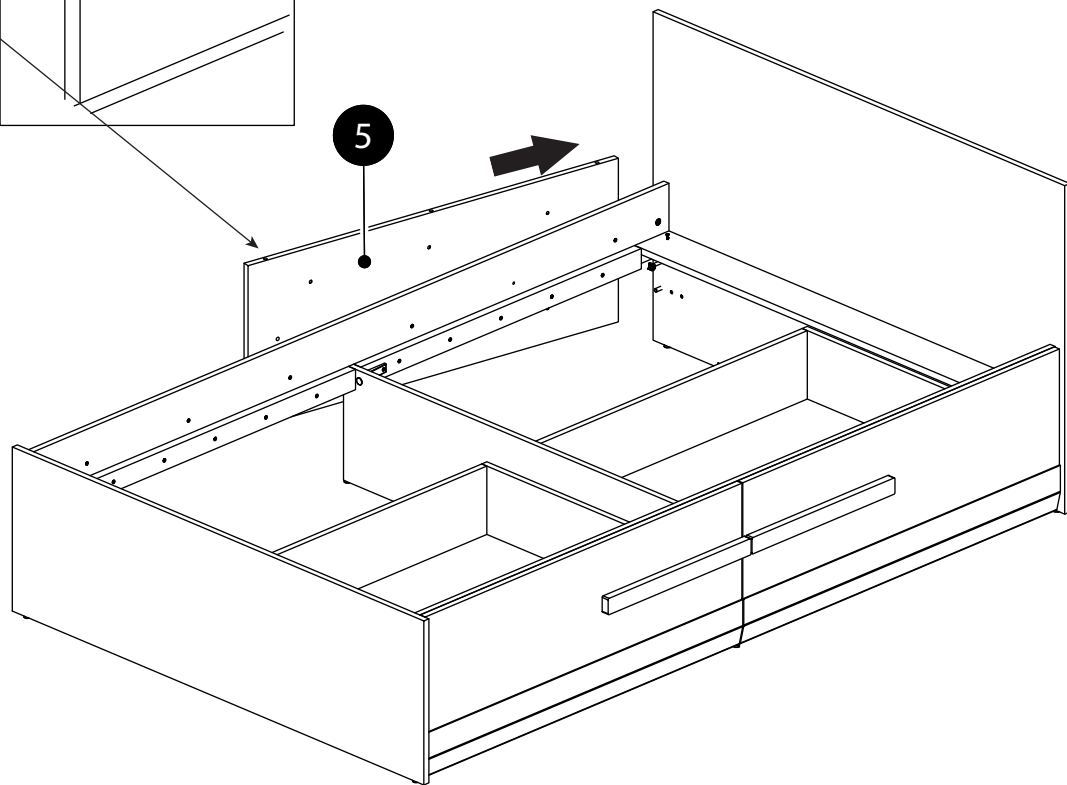
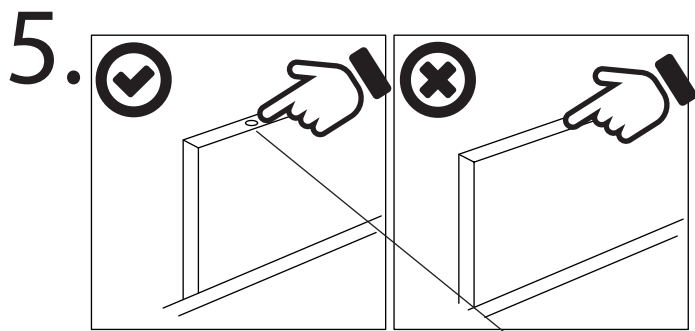

6.

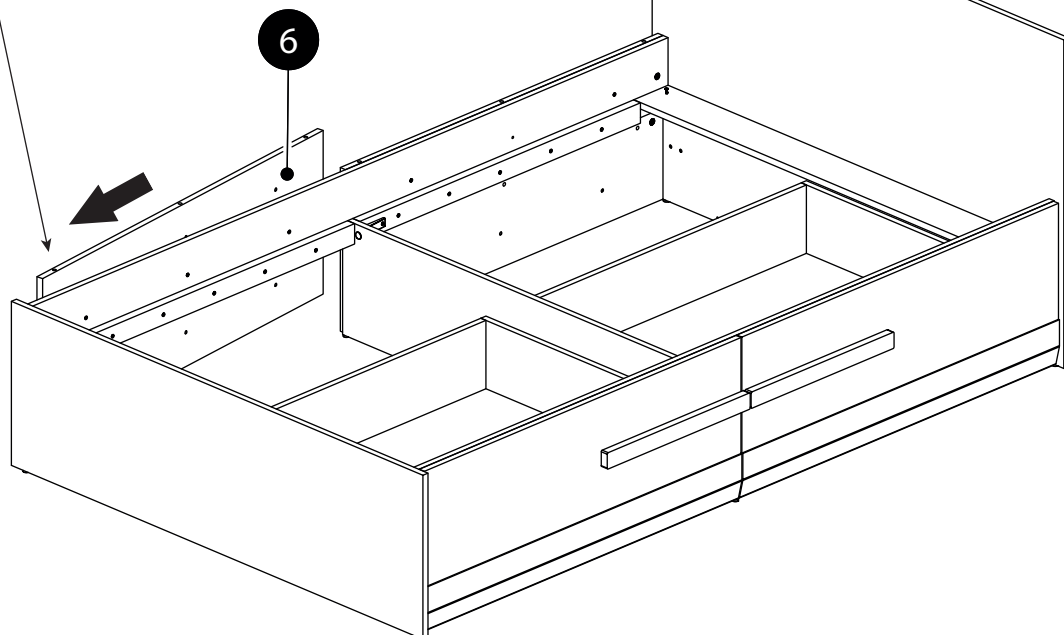
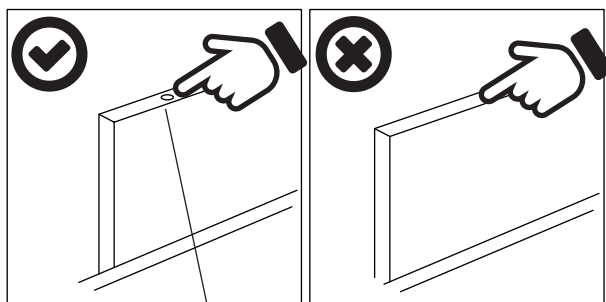

7.

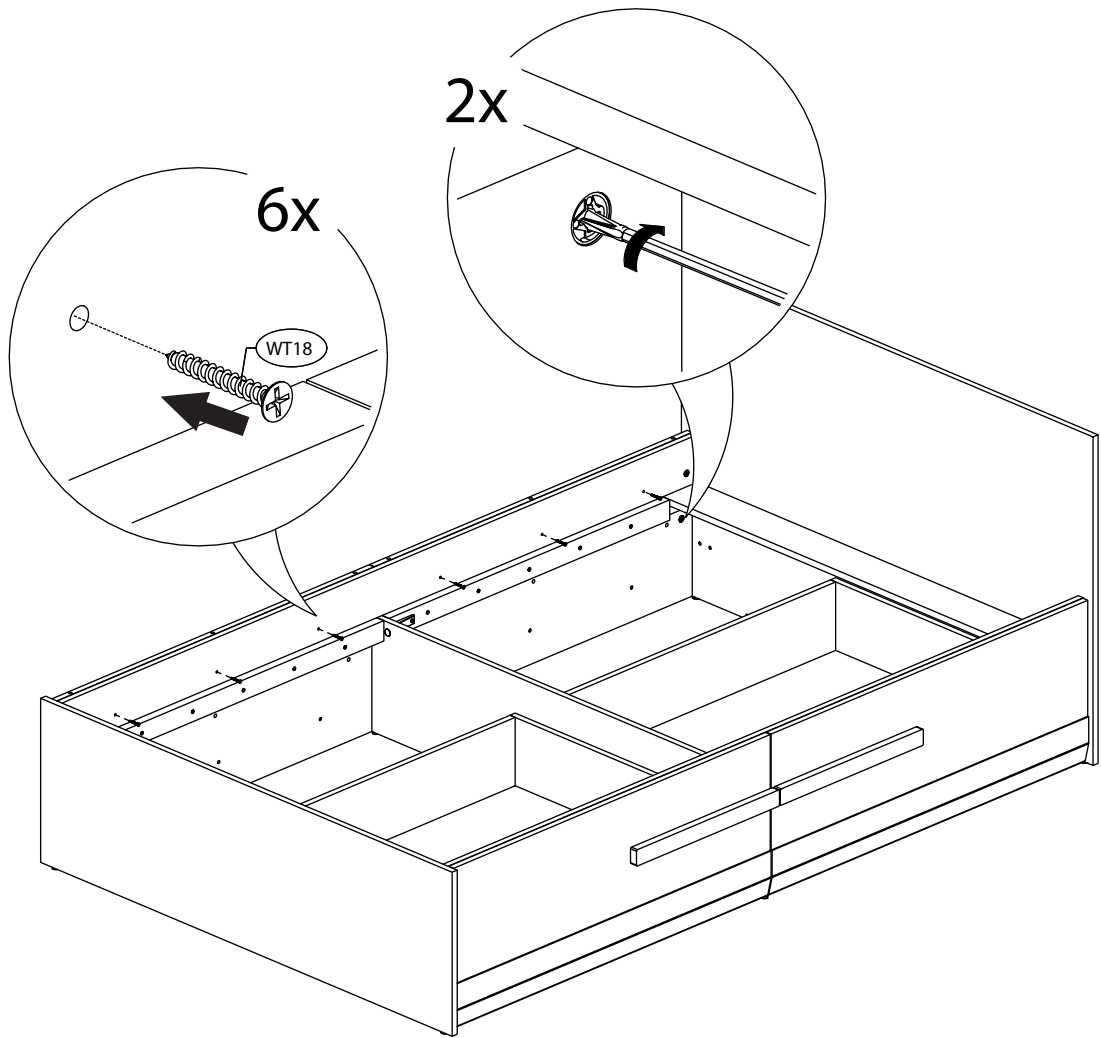

8.

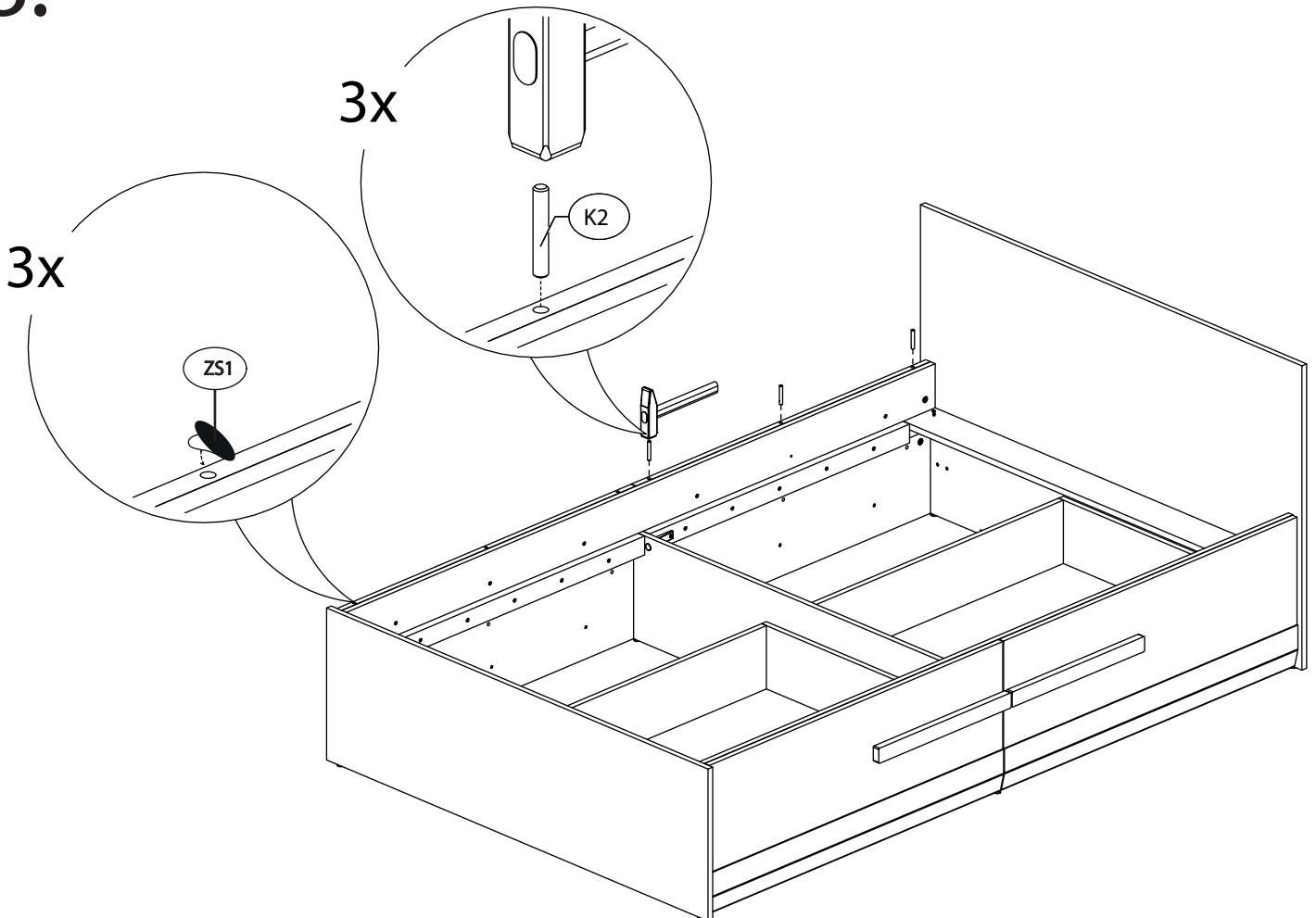



9.

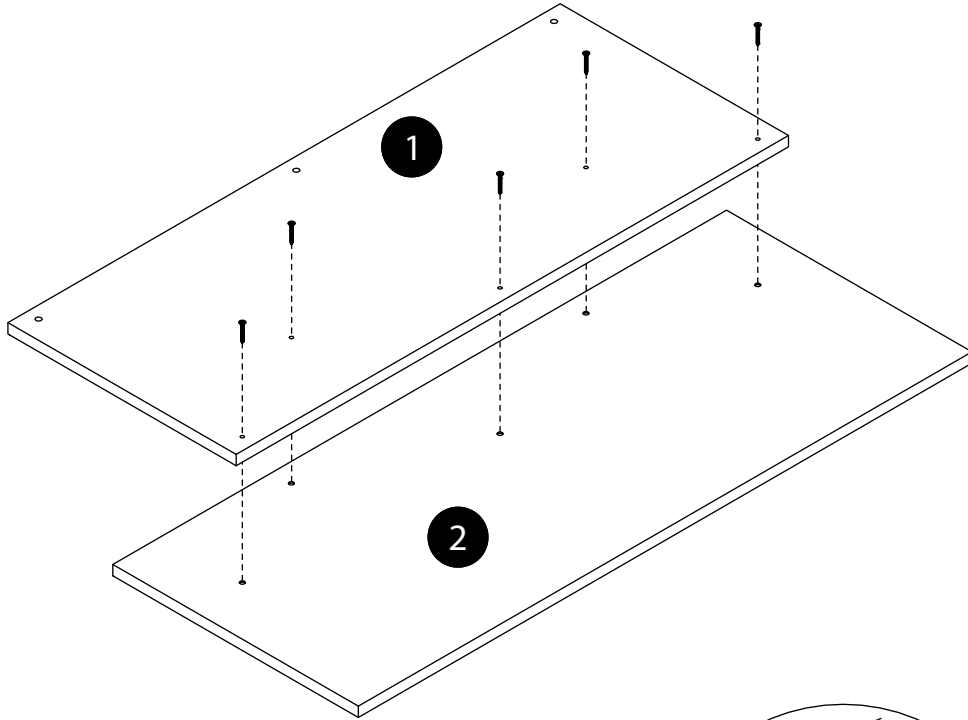
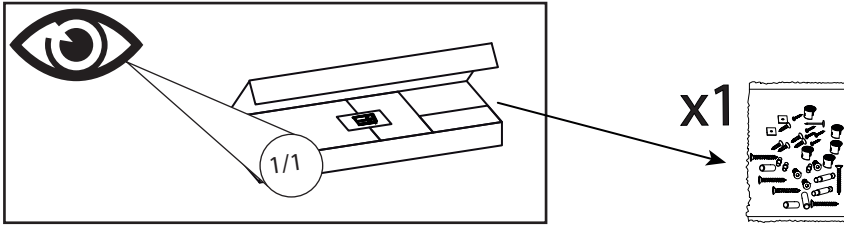

10.

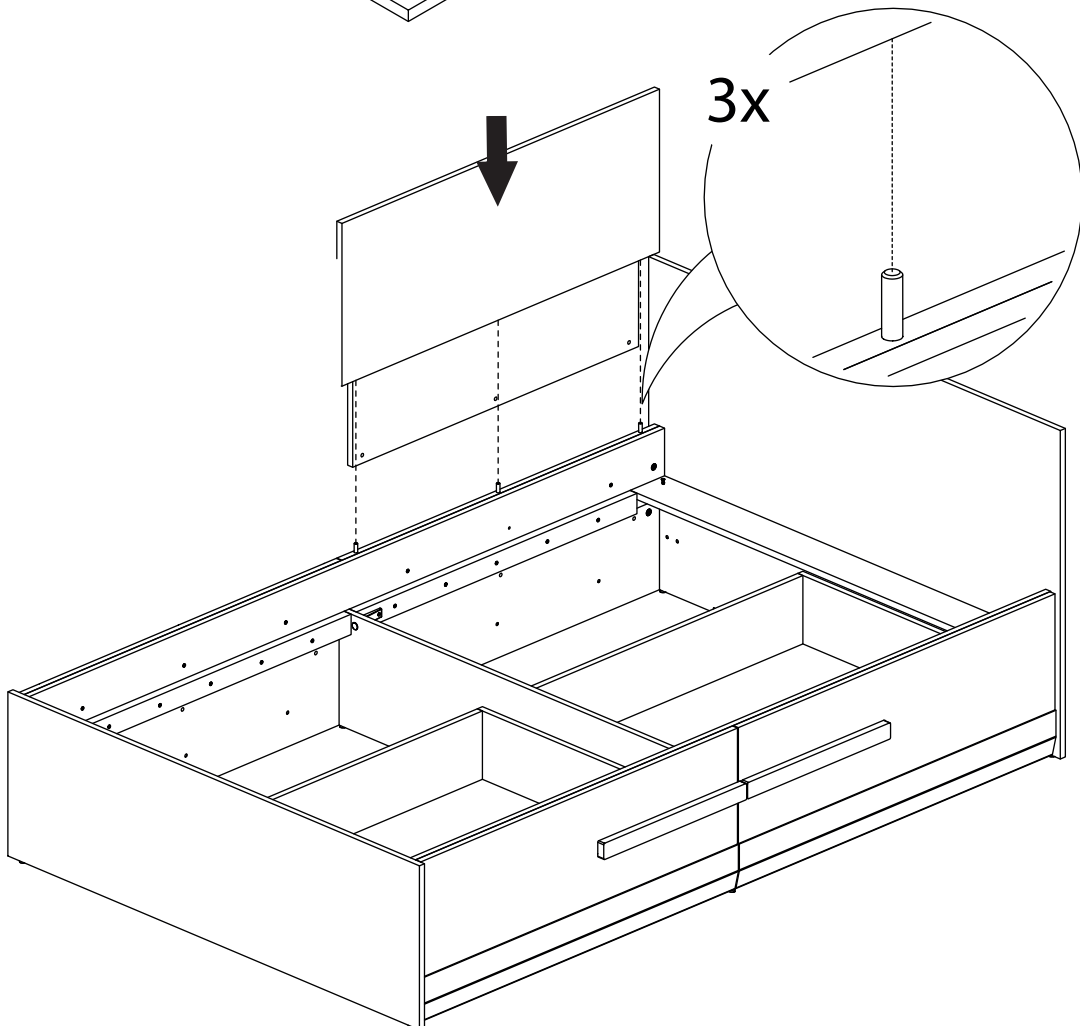

11.

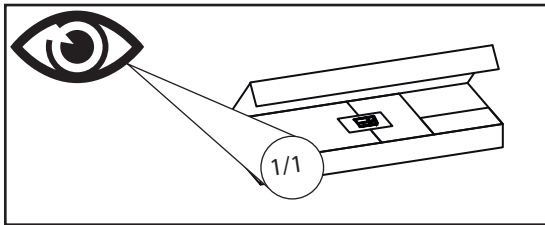
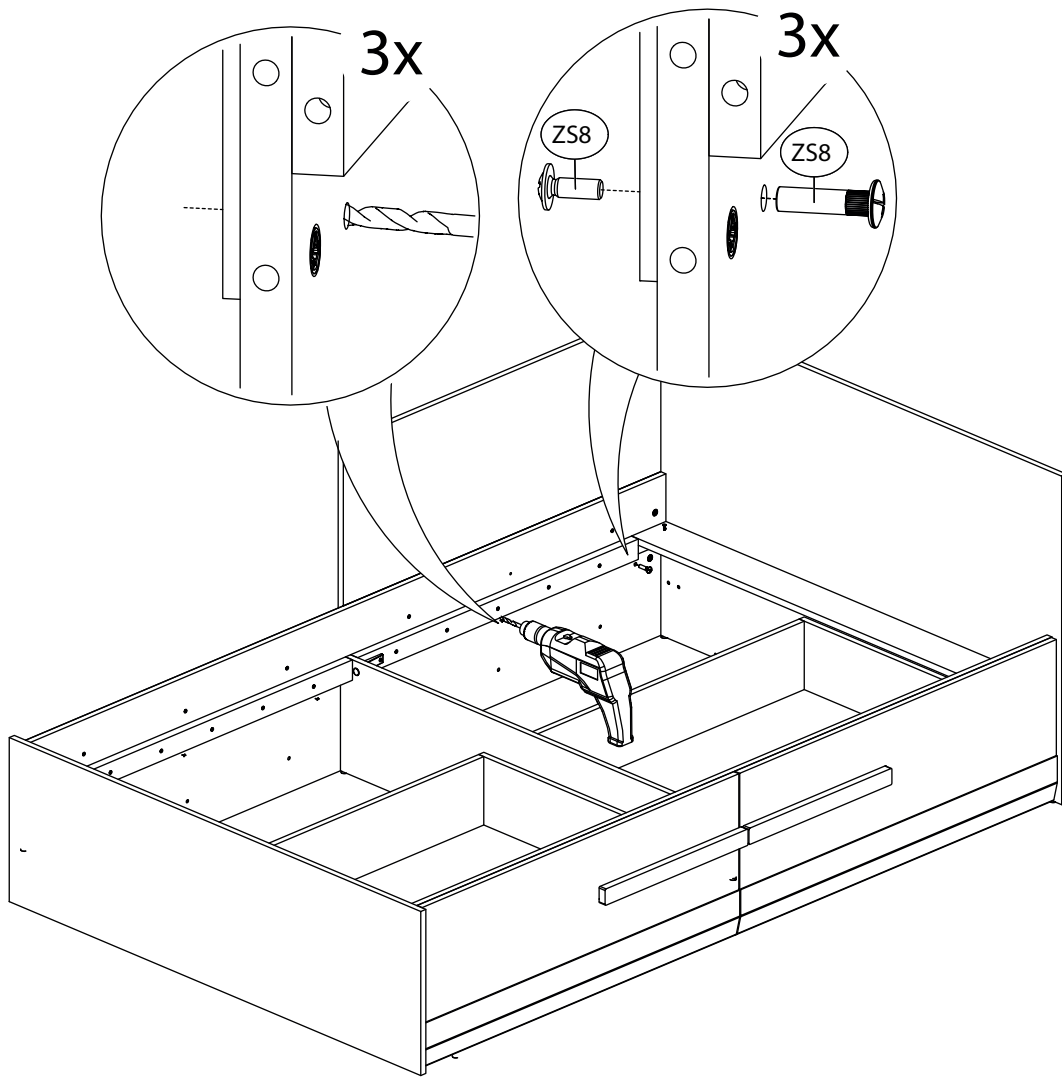

x 2 =

