

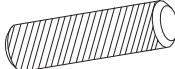

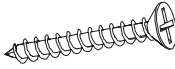

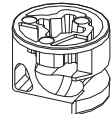

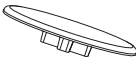







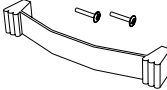

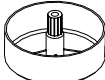

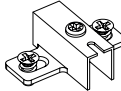
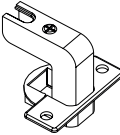
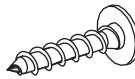
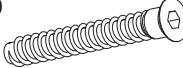
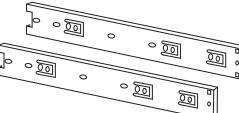

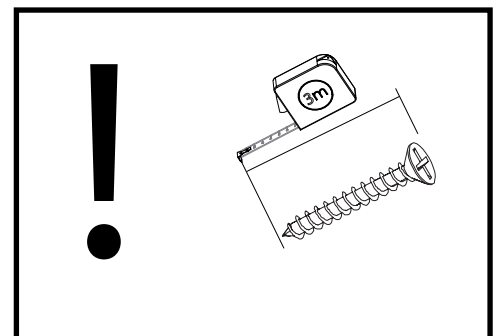
# MOCCA 09

<p><b>K1</b> x 36 8x32</p> 	<p><b>WT18</b> x 16 4x30</p> 	<p><b>B2</b> x 52 h-12</p> 
<p><b>ZM1</b> x 44 Ø18</p> 	<p><b>WT1</b> x 14 3,5x15</p> 	<p><b>ZD1</b> x 4 L68</p> 
<p><b>ZJ1</b> x 44 L-43</p> 	<p><b>PO2</b> x 8</p> 	<p><b>SP</b> x 12</p> 
<p><b>UUR</b> x 5 L-128</p> 	<p><b>WE7</b> x 18 6,3x13ES</p> 	<p>x 1</p> 
<p><b>SMO</b> x 6 Ø50 h25</p> 	<p><b>ZS1</b> x 4 Ø13</p> 	<p><b>PK6</b> x 4</p> 
<p><b>ZP10</b> x 4</p> 	<p><b>WT9</b> x 54 3x16</p> 	<p><b>KT1</b> x 10 6,3x50</p> 
<p><b>P1</b> x 3 L-350</p> 	<p><b>GW1</b> x 12 1,4x25</p> 	<p><b>WS1</b> x 3 L-350</p> 



# MOCCA 09

	CODE				
1	Mocca09HDF_02	1623	296	3	2/3
2	Mocca09_03	878	400	2	1/3
4	Mocca09_10	180	350	3	1/3
5	Mocca09HDF_01	613	355	3	2/3
6	Mocca09_09	658	230	3	1/3
7	Mocca09_17	1648	88	2	3/3
8	Mocca09_08	384	696	2	1/3
9	Mocca09_13	1612	96	2	2/3
10	Mocca09_12	180	586	3	2/3
11	Mocca09_16	912	88	2	3/3

	CODE				
12	Mocca09_07	468	367	2	2/3
13	Mocca09_05	878	368	1	1/3
14	Mocca09_06	878	368	1	1/3
15	Mocca09_11	180	350	3	1/3
16	Mocca09_02	1648	400	1	2/3
17	Mocca09_01	1648	400	1	2/3
18	Mocca09_14	685	92	2	1/3
19	Mocca09_15	643	92	1	1/3

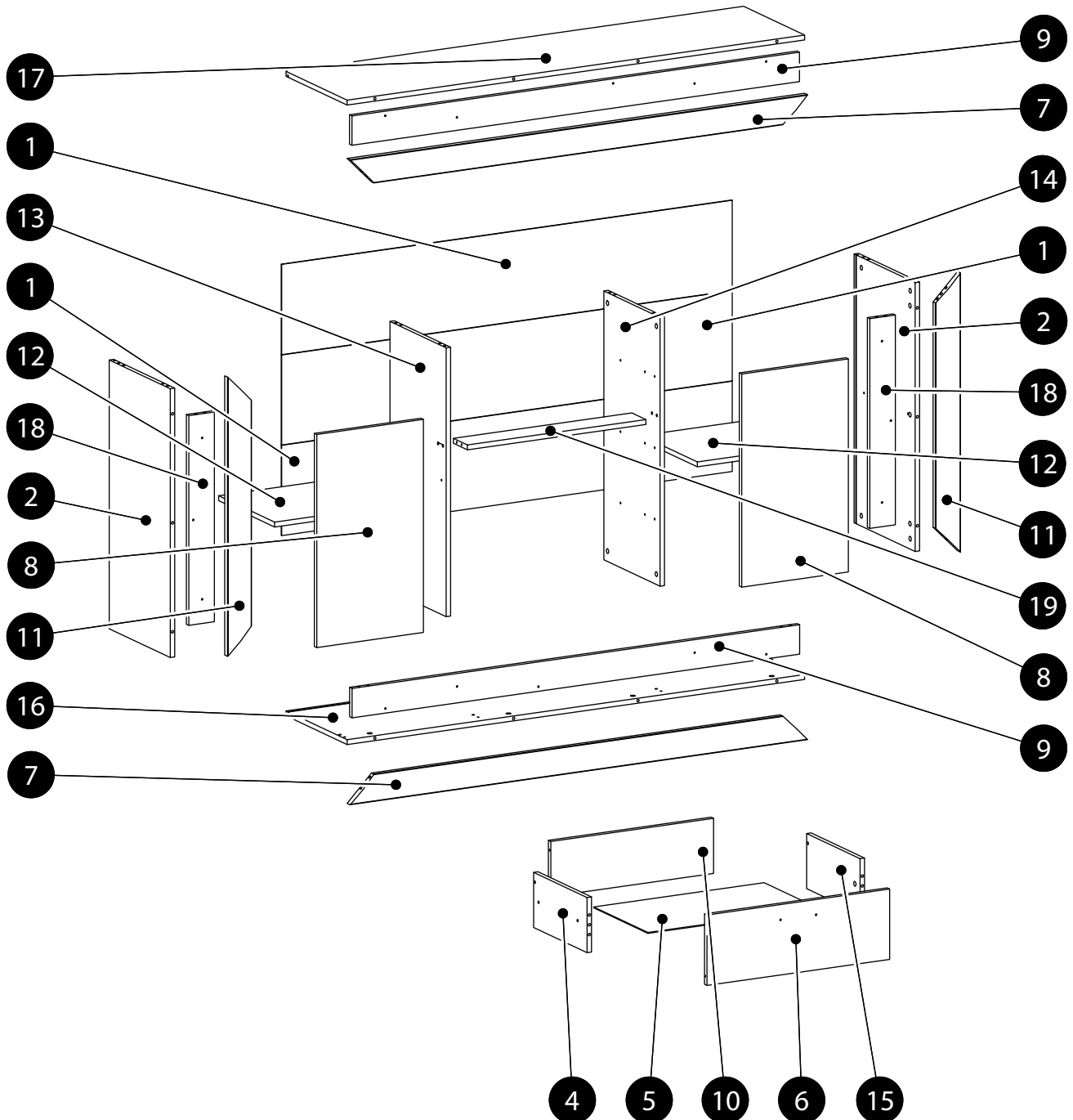

1.

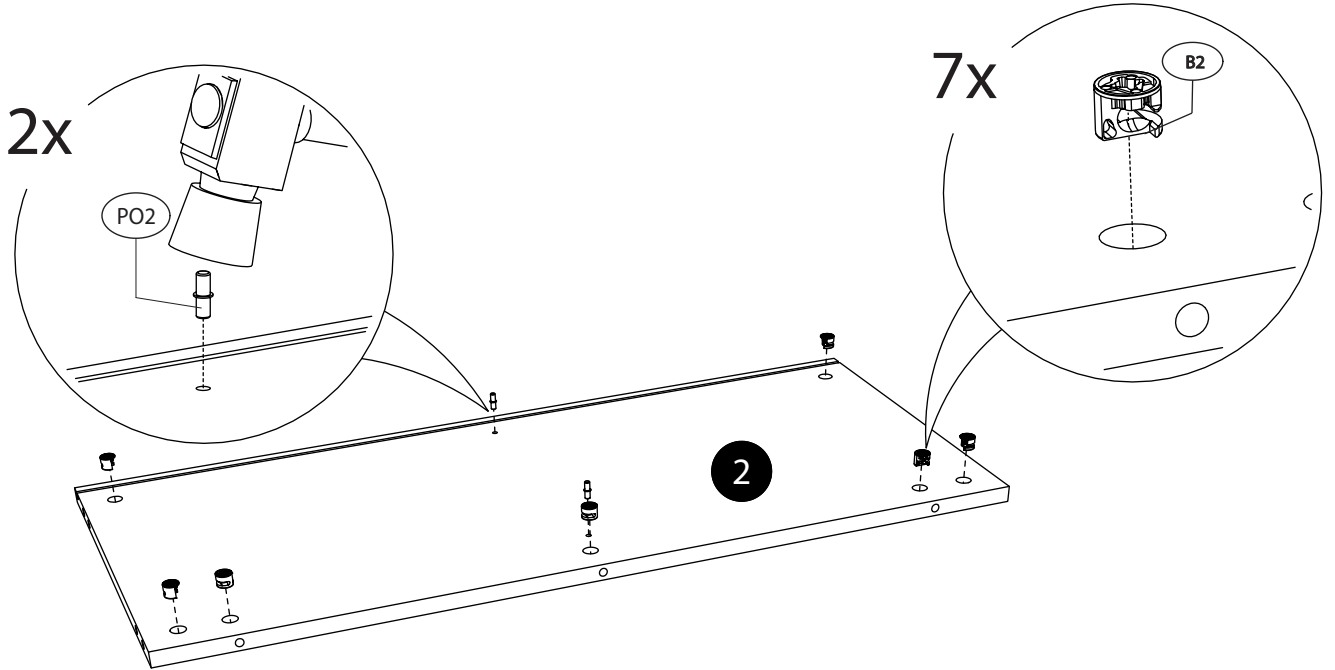
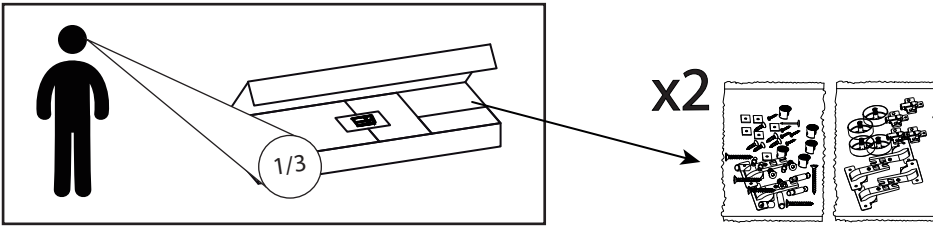

2.

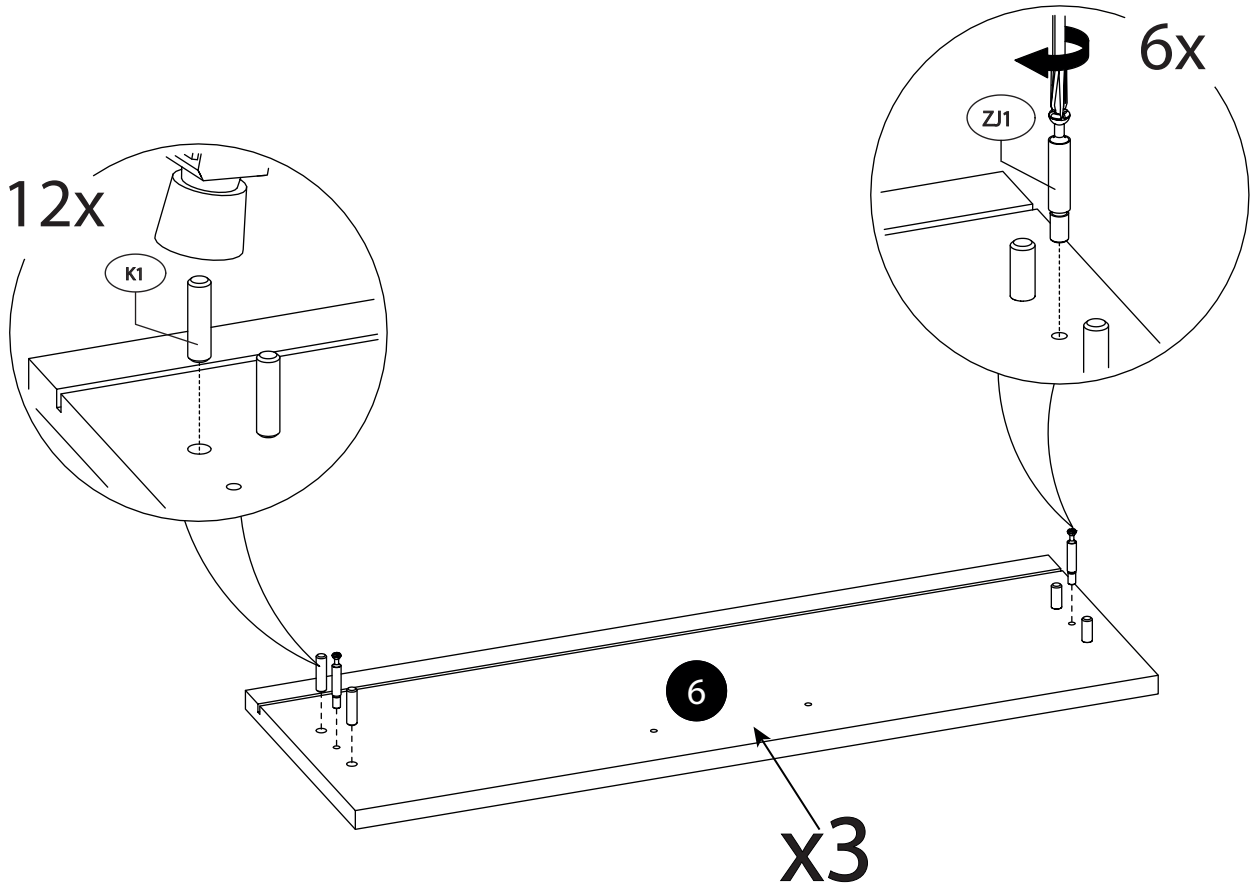

3.

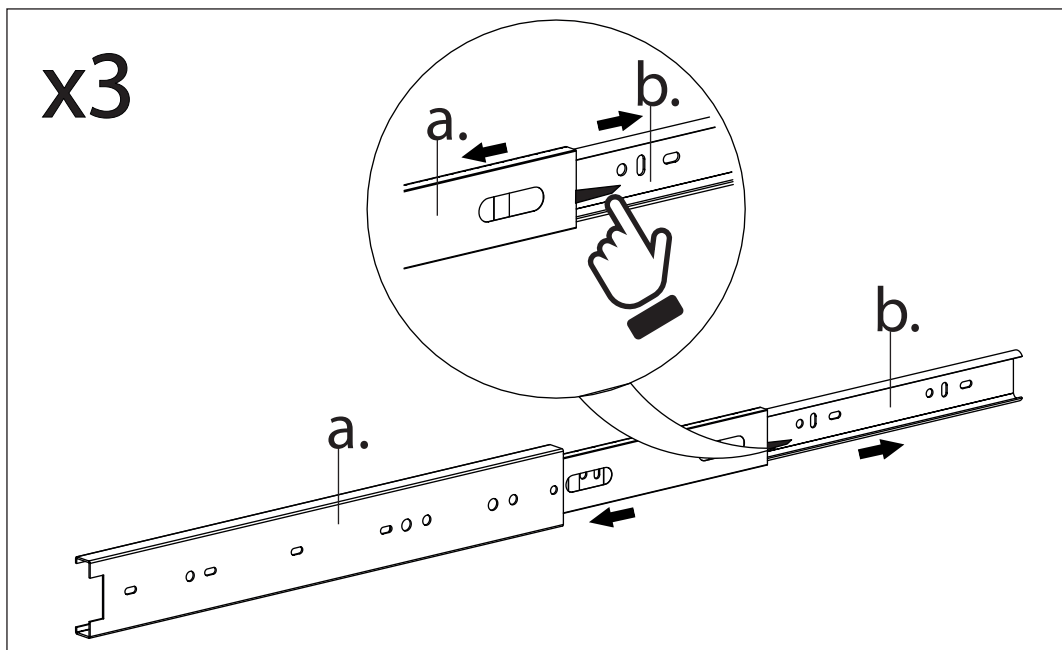

4.

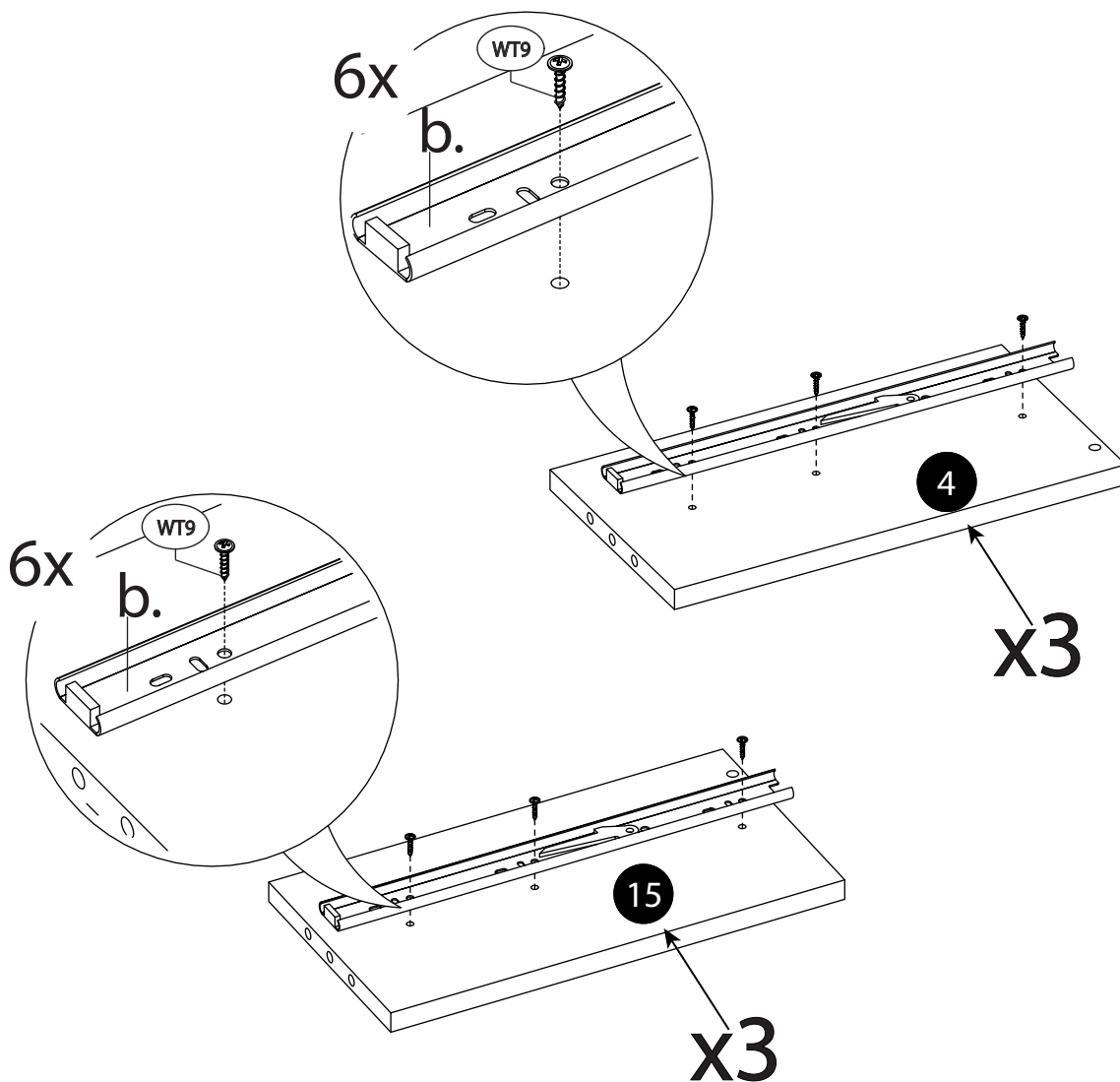

5.

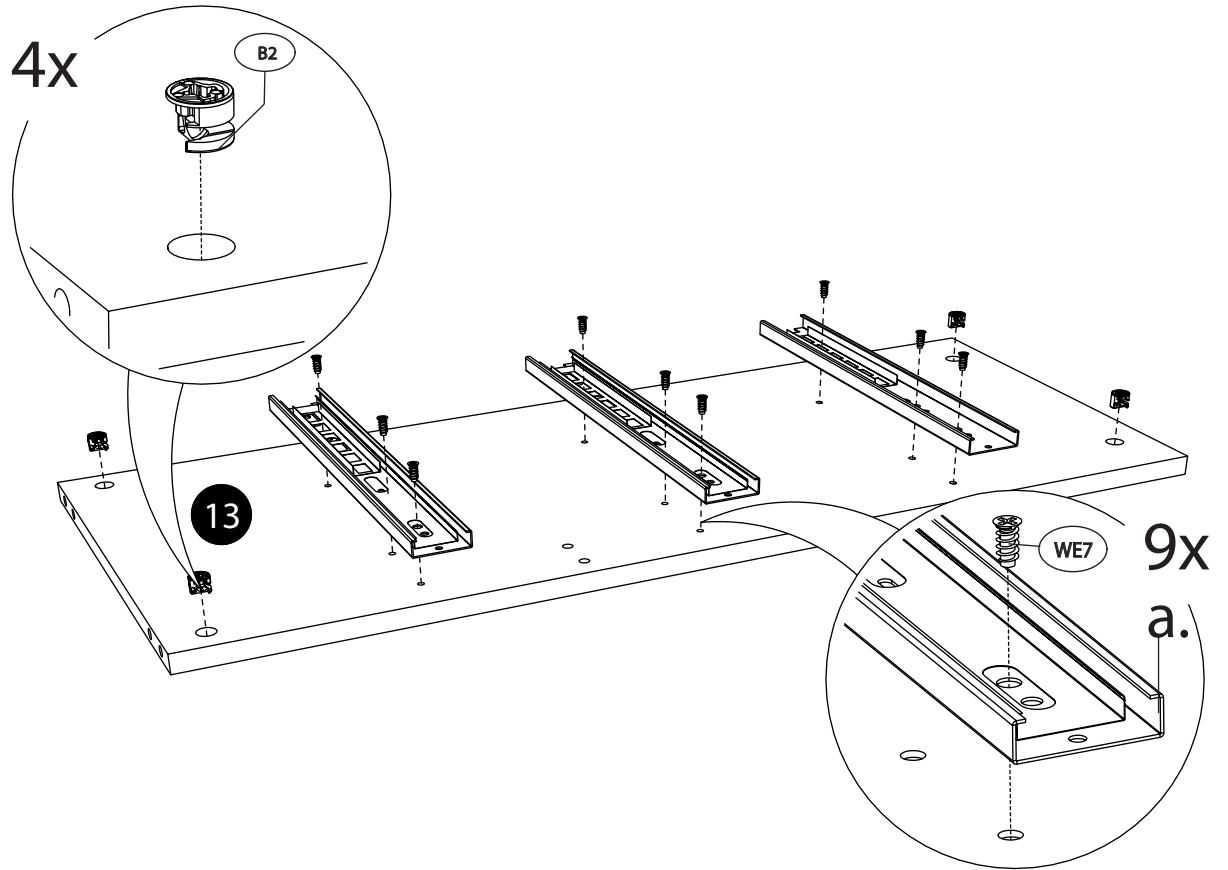

6.

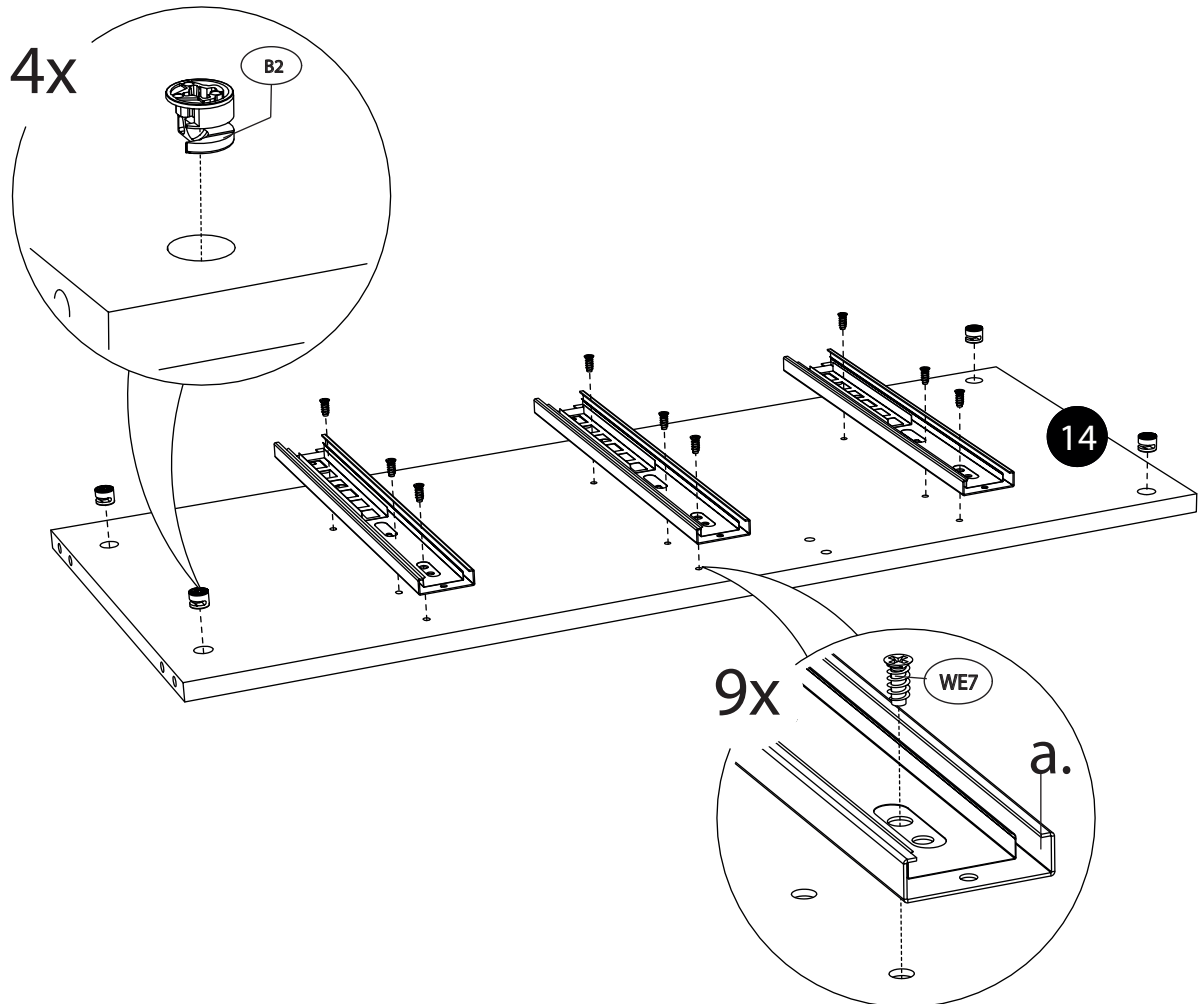

7.

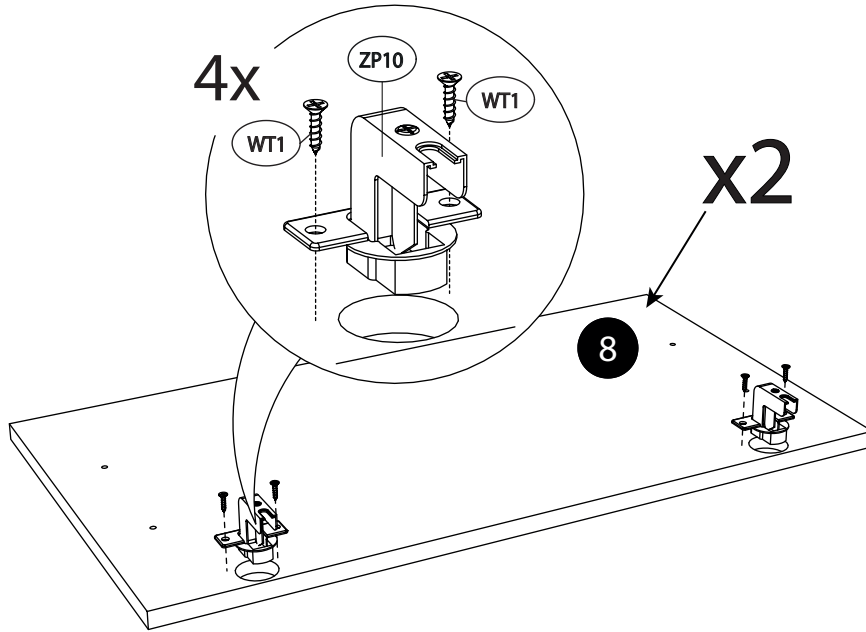

8.

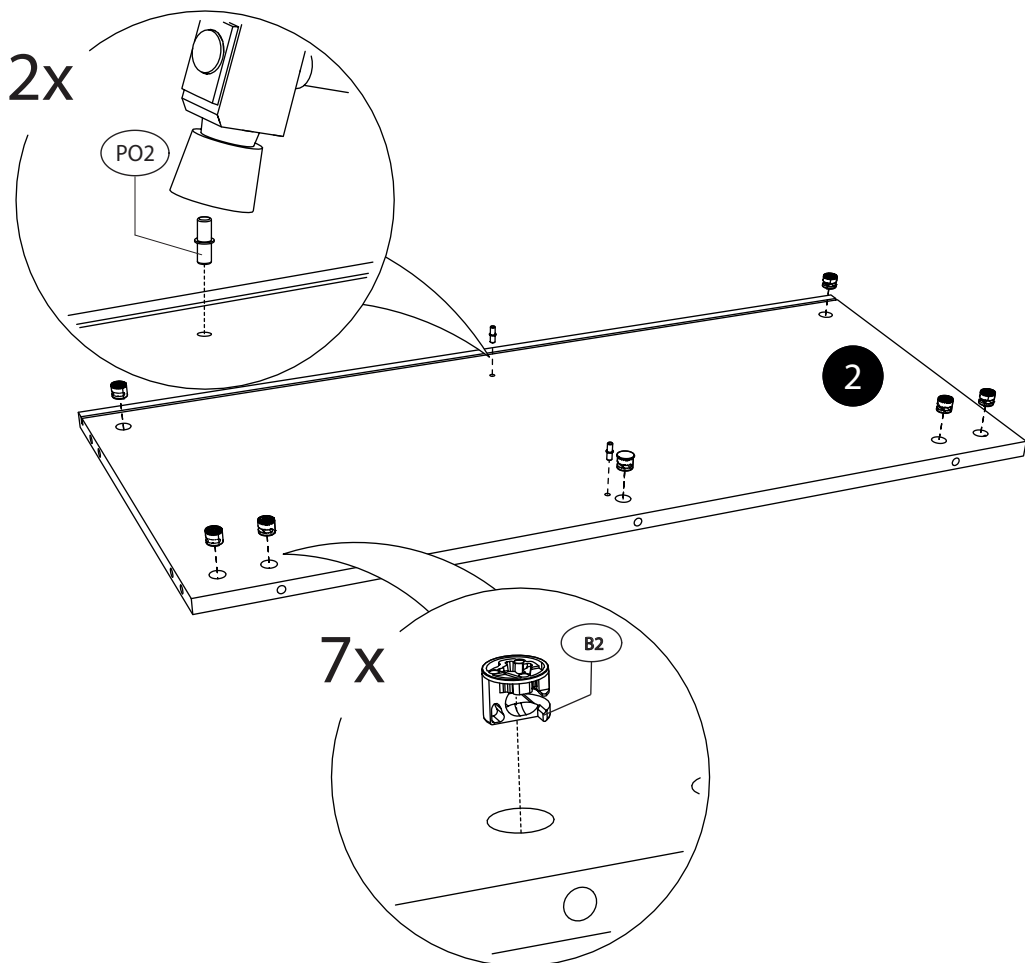



8.

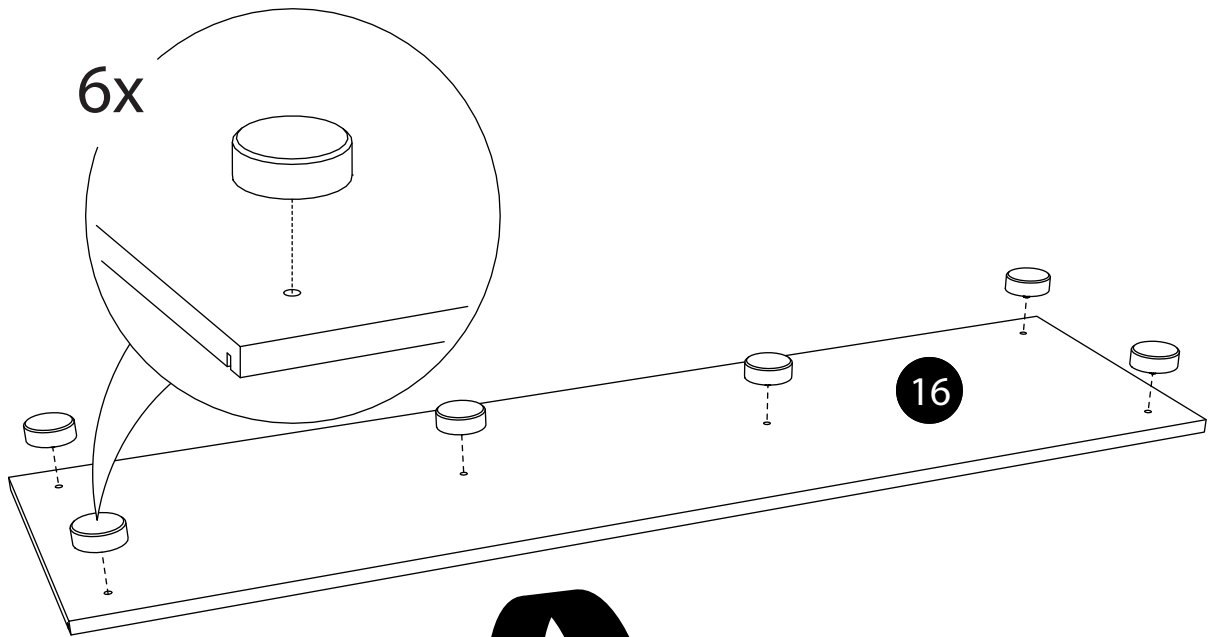
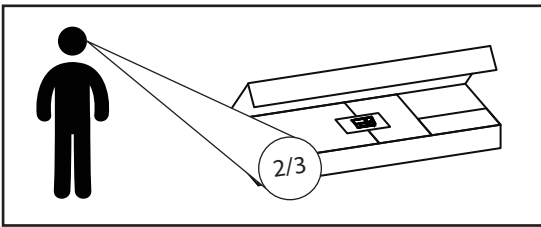

9.

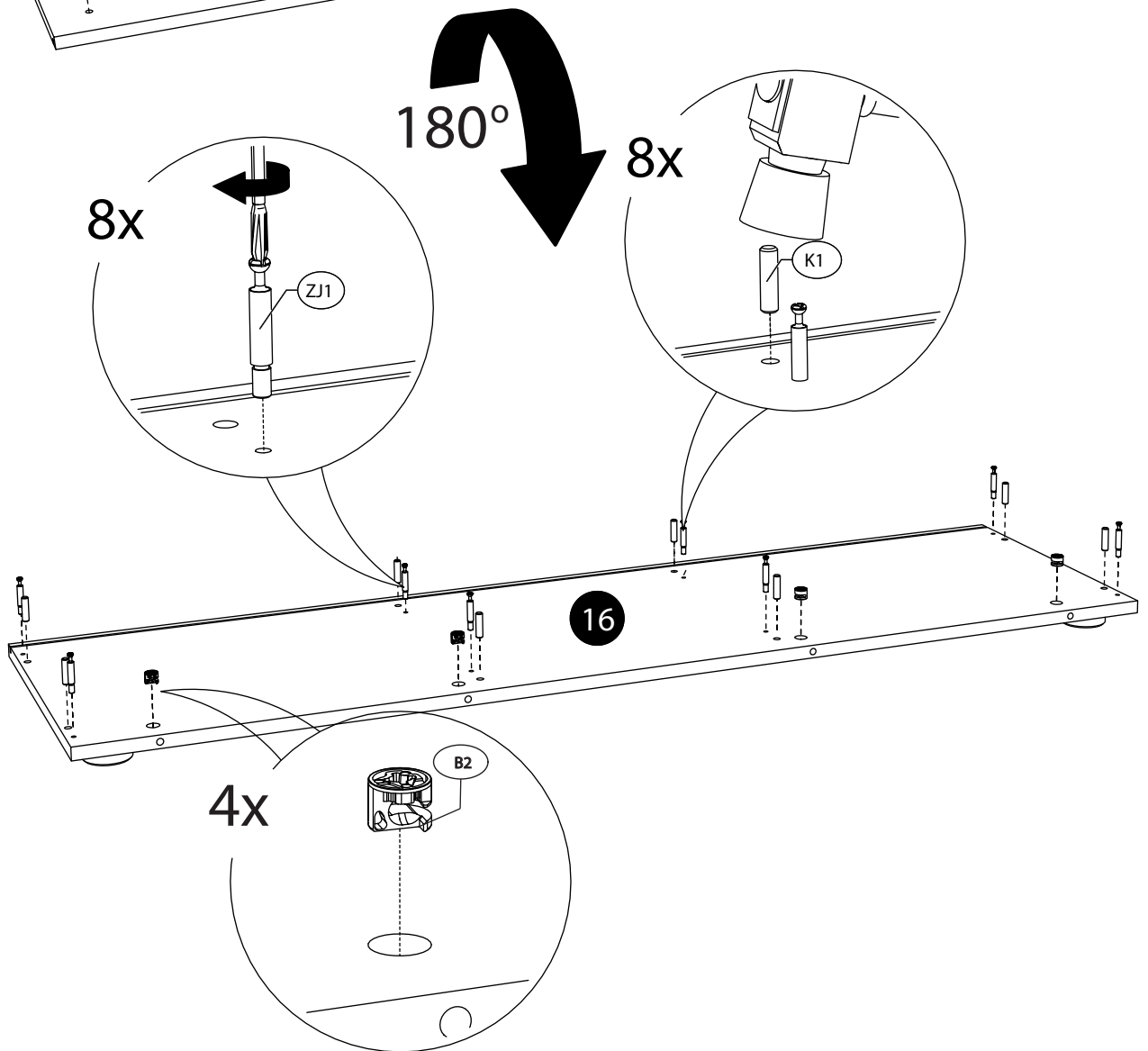

10.

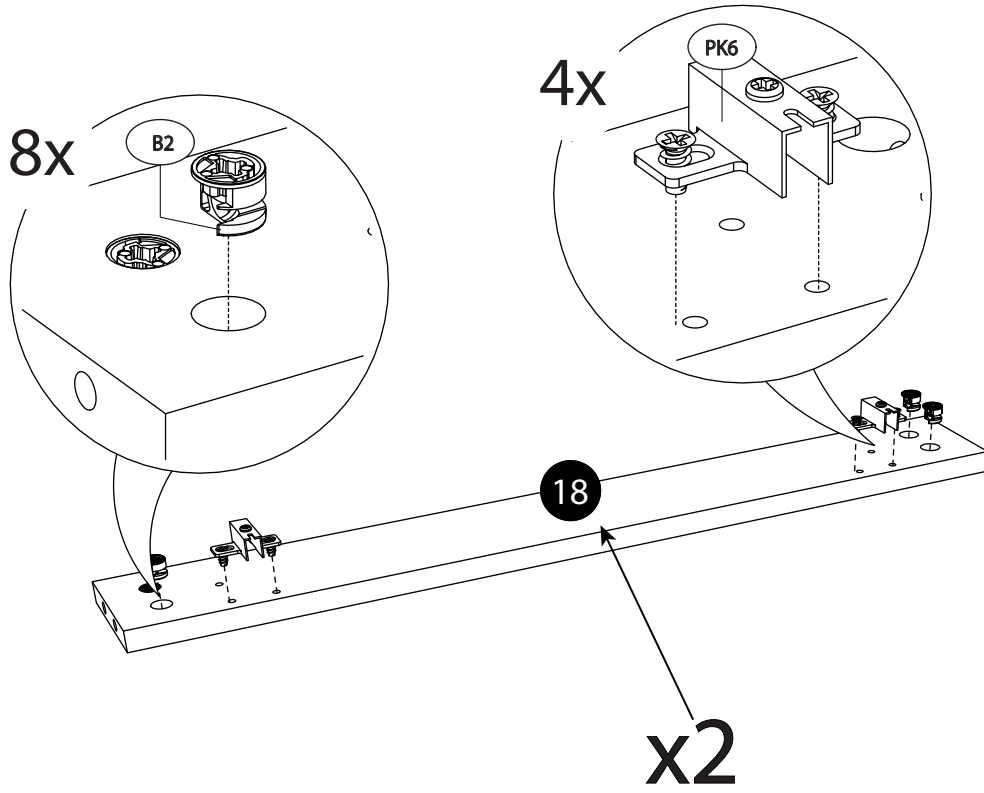

11.

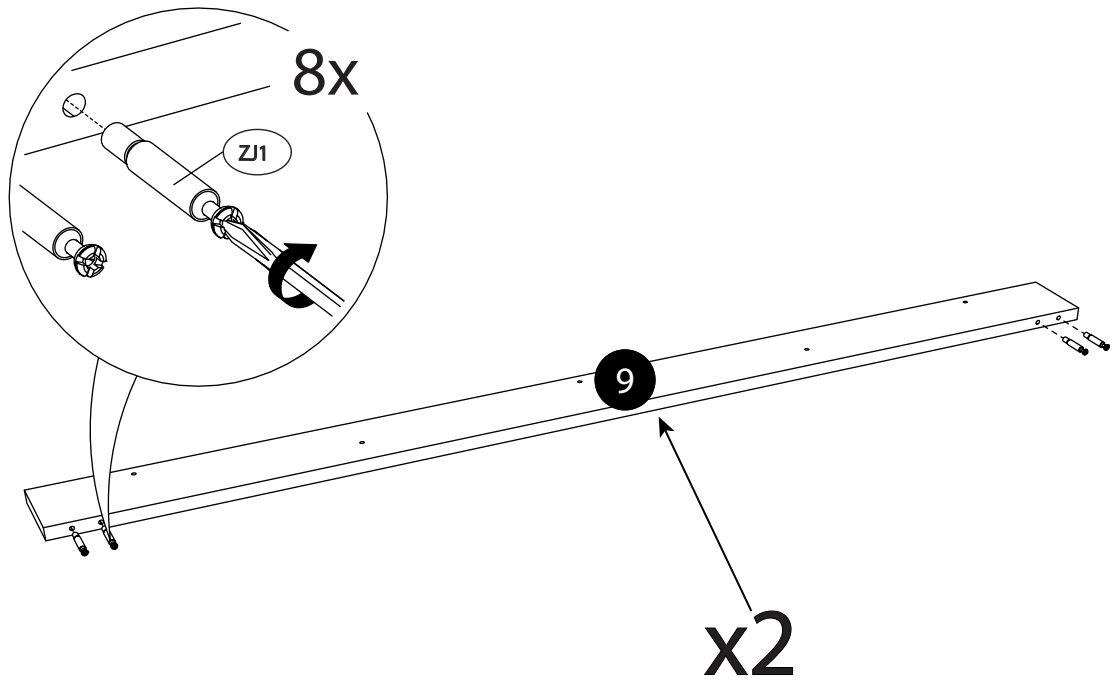

12.

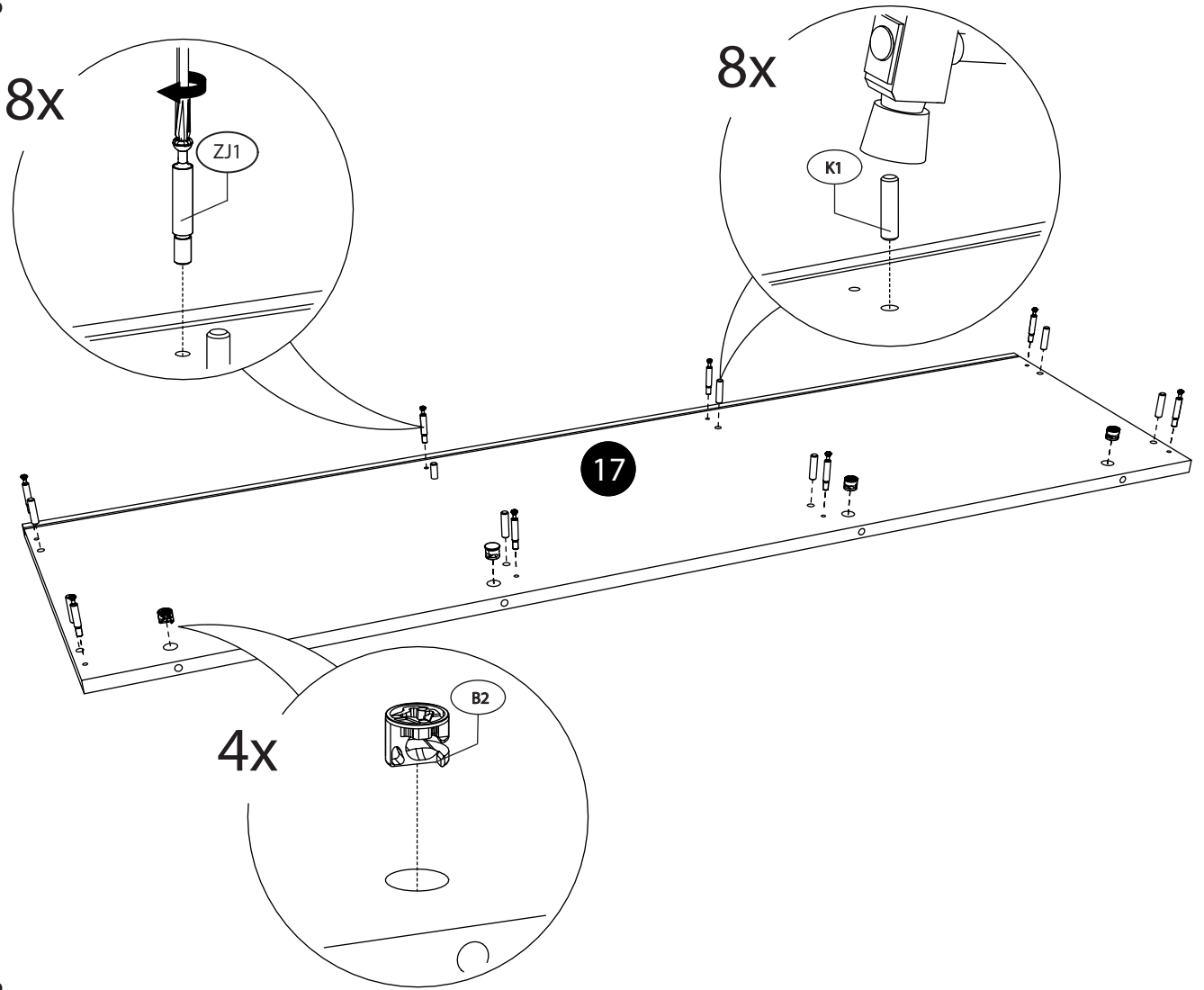

13.

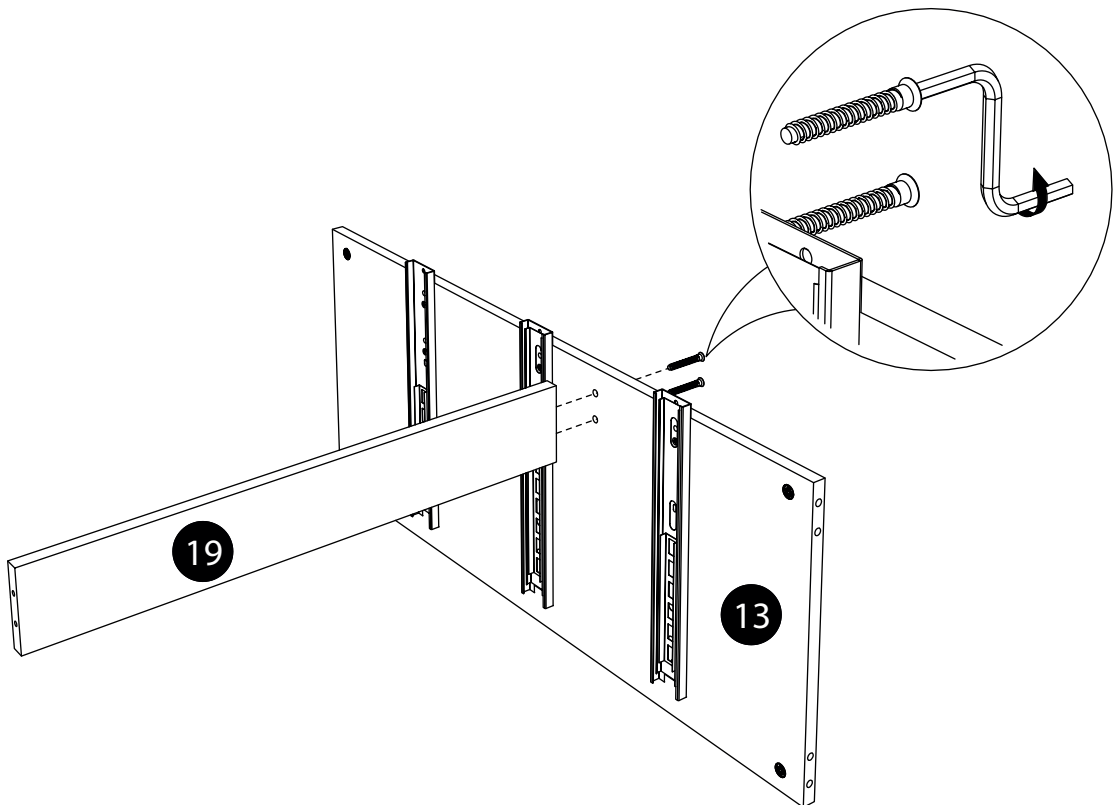

# 14.

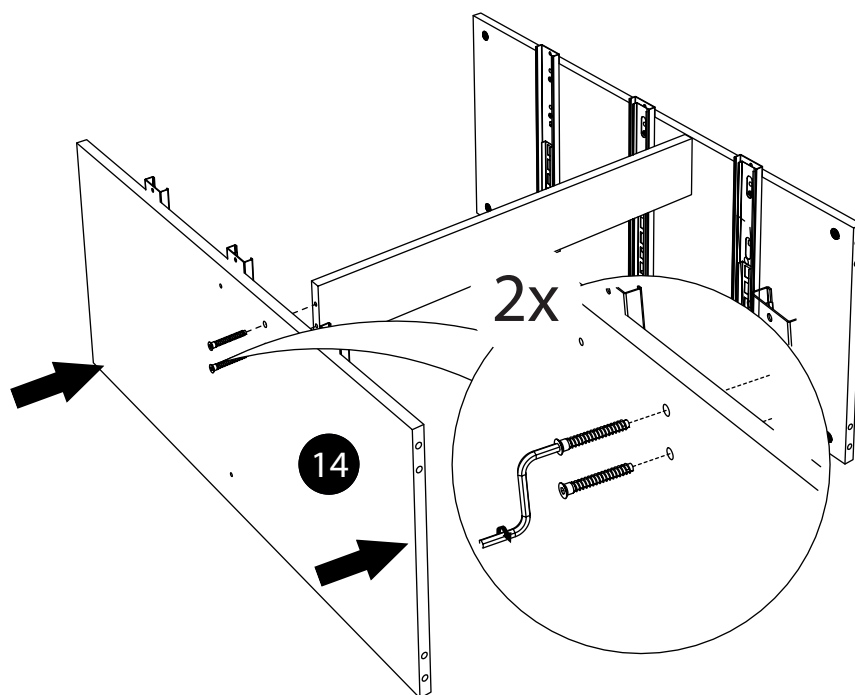

# 15.

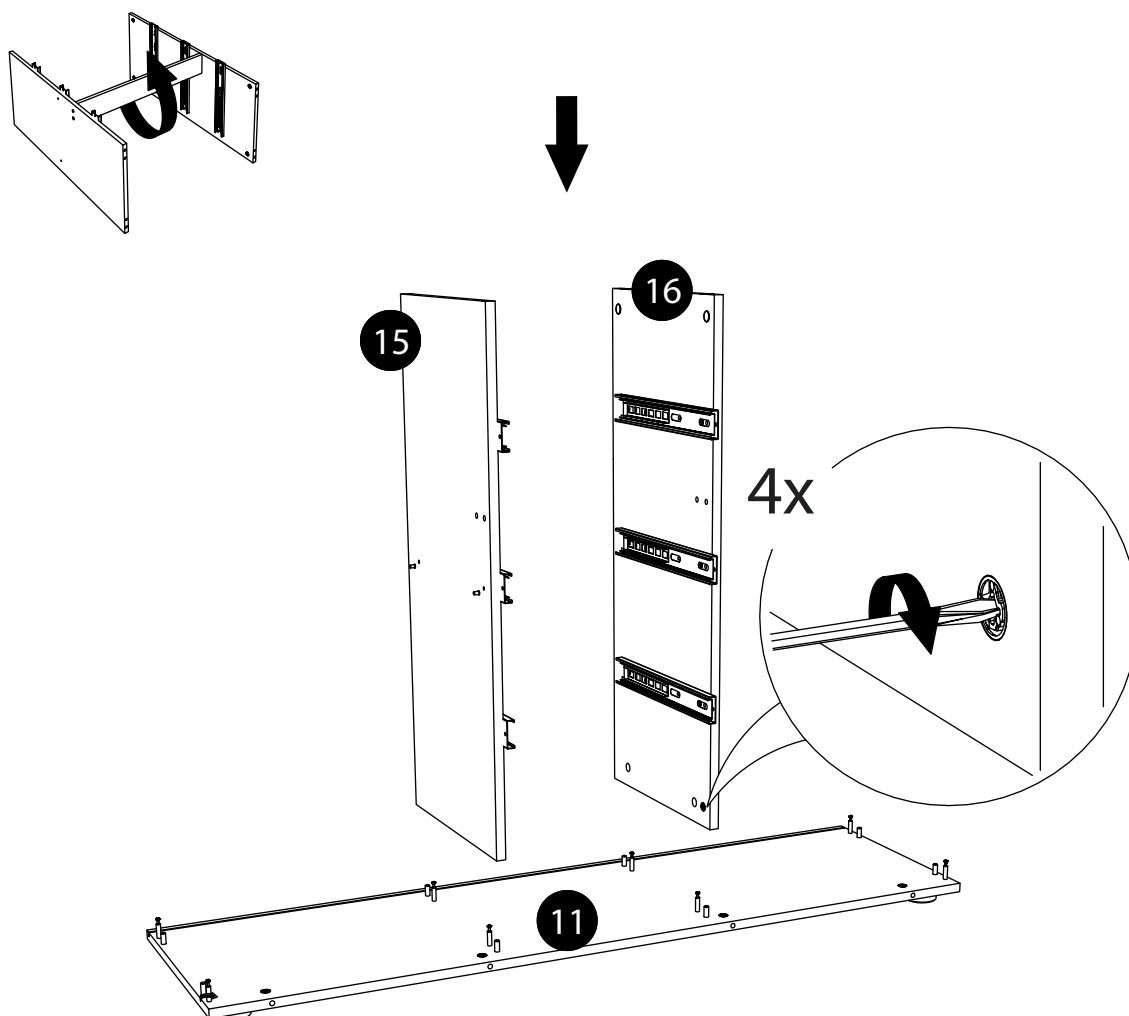

16.

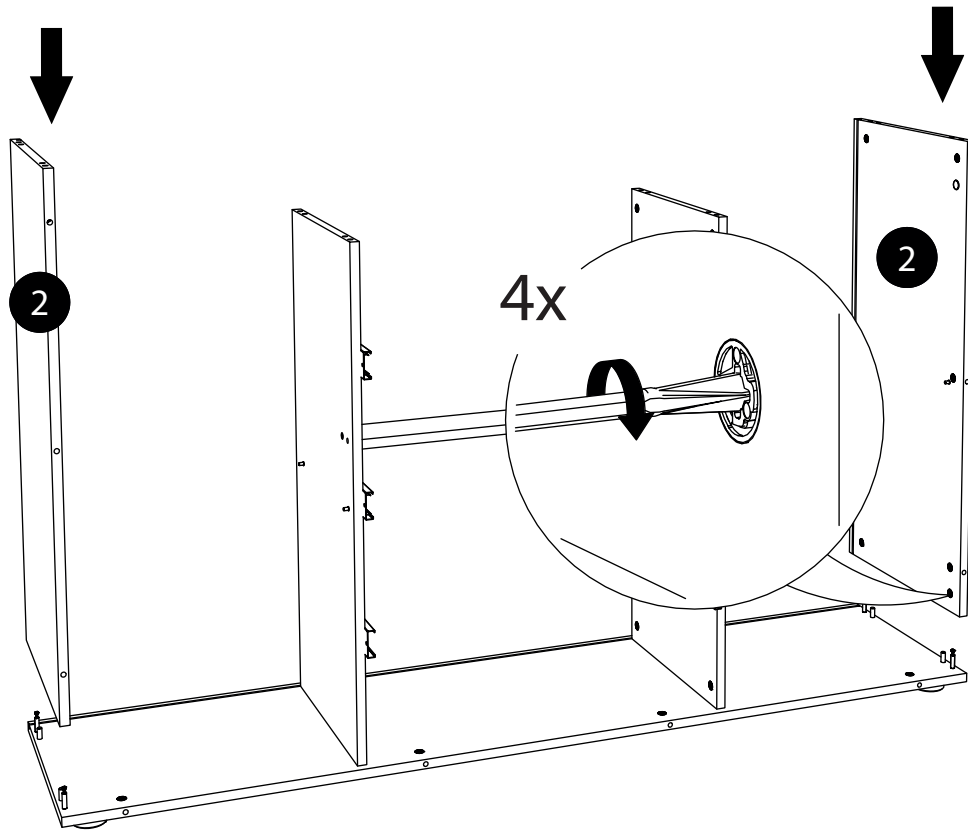

17.

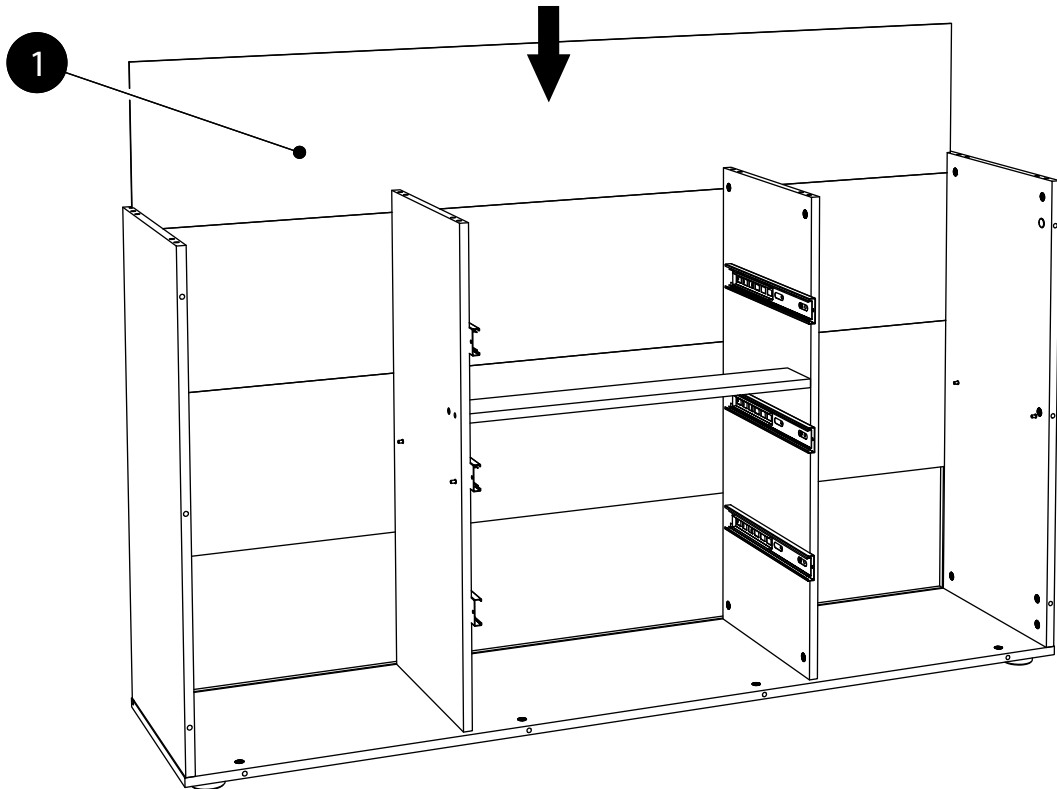

18.

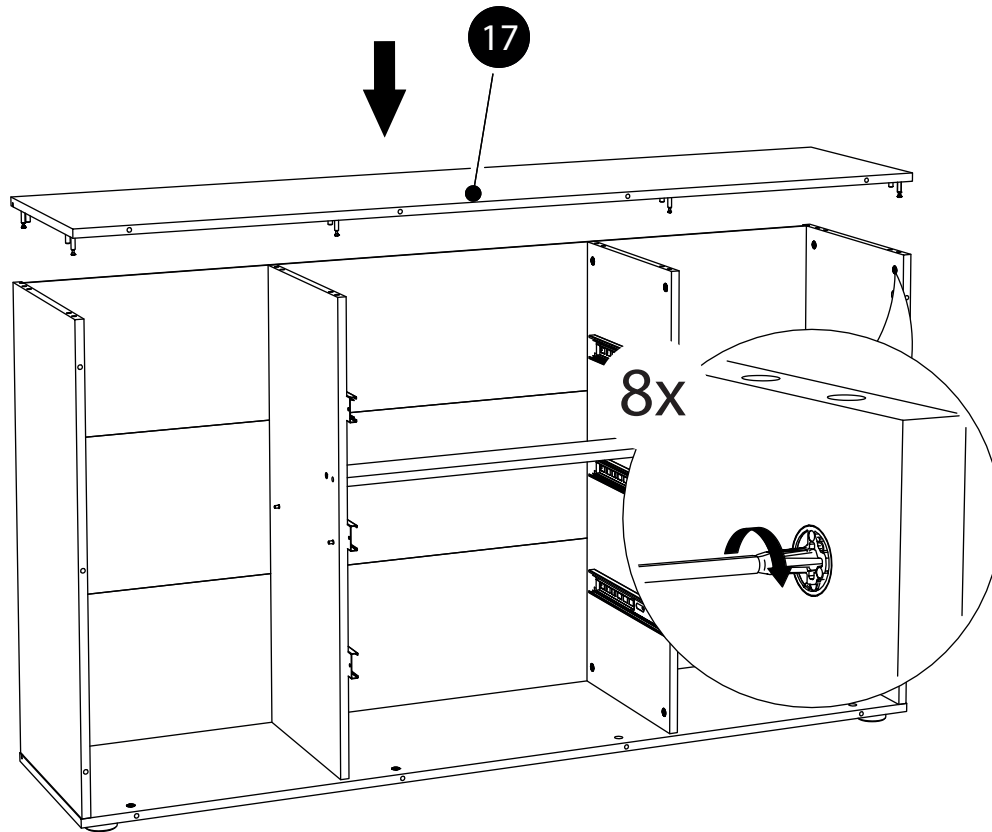

19.

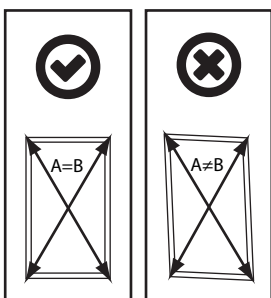
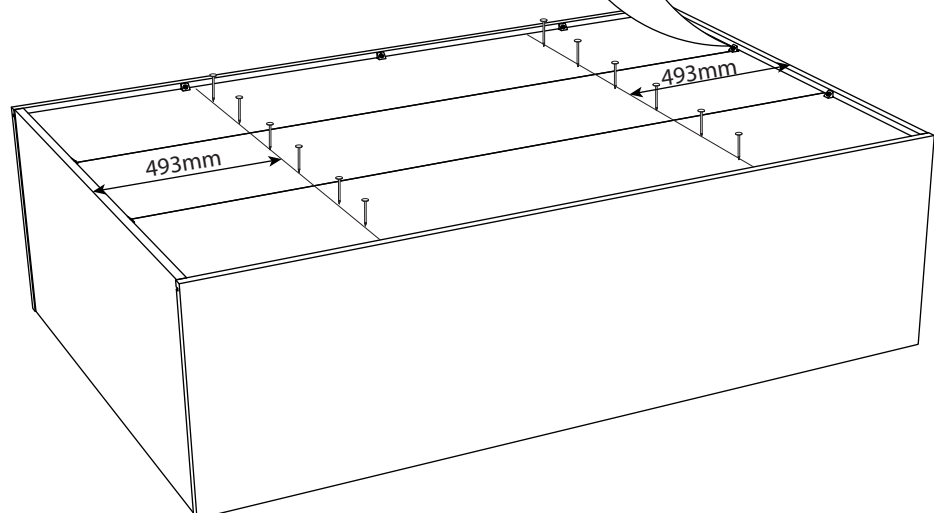
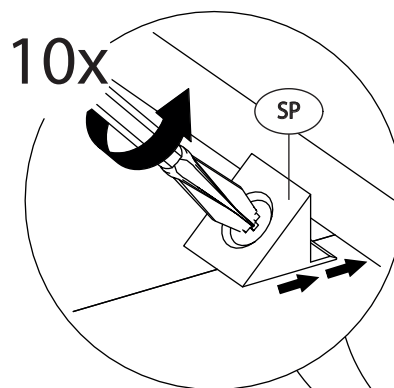
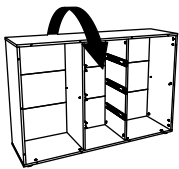

20.

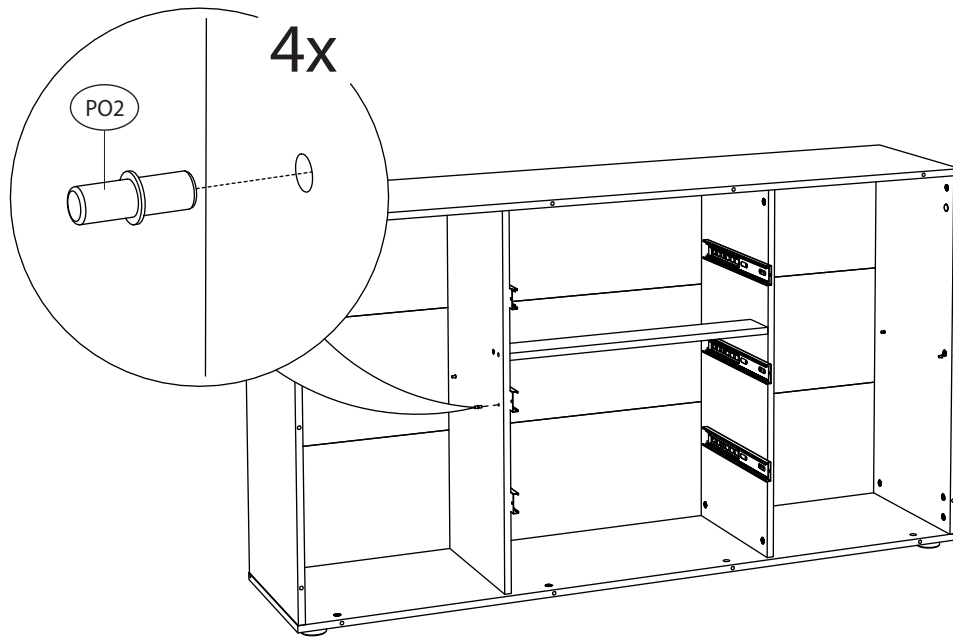
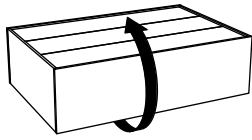

21.

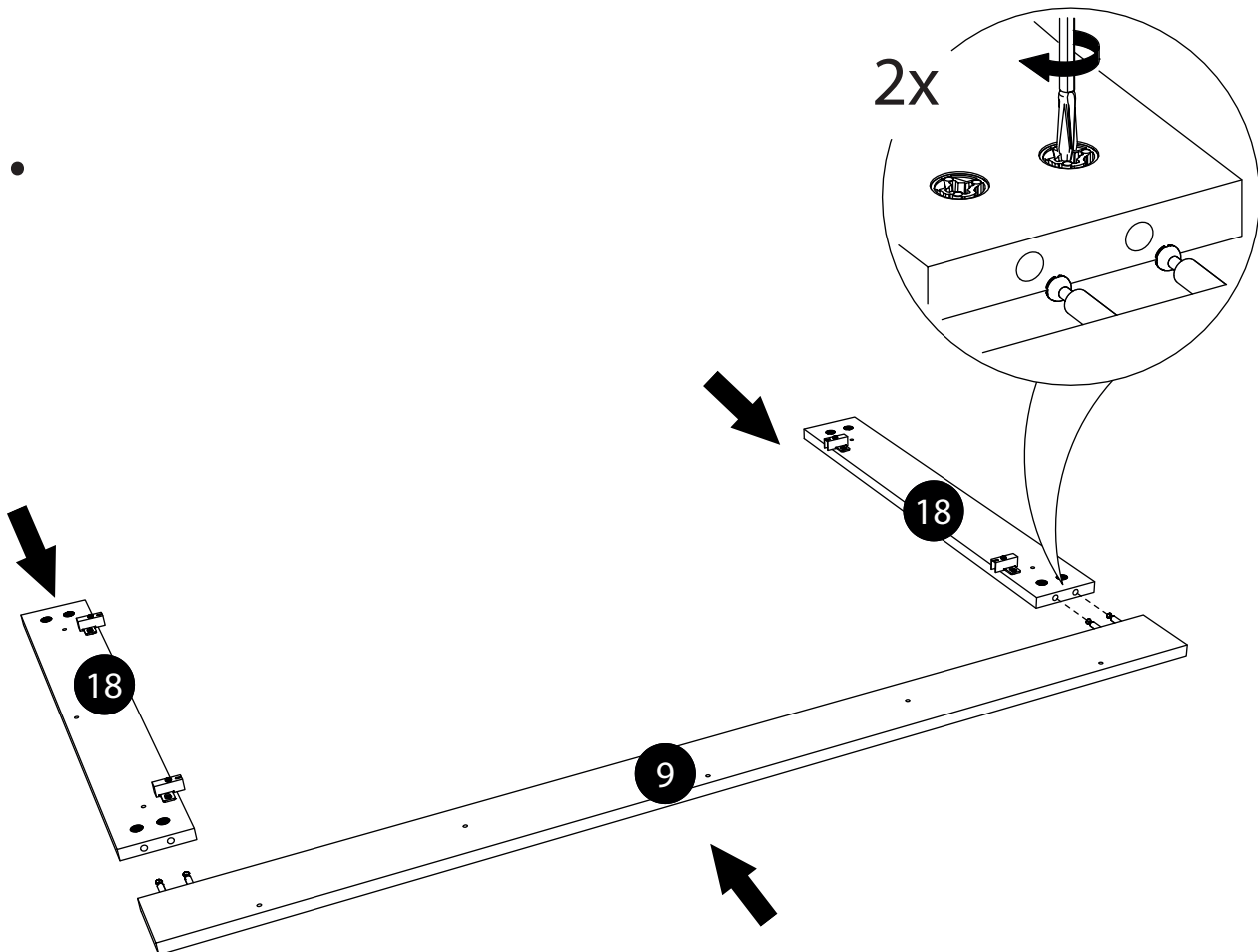

22.

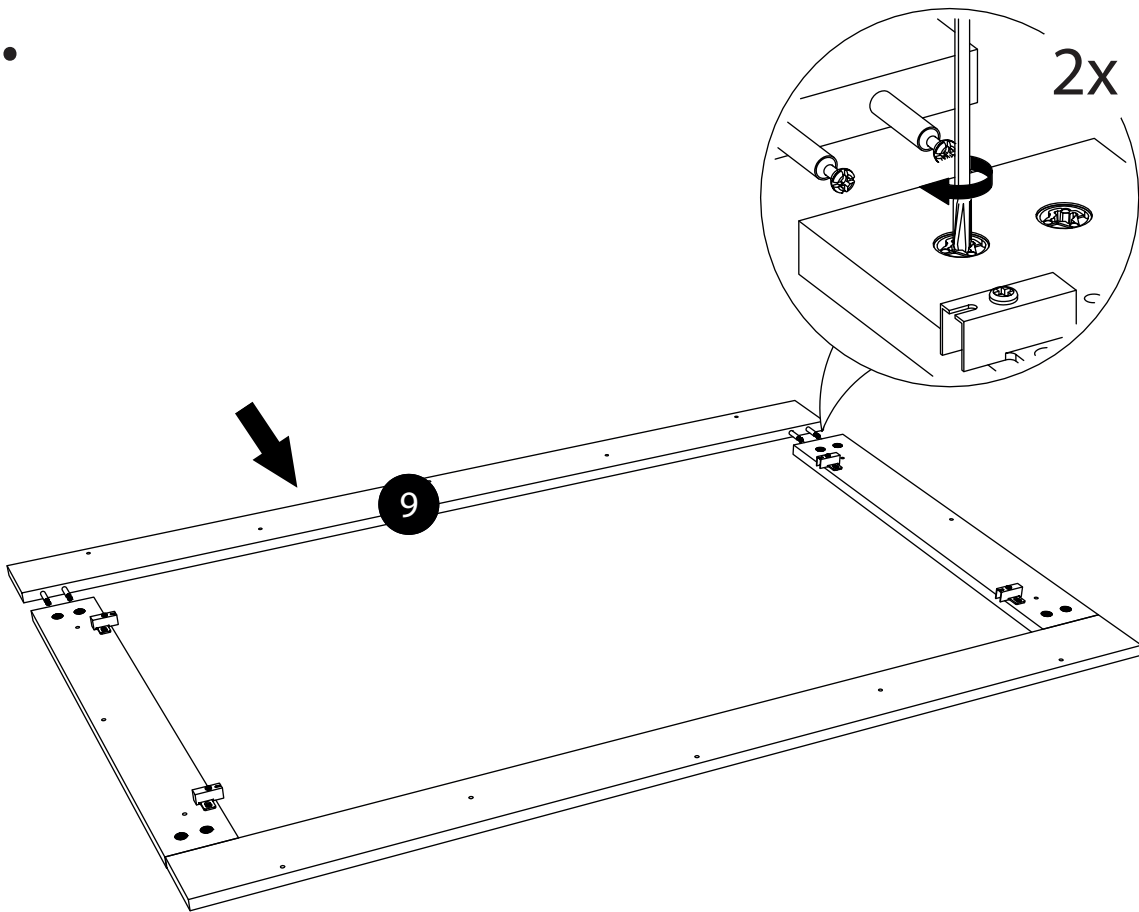

23.

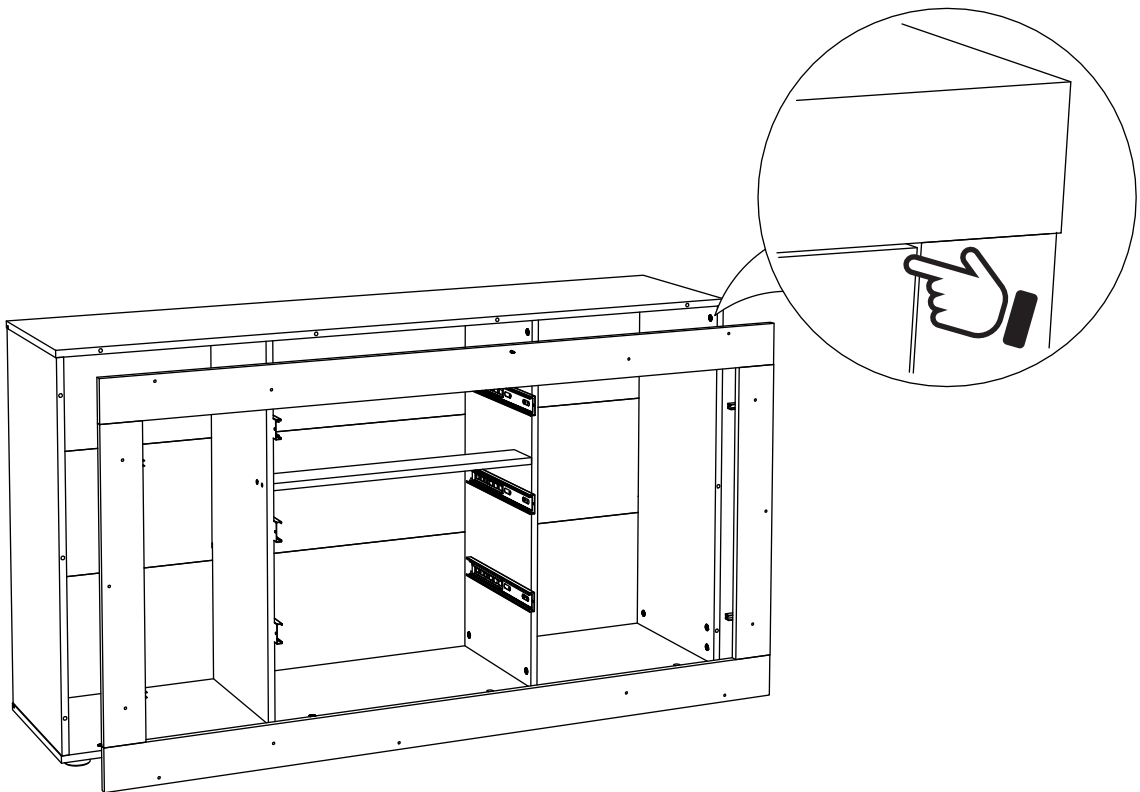



24.

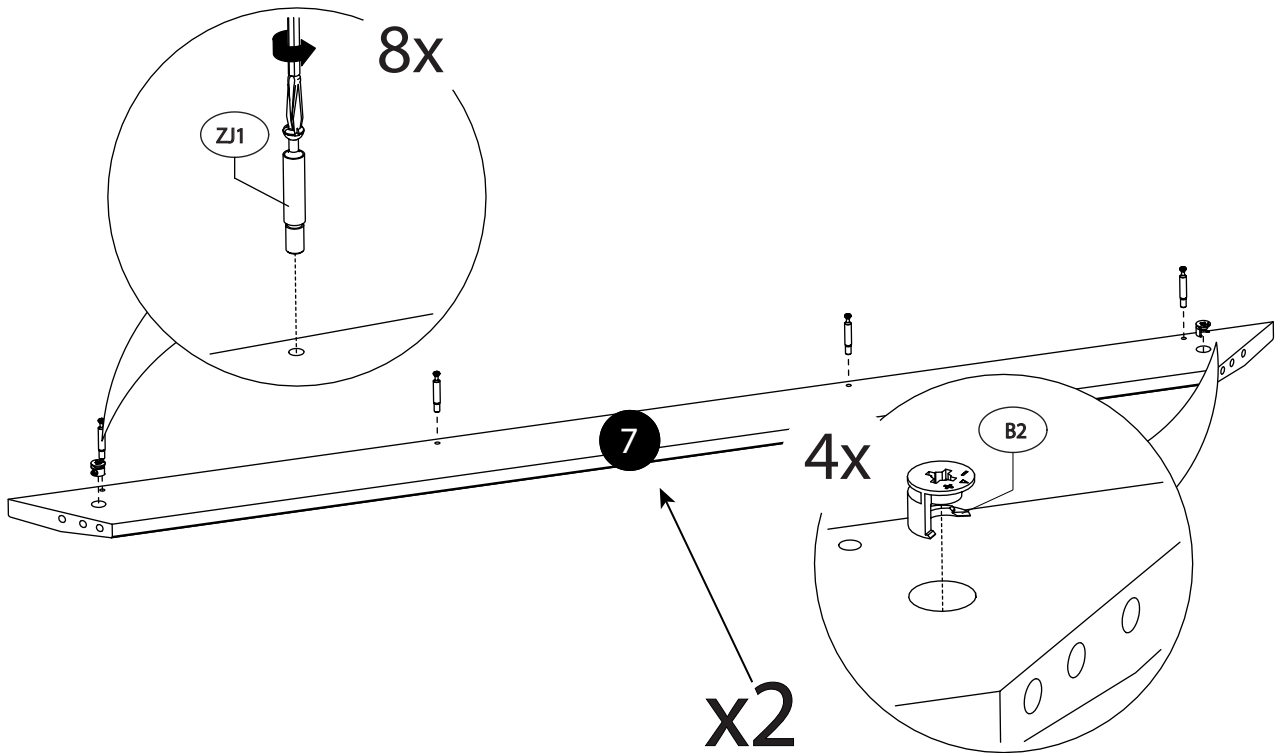
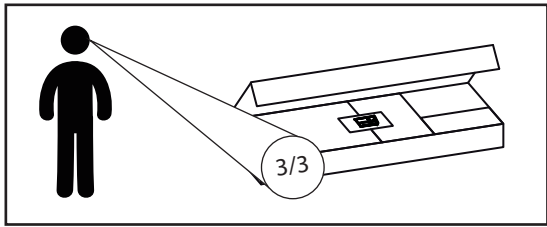

25.

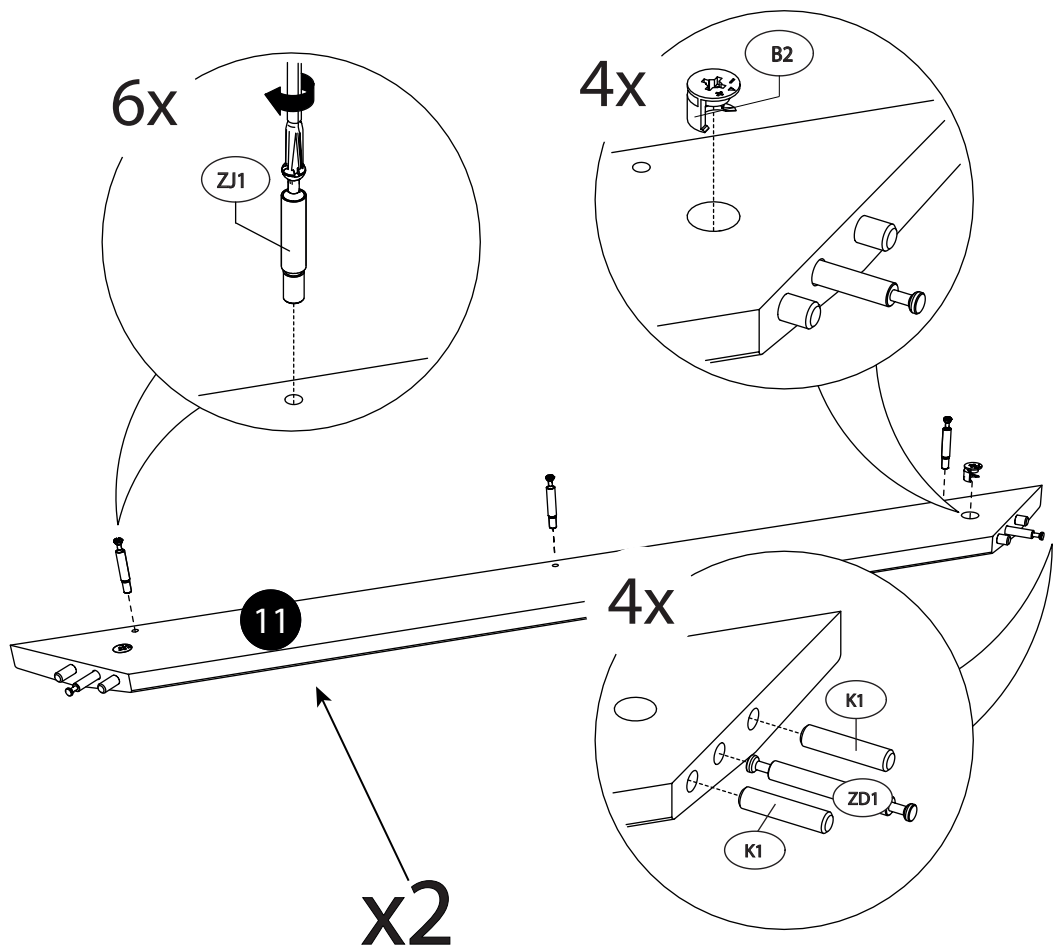

26.

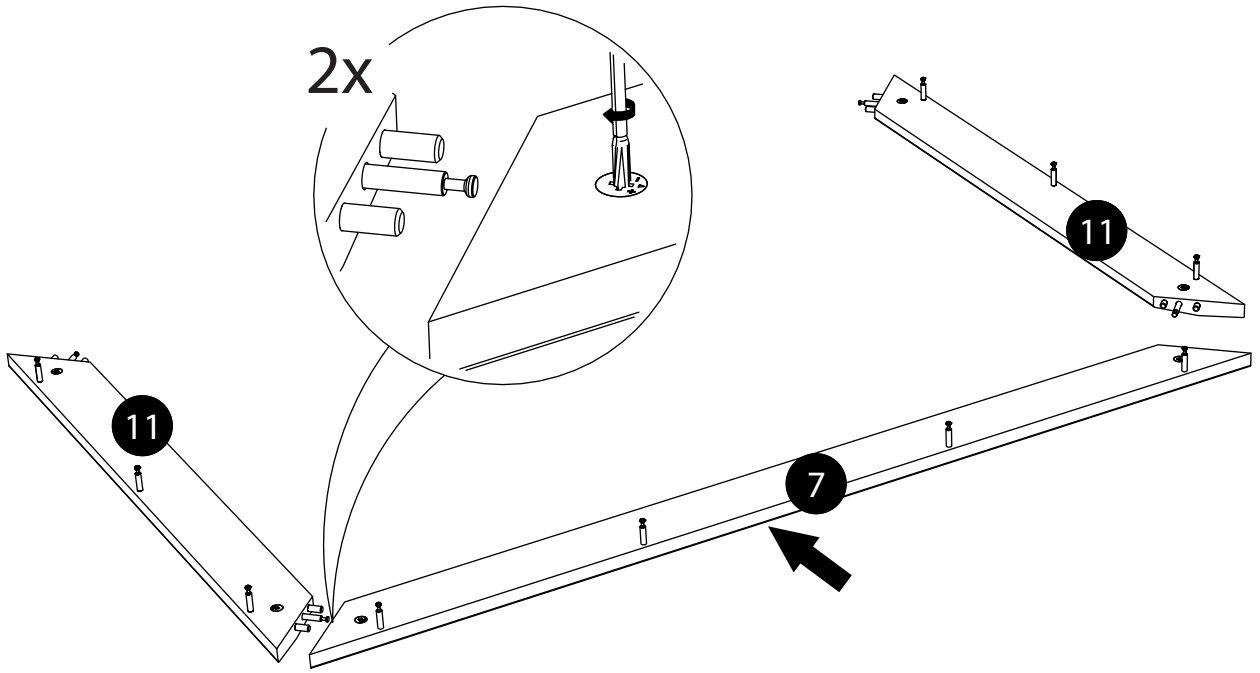

27.

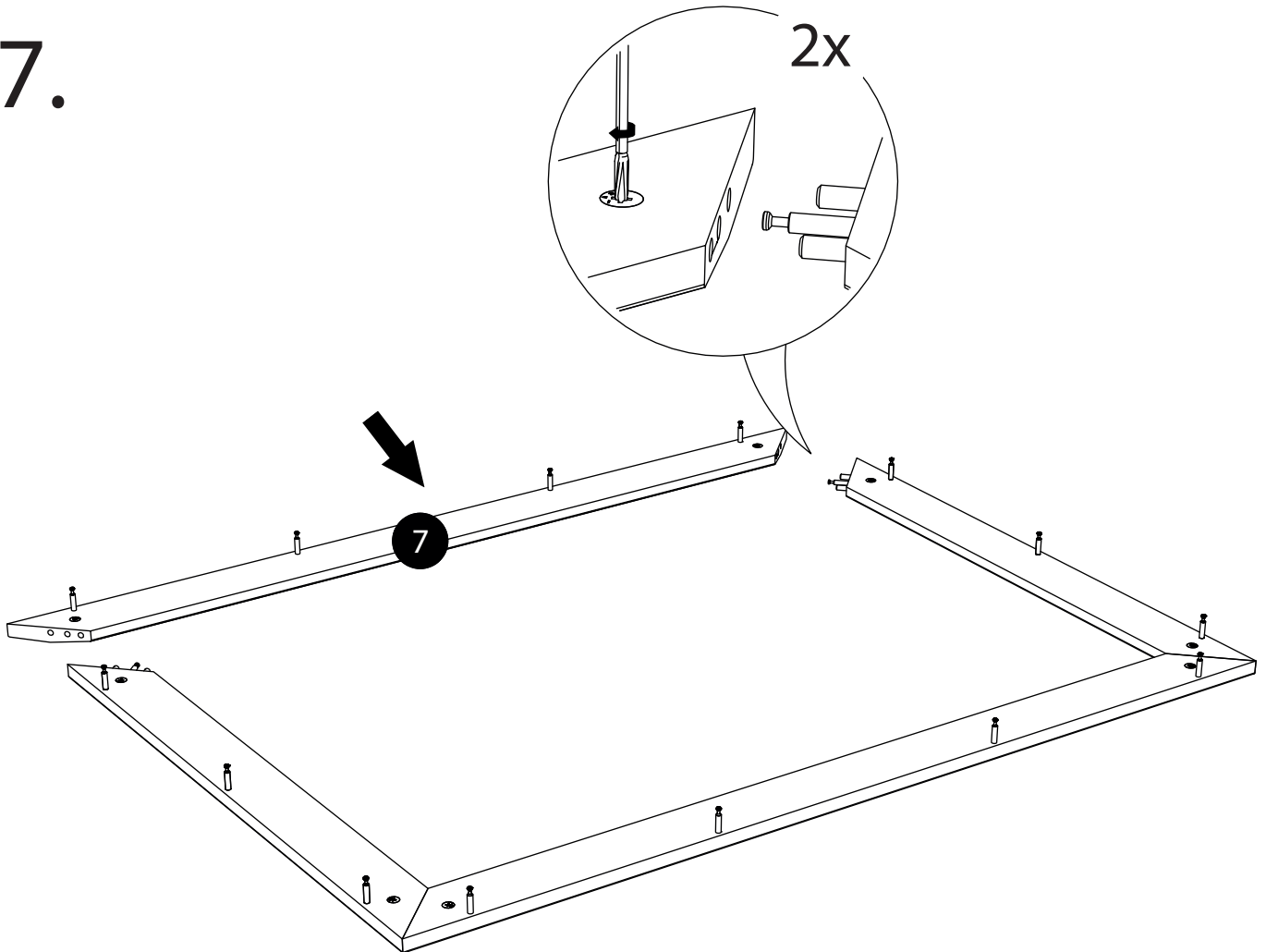

28.

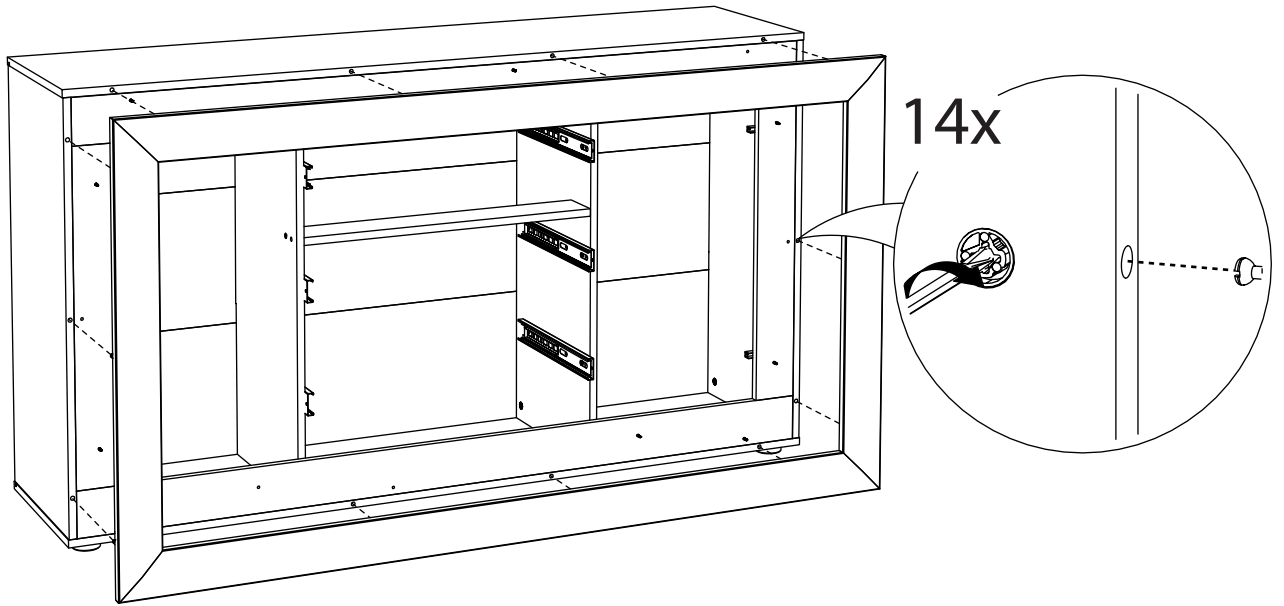

29.

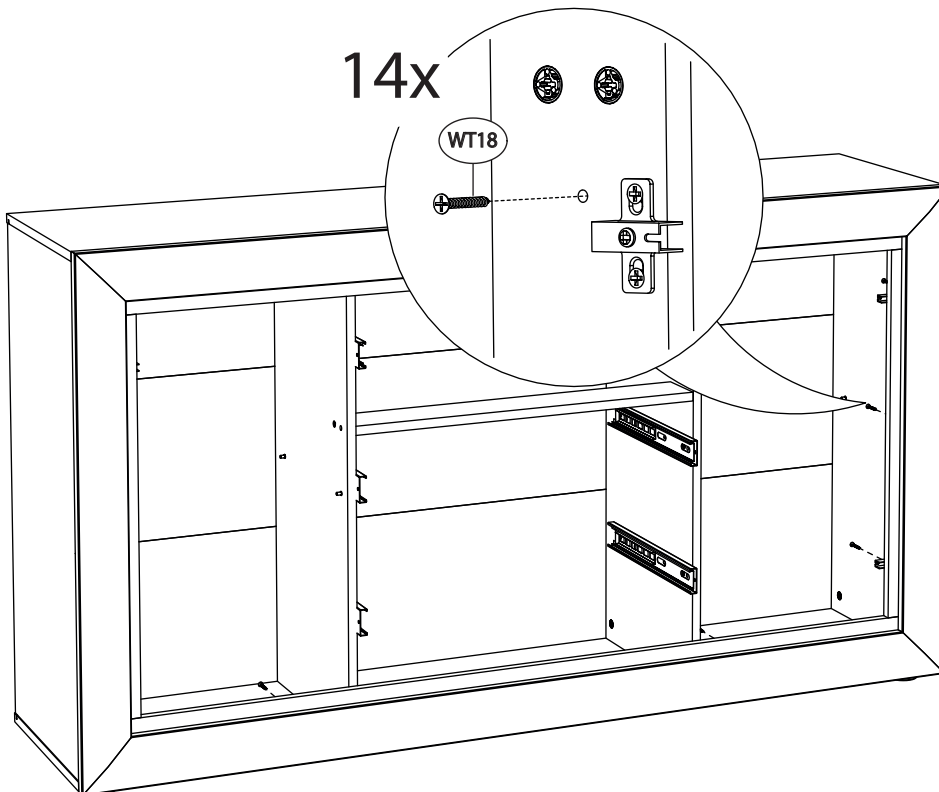

# 30.

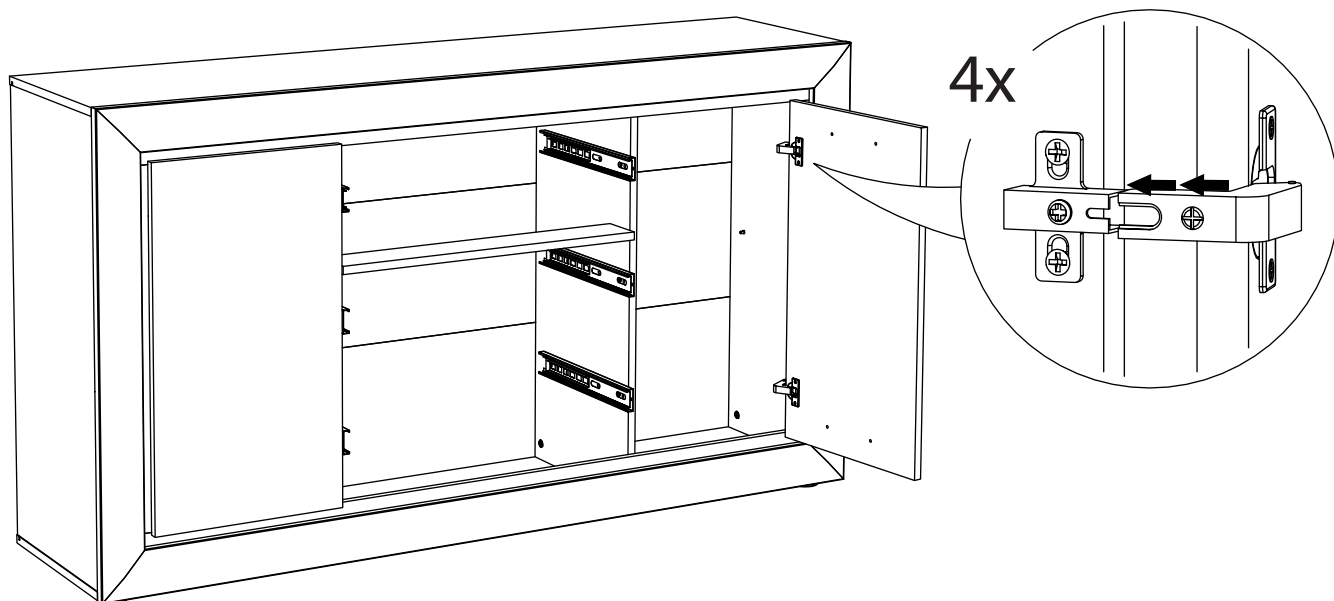
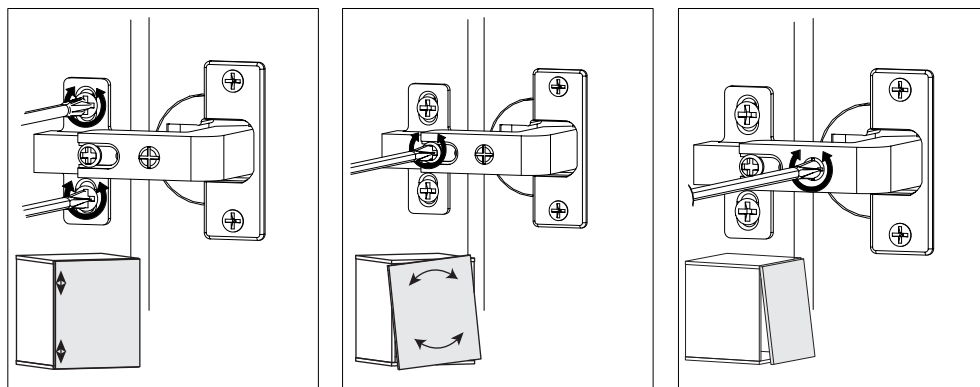

# 31.

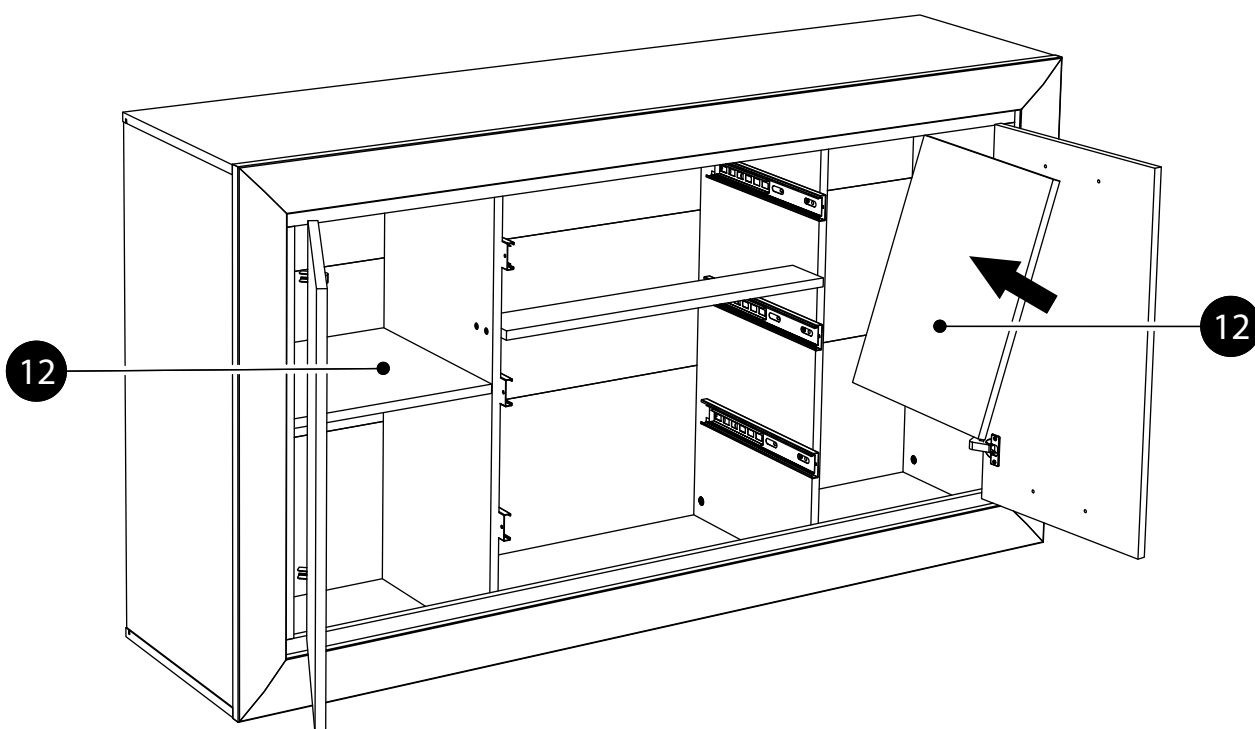

32.

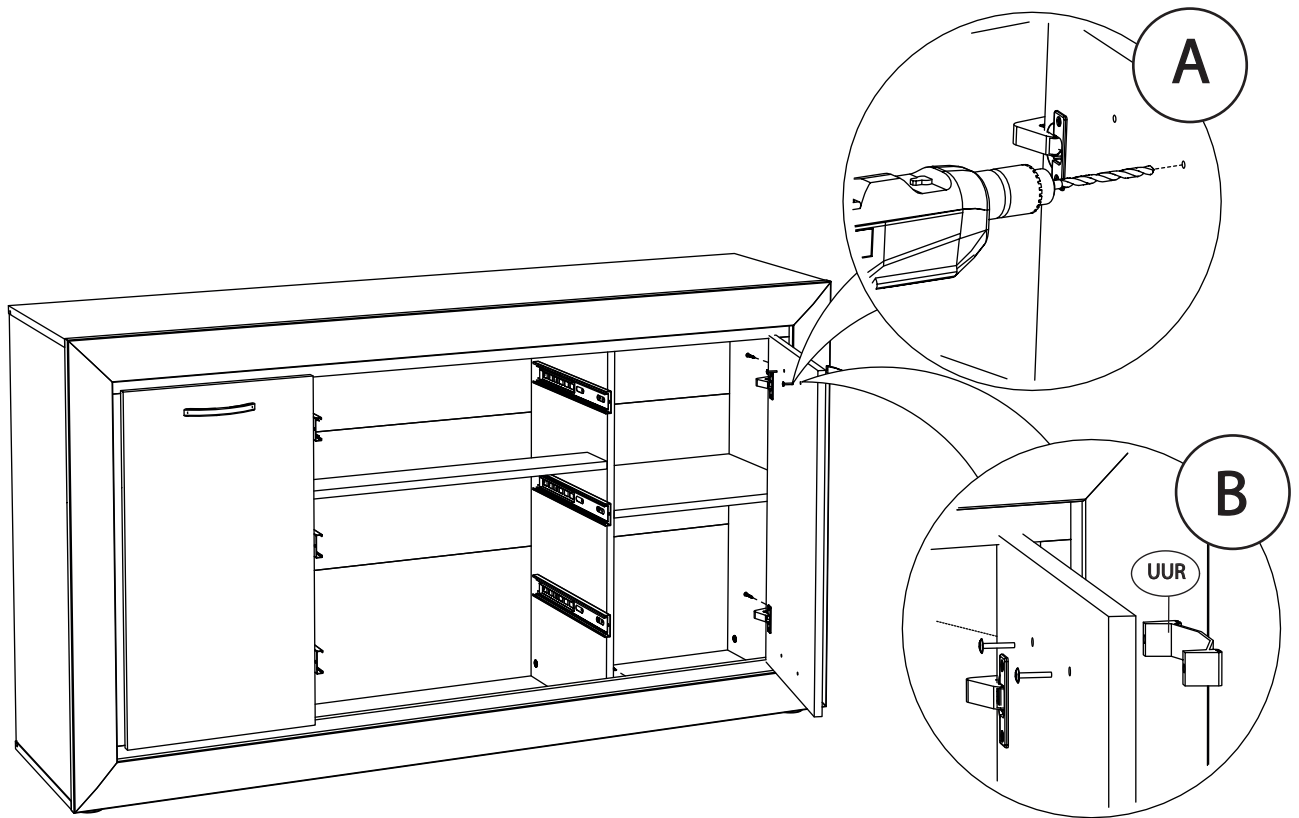

33.

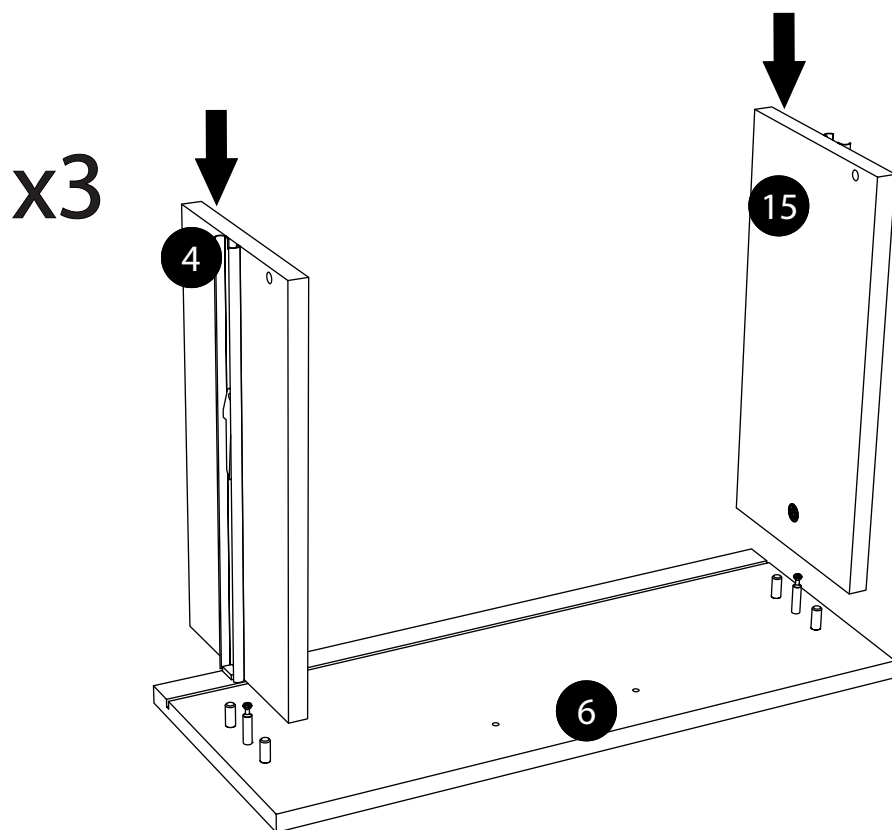

34.

x3

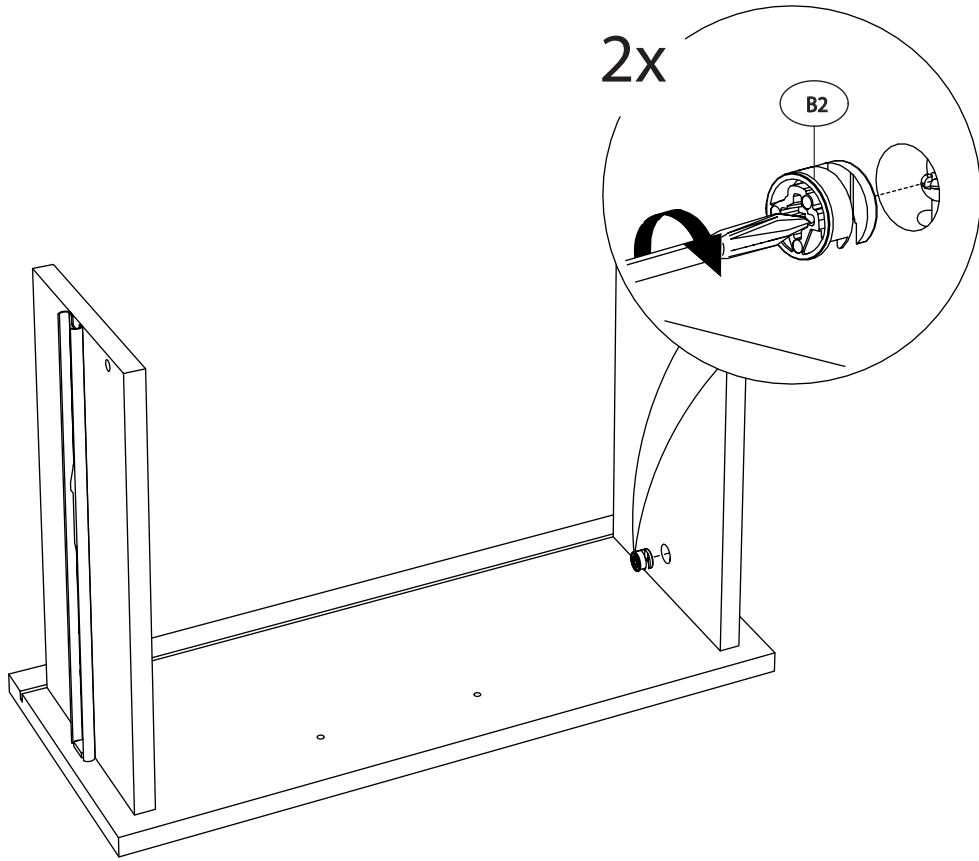

35.

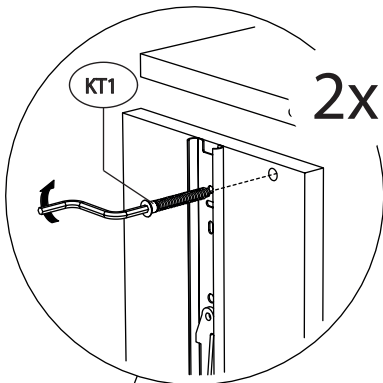

x3

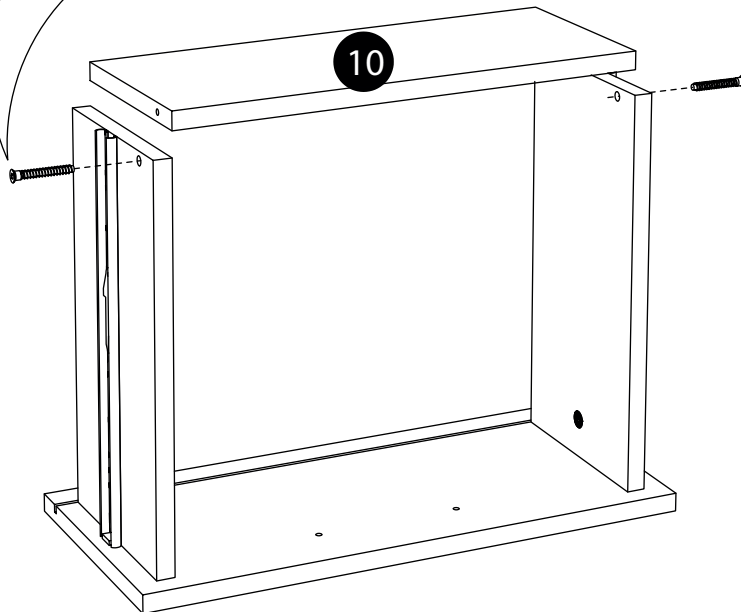

36.

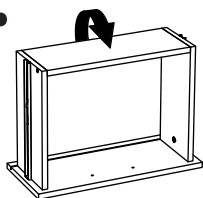

x3

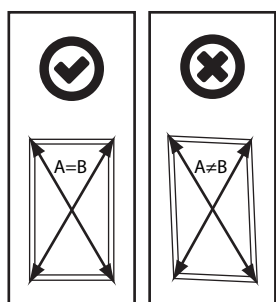
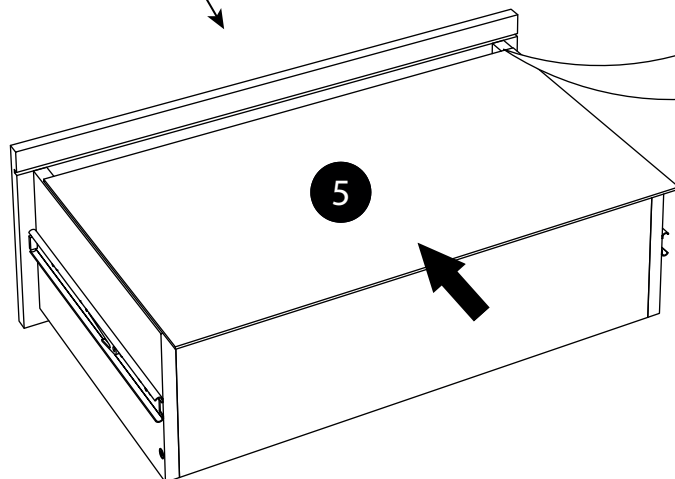

37.

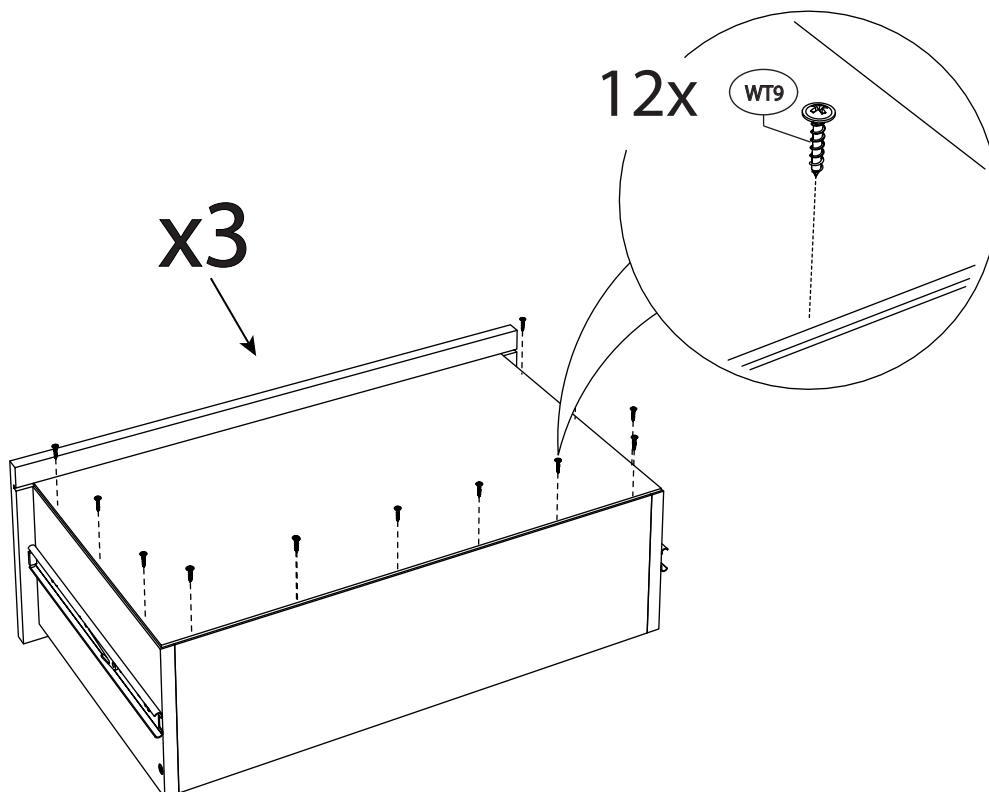

38.

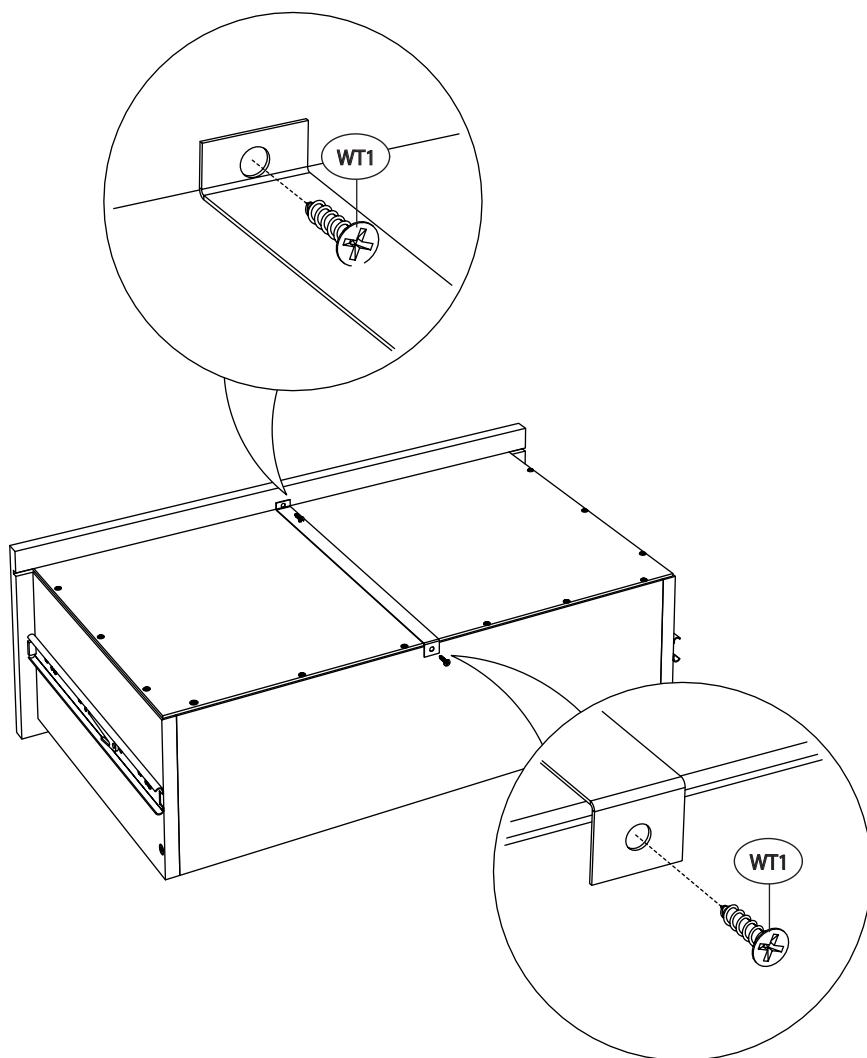

39.

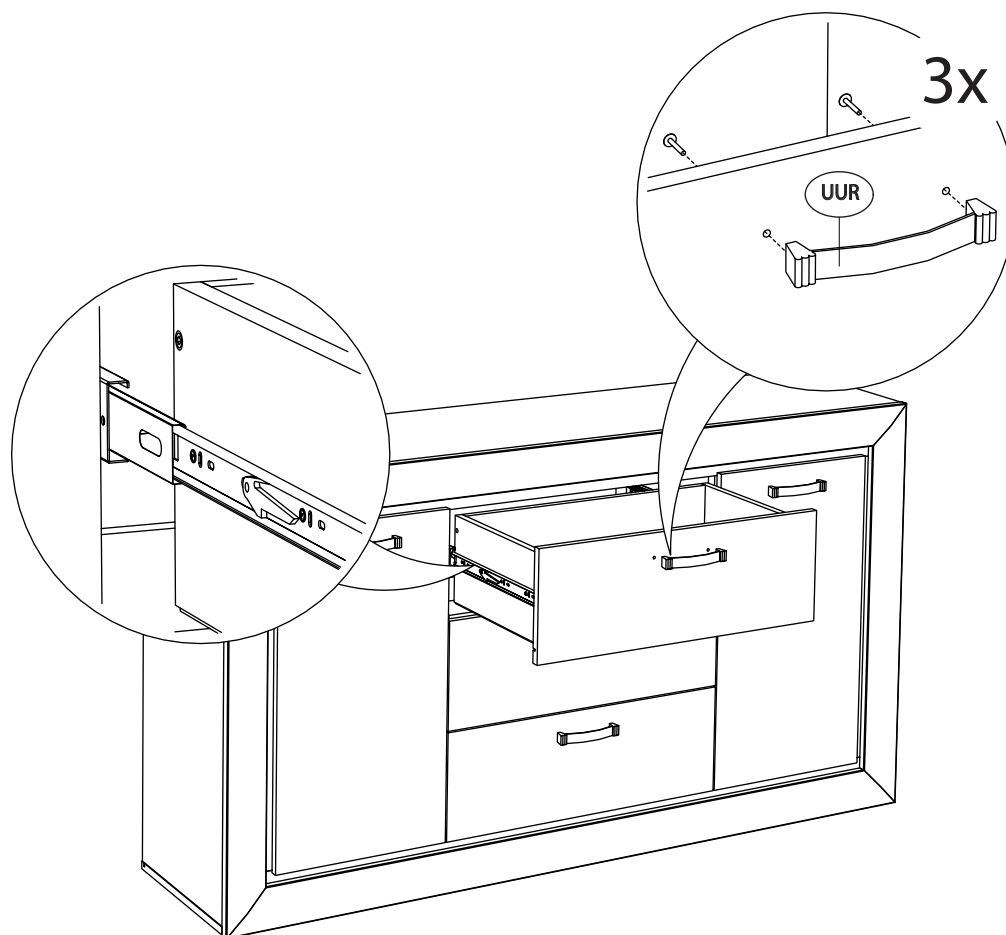



40.

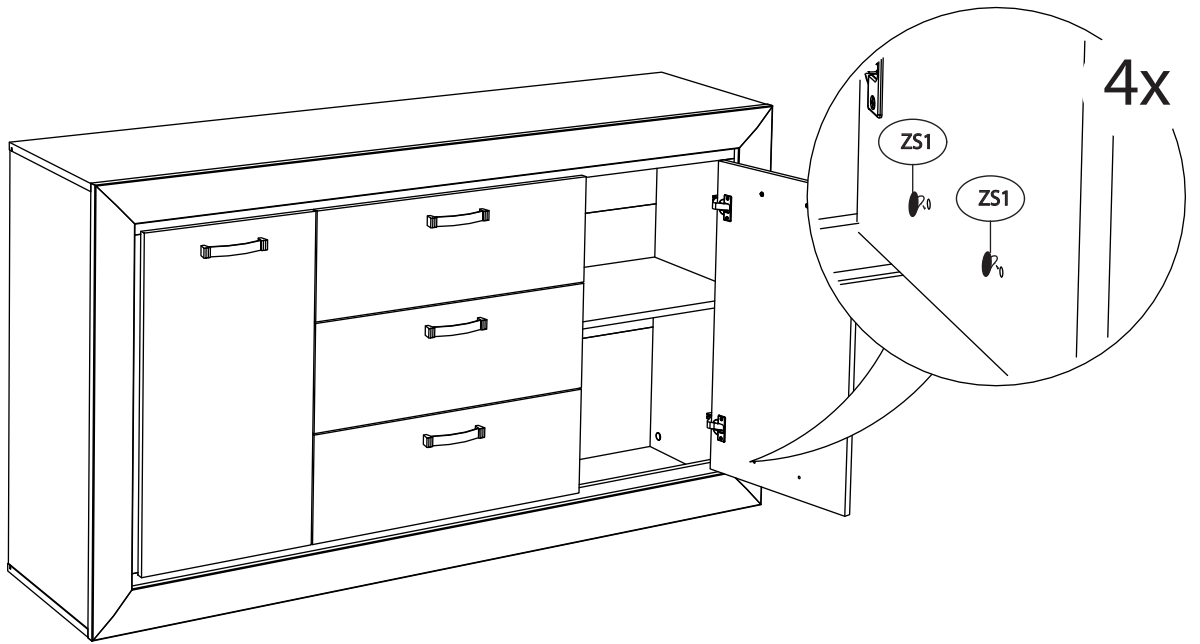

41.

