

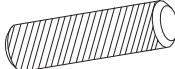

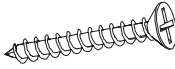

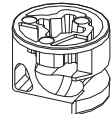

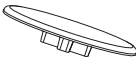







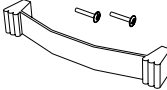

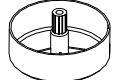

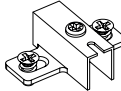
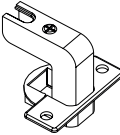
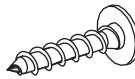
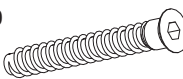
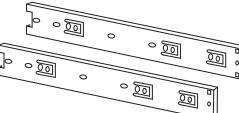
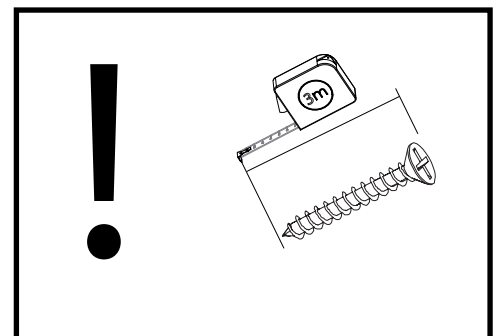
# MOCCA 06

<p><b>K1</b> x 36 8x32</p> 	<p><b>WT18</b> x 16 4x30</p> 	<p><b>B2</b> x 52 h-12</p> 
<p><b>ZM1</b> x 44 Ø18</p> 	<p><b>WT1</b> x 8 3,5x15</p> 	<p><b>ZD1</b> x 4 L68</p> 
<p><b>ZJ1</b> x 44 L-43</p> 	<p><b>PO2</b> x 8 Ø5</p> 	<p><b>SP</b> x 12</p> 
<p><b>UUR</b> x 5 L-128</p> 	<p><b>WE7</b> x 18 6,3x13ES</p> 	<p>x 1</p> 
<p><b>SMO</b> x 6 Ø50 h25</p> 	<p><b>ZS1</b> x 4 Ø13</p> 	<p><b>PK6</b> x 4</p> 
<p><b>ZP10</b> x 4</p> 	<p><b>WT9</b> x 45 3x16</p> 	<p><b>KT1</b> x 10 6,3x50</p> 
<p><b>P1</b> x 3 L-350</p> 		



# MOCCA 06

	CODE				
1	Mocca06HDF_02	1354	295	3	2/3
2	Mocca06_03	878	400	1	1/3
3	Mocca06_03	878	400	1	1/3
4	Mocca06_10	180	350	3	1/3
5	Mocca06HDF_01	344	355	3	2/3
6	Mocca06_09	388	230	3	1/3
7	Mocca06_16	1378	88	2	3/3
8	Mocca06_08	384	696	2	1/3
9	Mocca06_13	1342	96	2	2/3
10	Mocca06_12	180	316	3	2/3
11	Mocca06_02	1378	400	1	2/3
12	Mocca06_01	1378	400	1	2/3

	CODE				
13	Mocca06_15	912	88	2	3/3
14	Mocca06_07	468	365	2	2/3
15	Mocca06_05	878	368	1	2/3
16	Mocca06_06	878	368	1	2/3
17	Mocca06_11	180	350	3	1/3
18	Mocca06_14	685	92	2	1/3
19	Mocca06_04	373	92	1	2/3

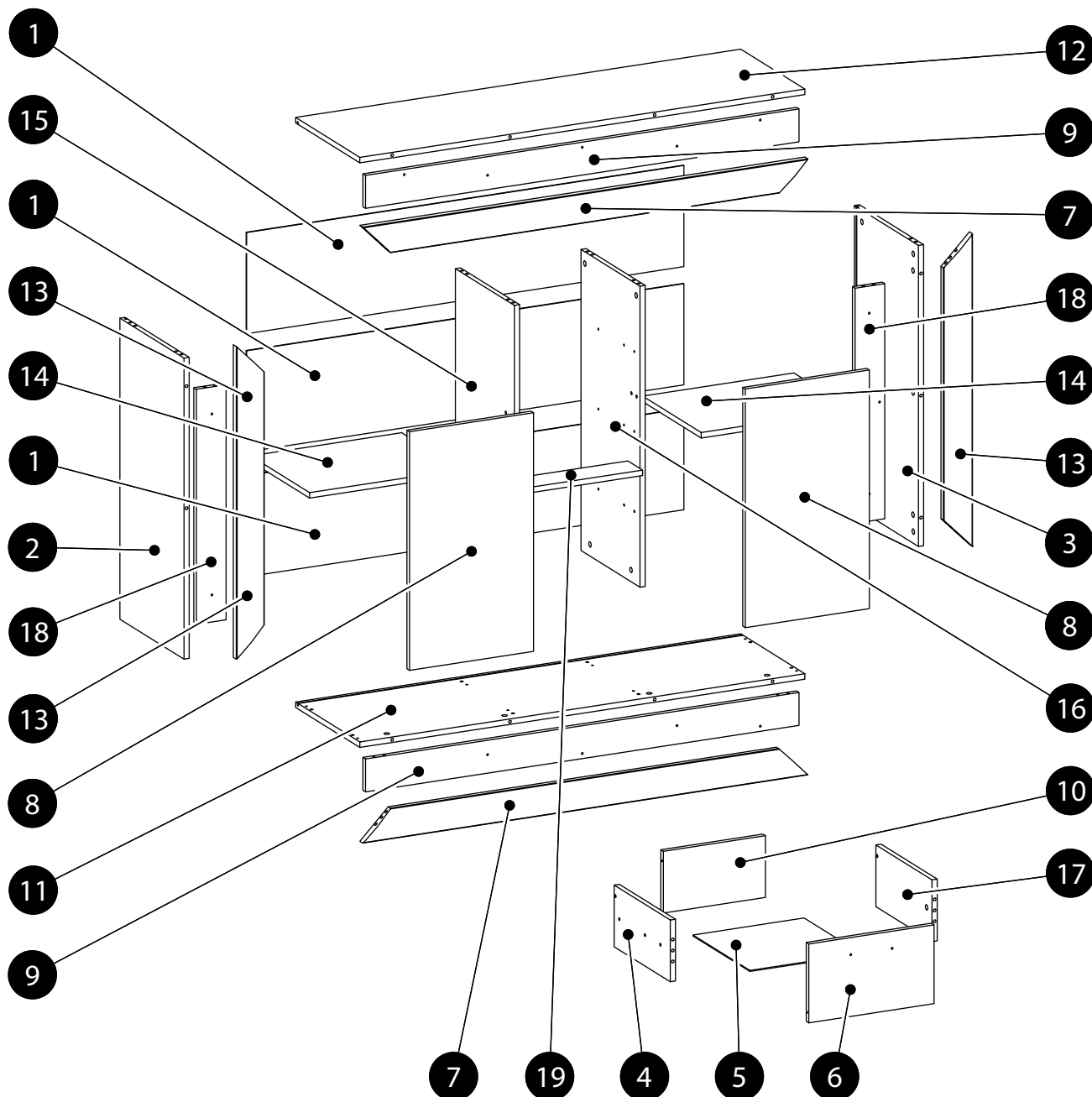

1.

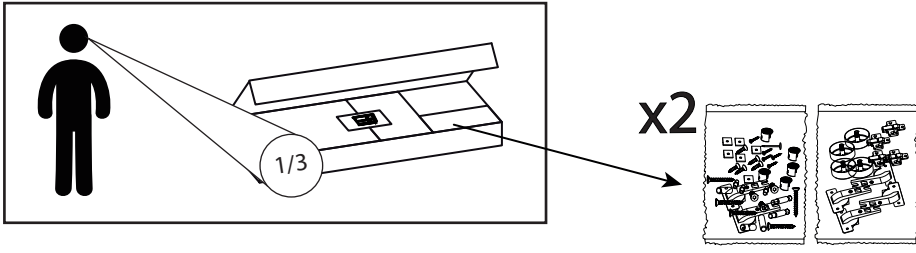

2.

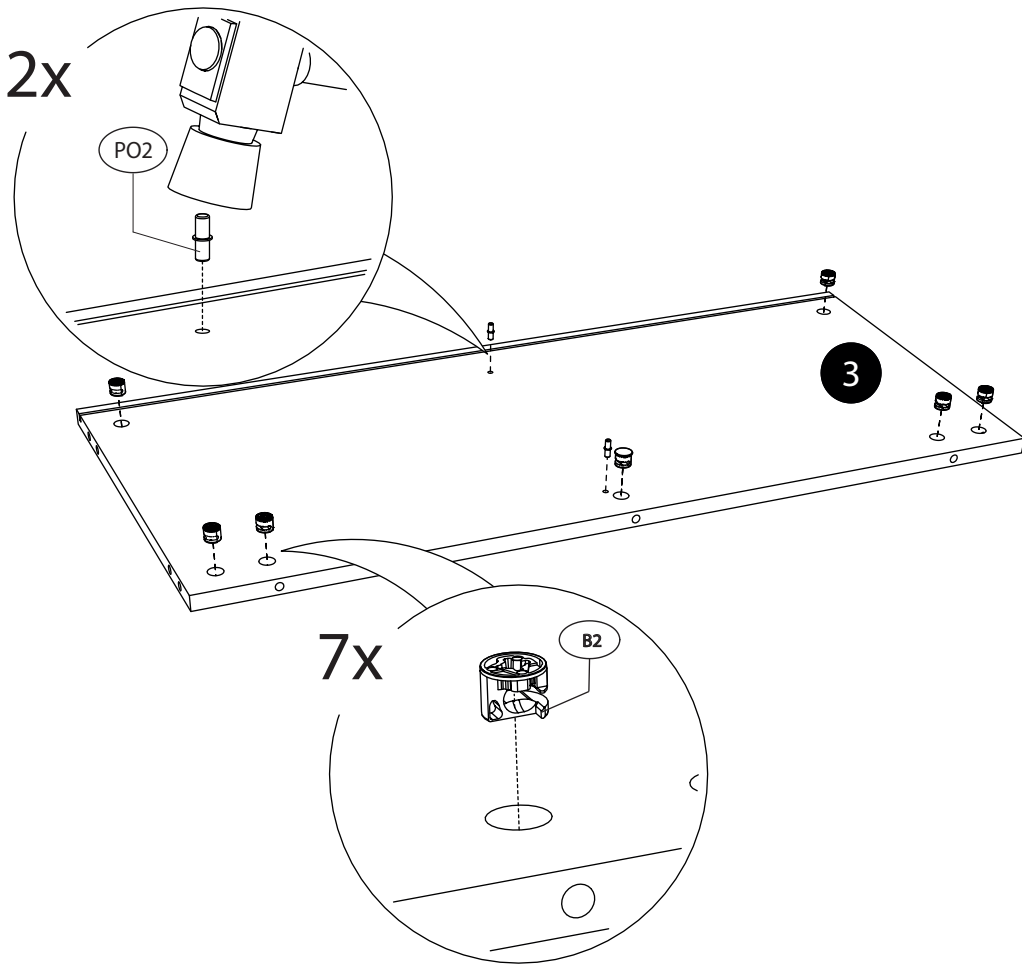

3.

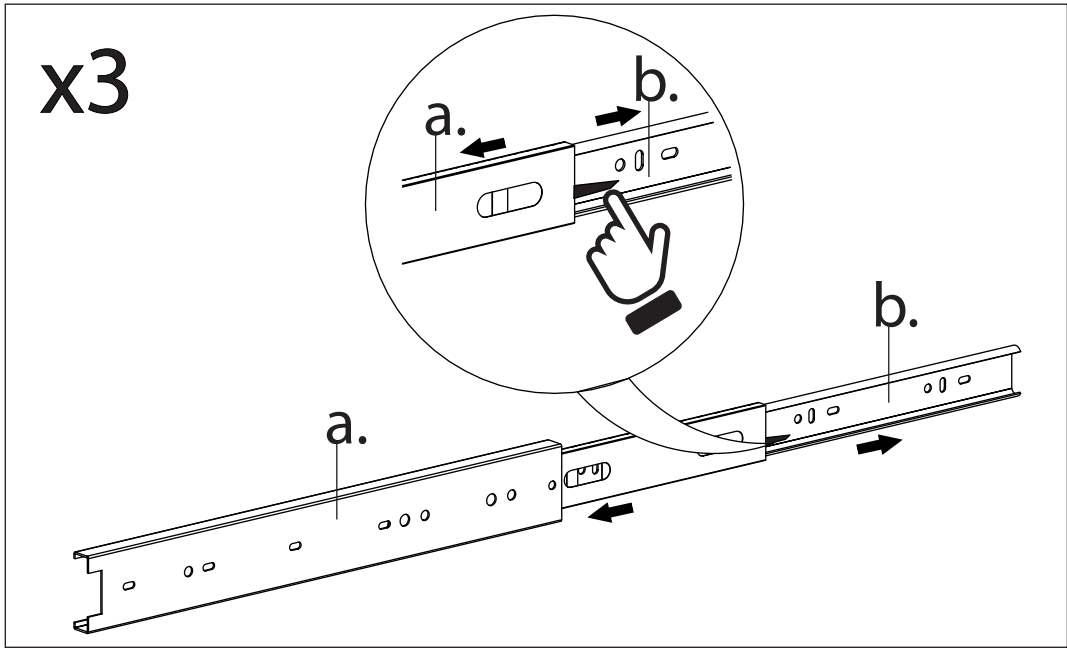

4.

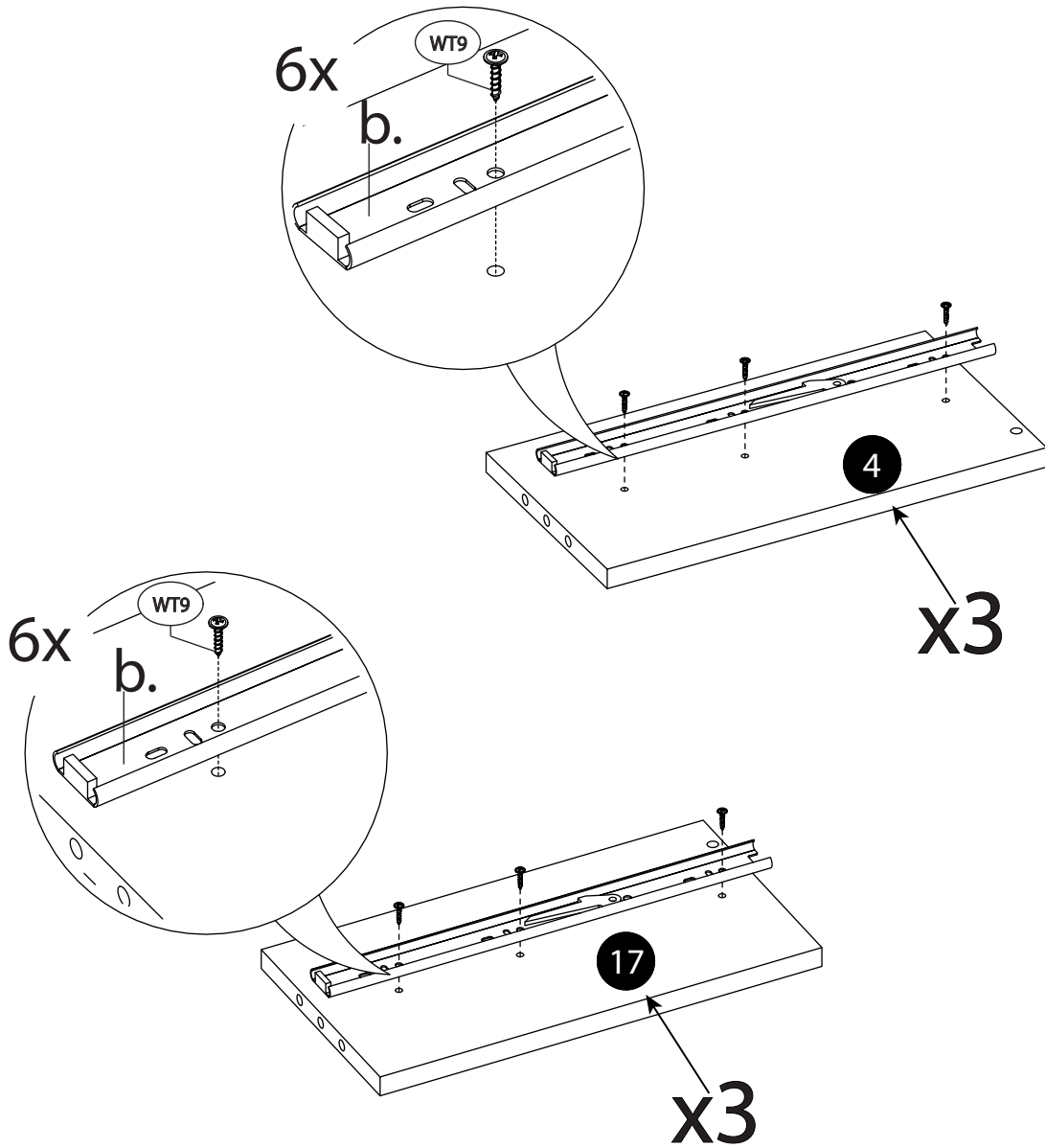

5.

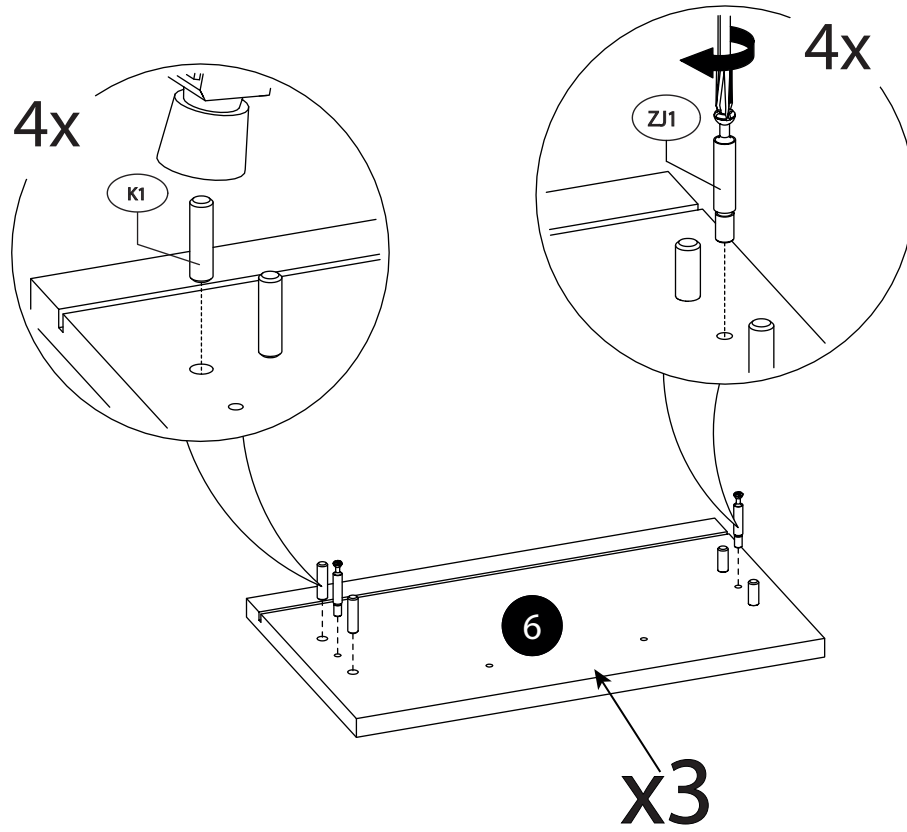

6.

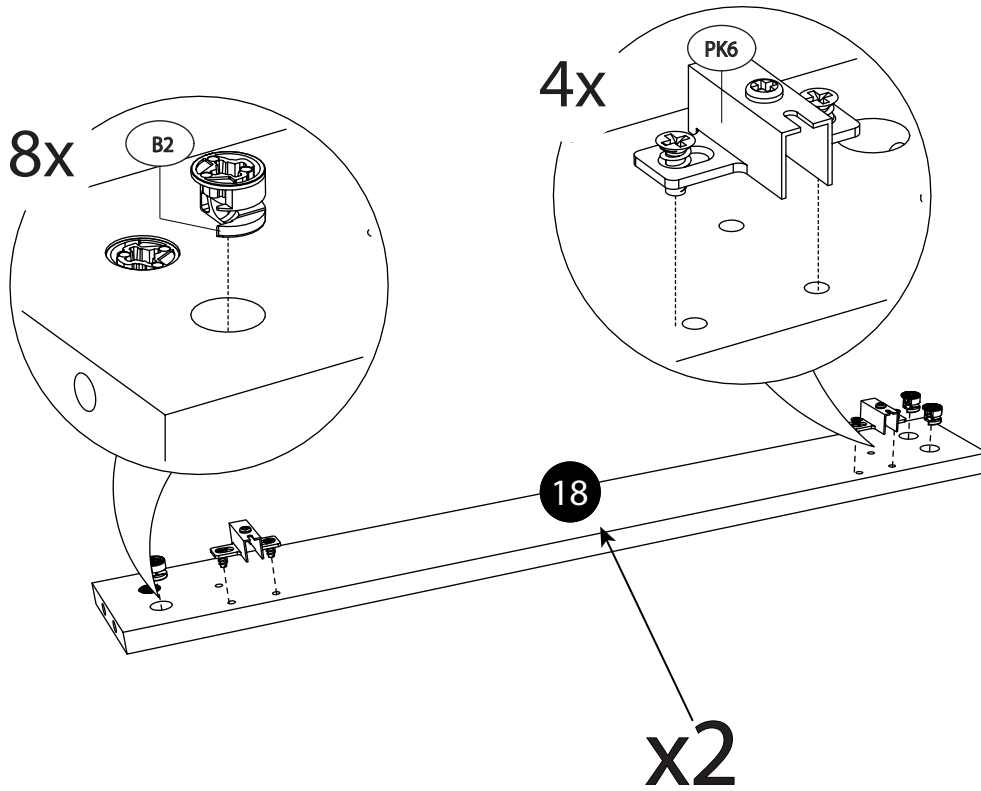

7.

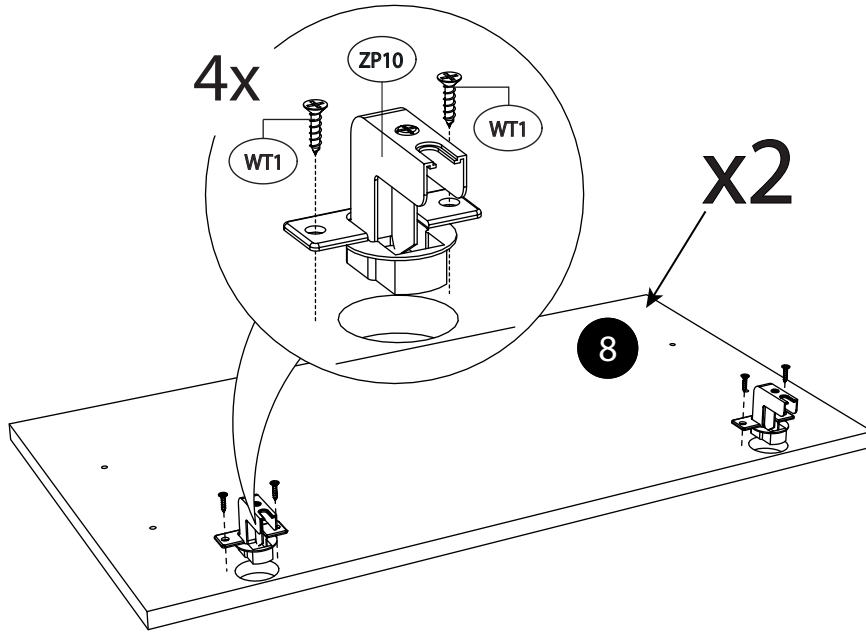

8.

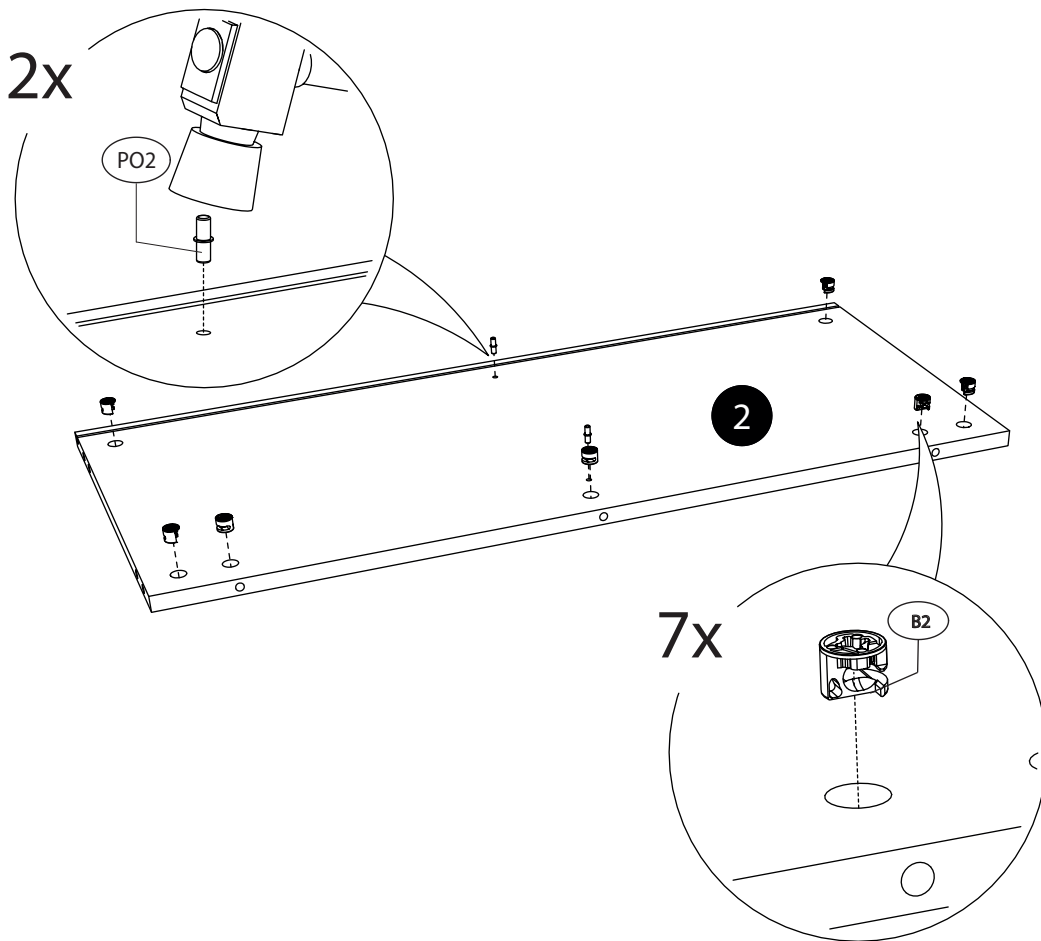



9.

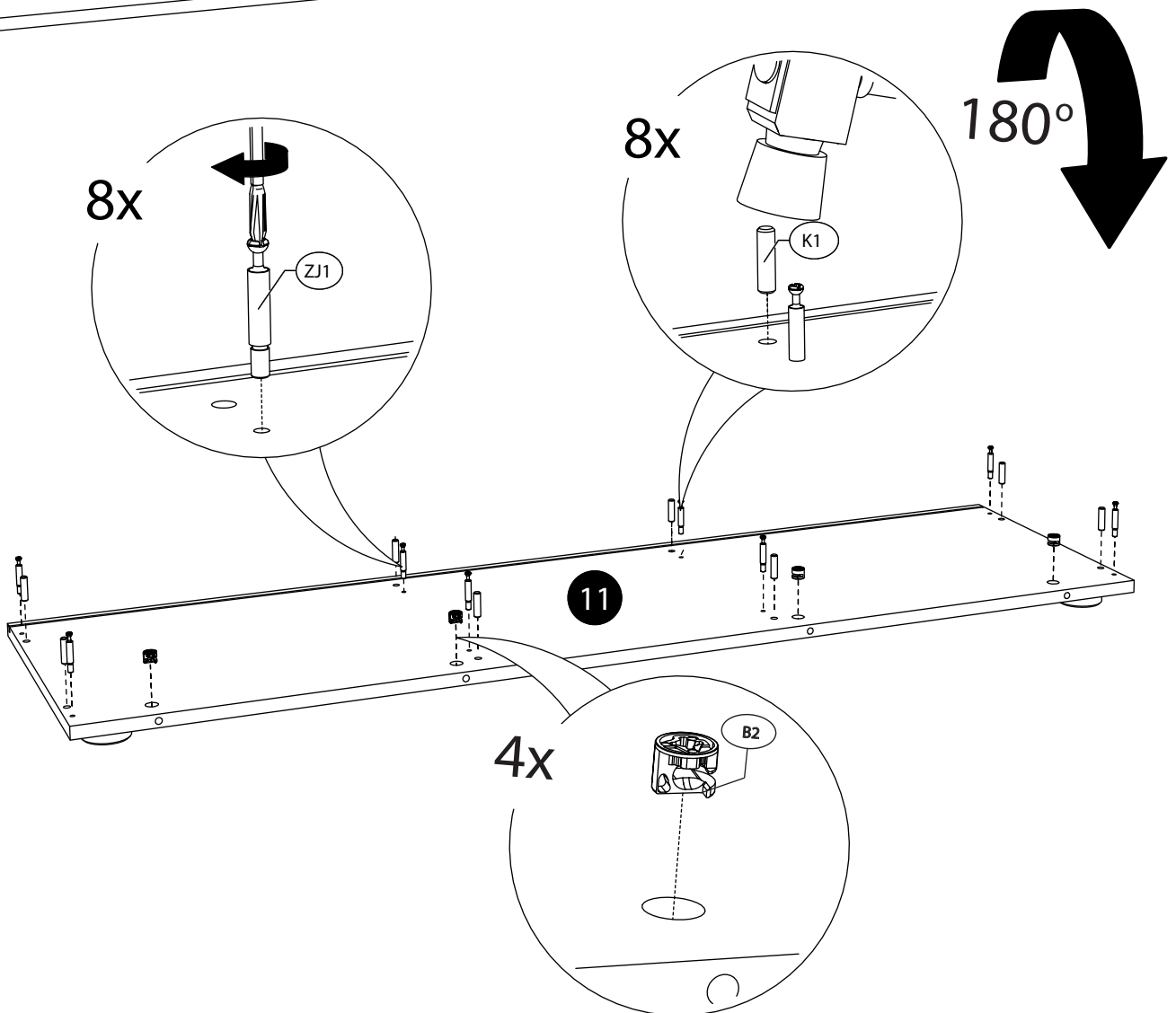
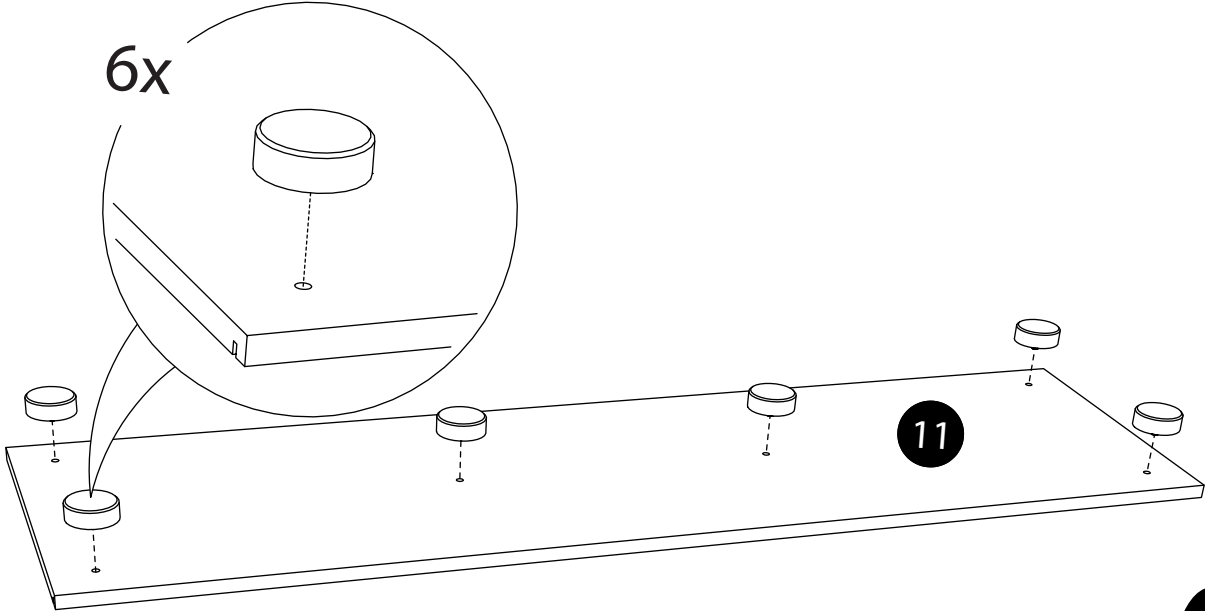
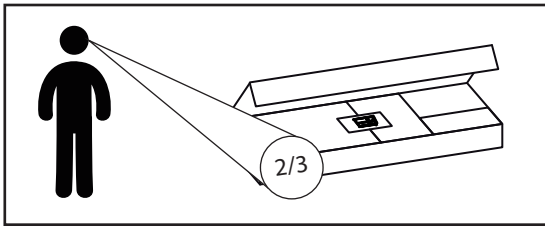

10.

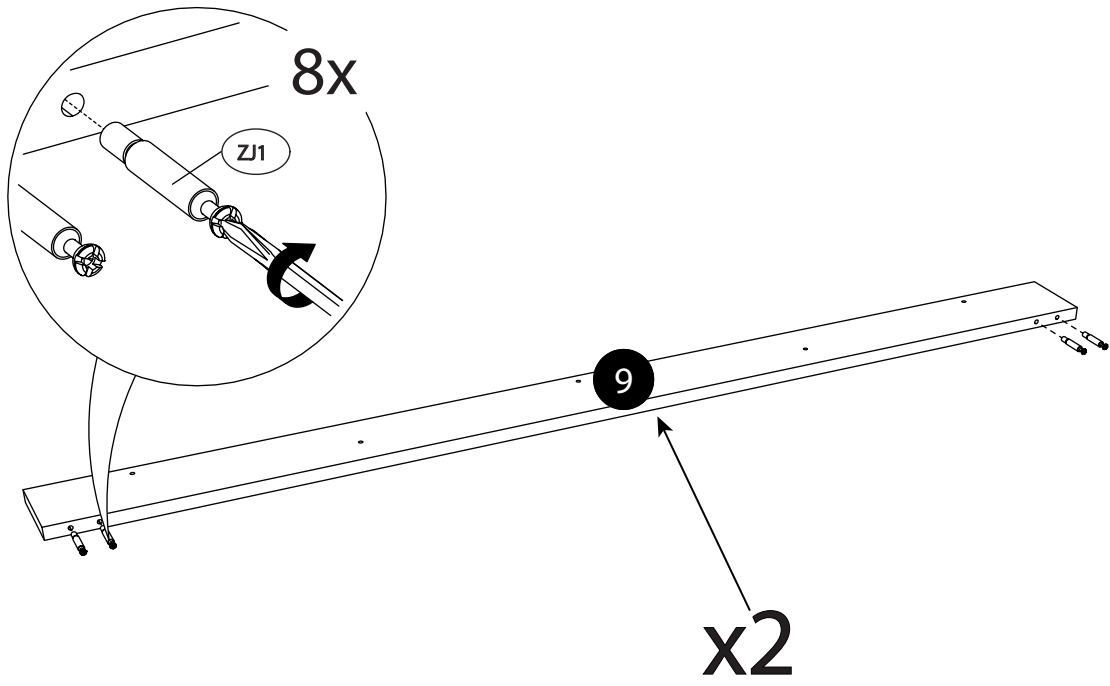

11.

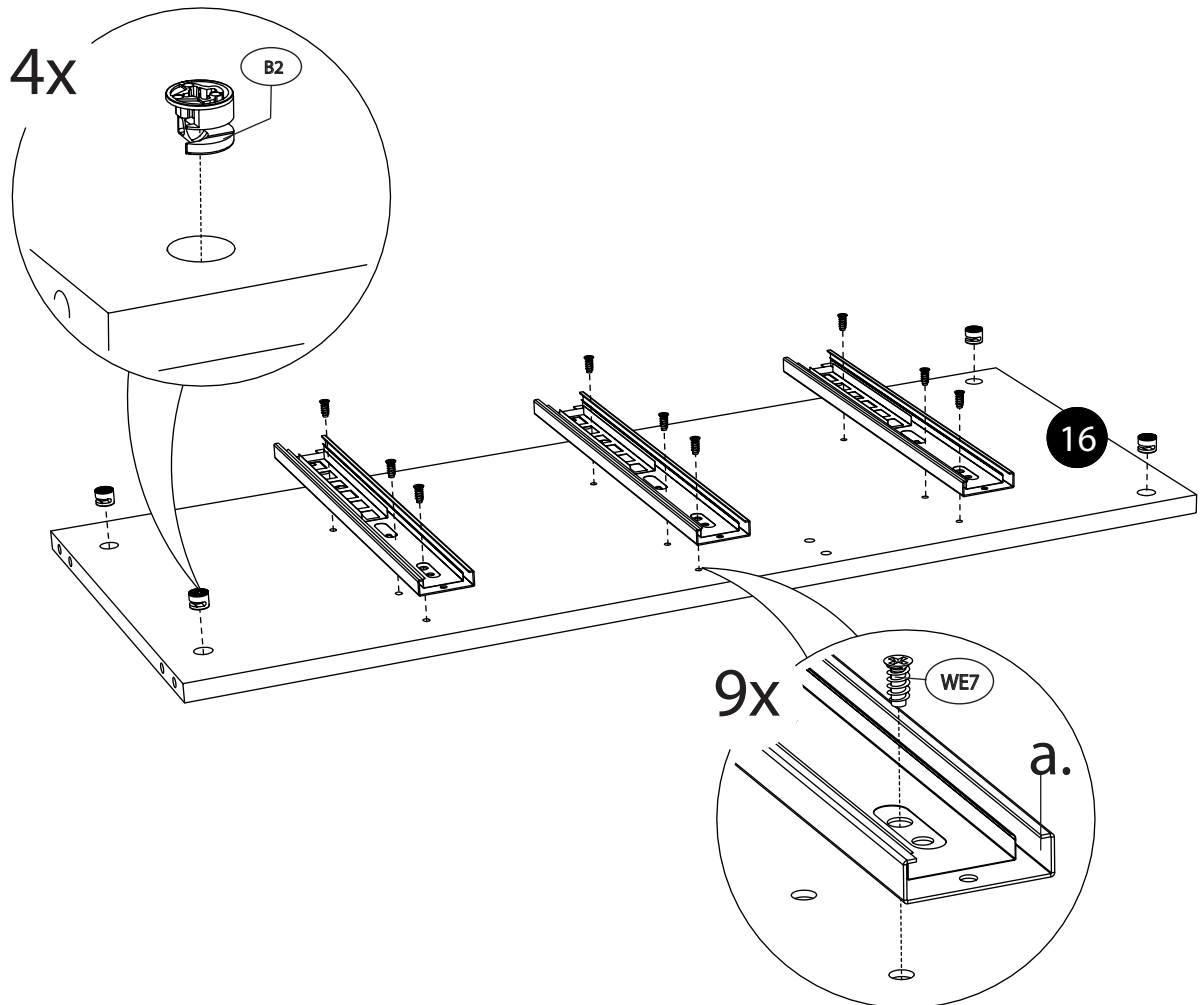

12.

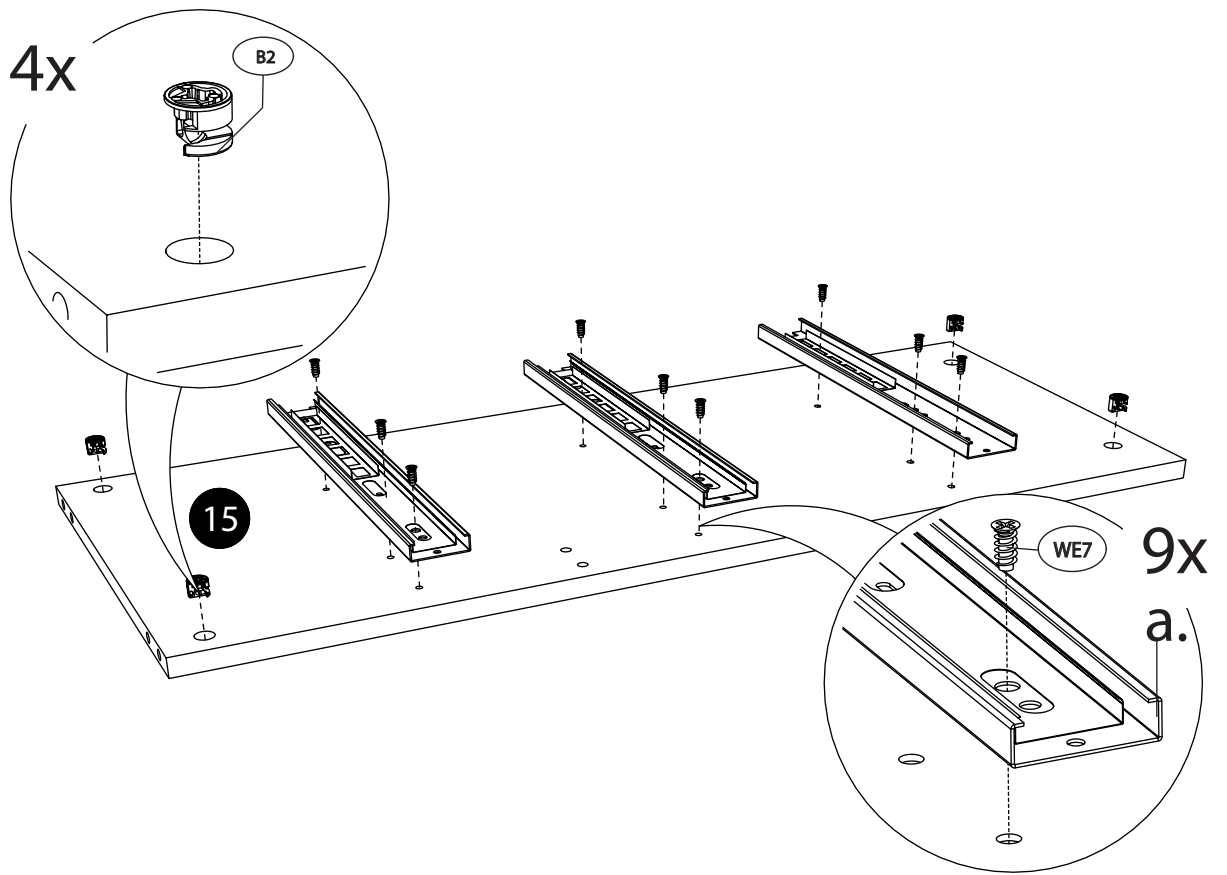

13.

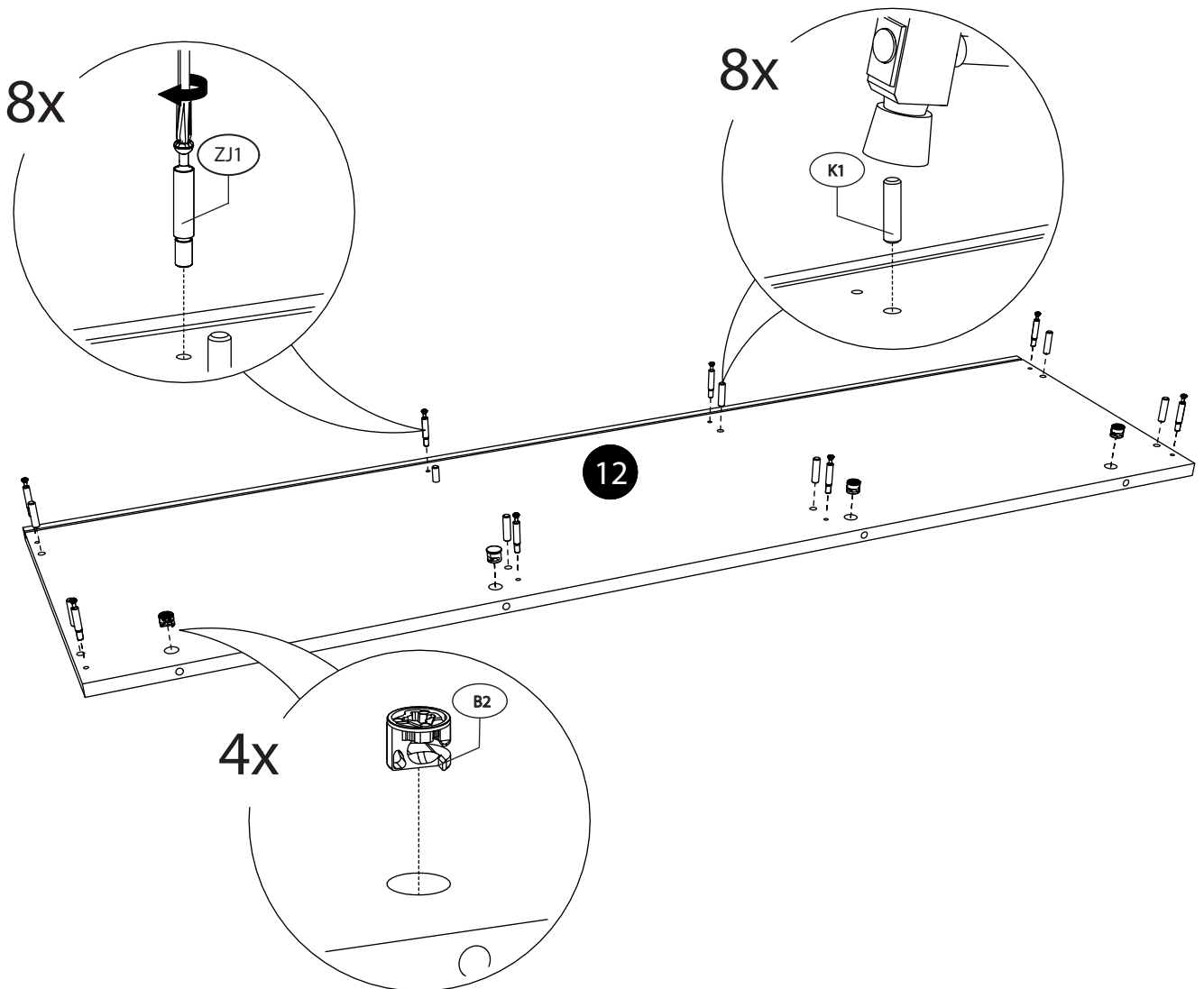

14.

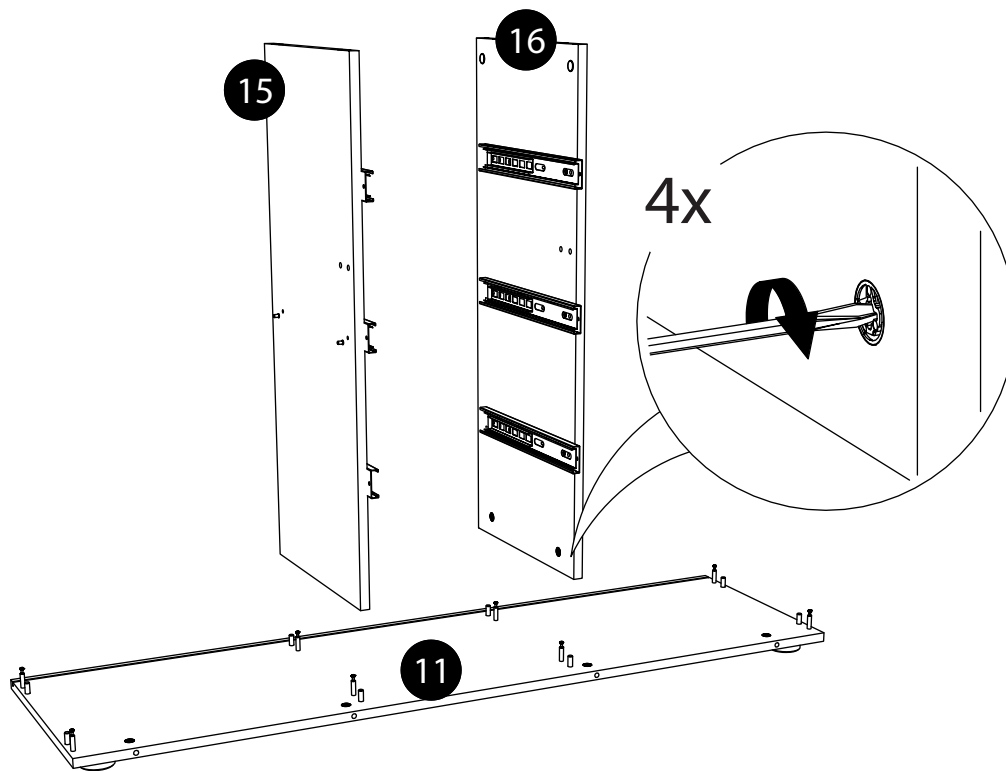

15.

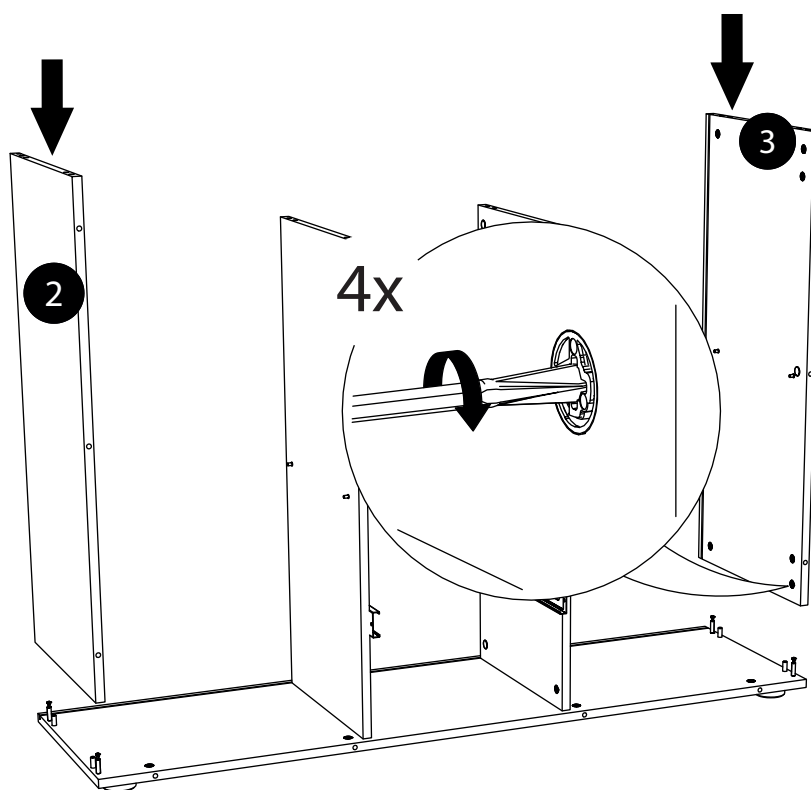

16.

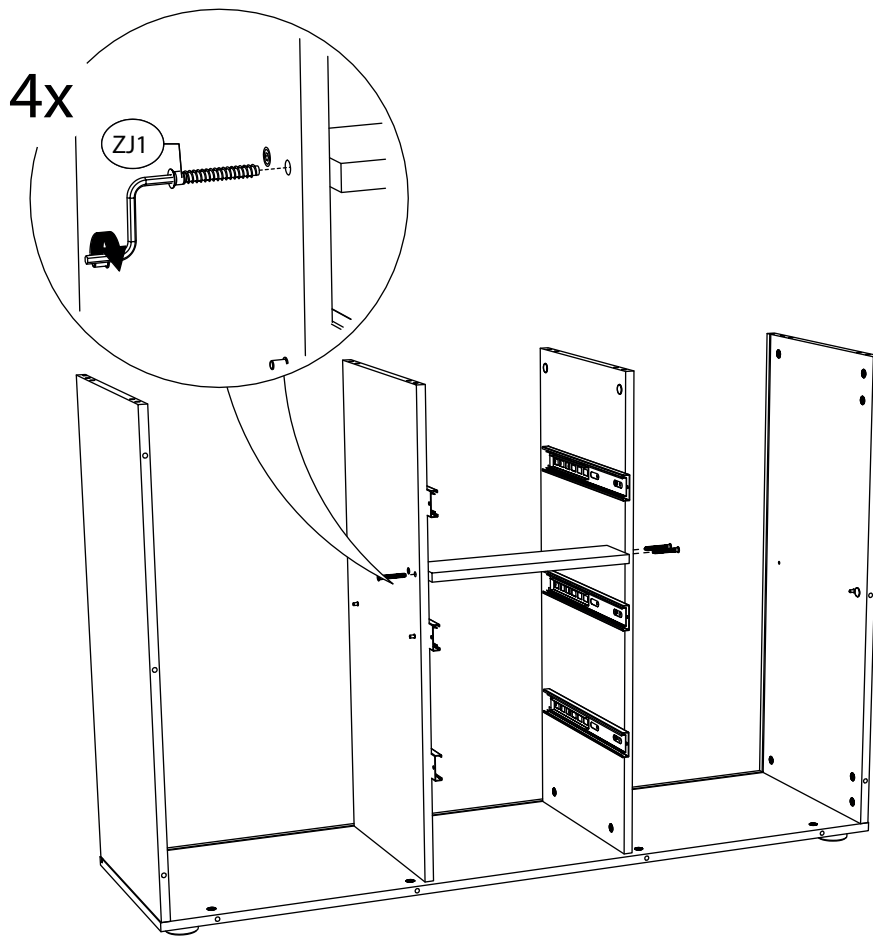

17.

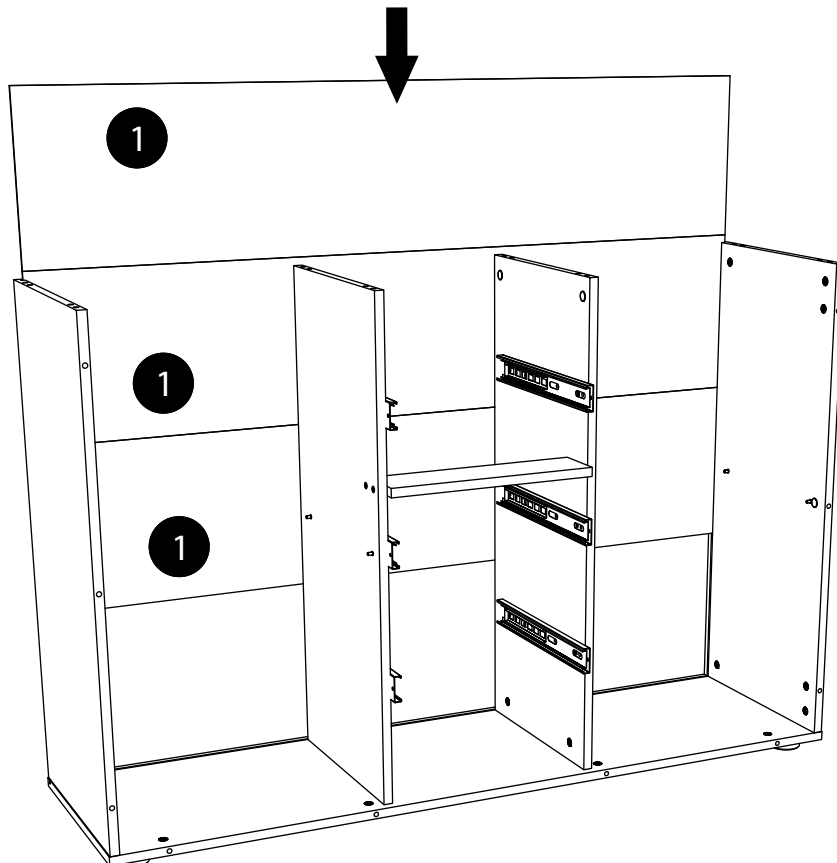

# 18.

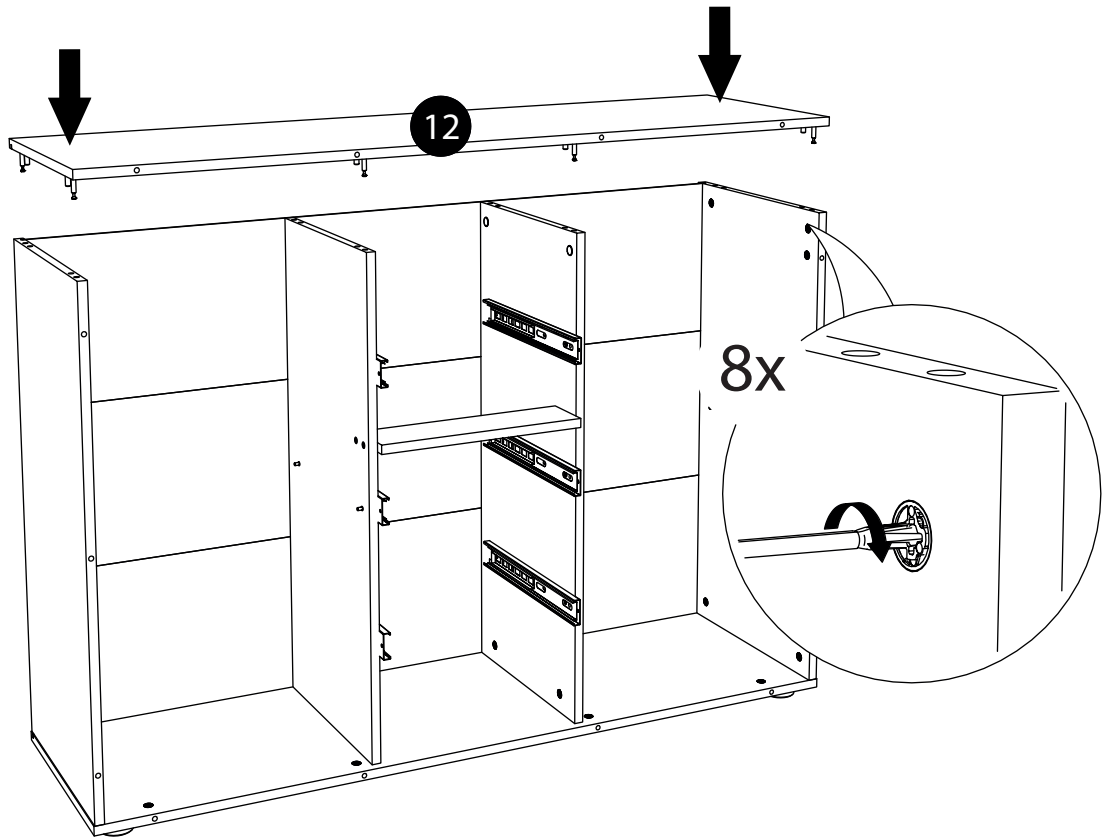

# 19.

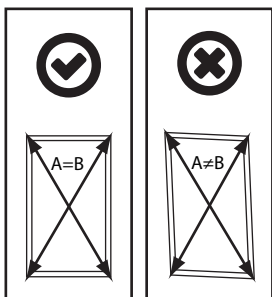
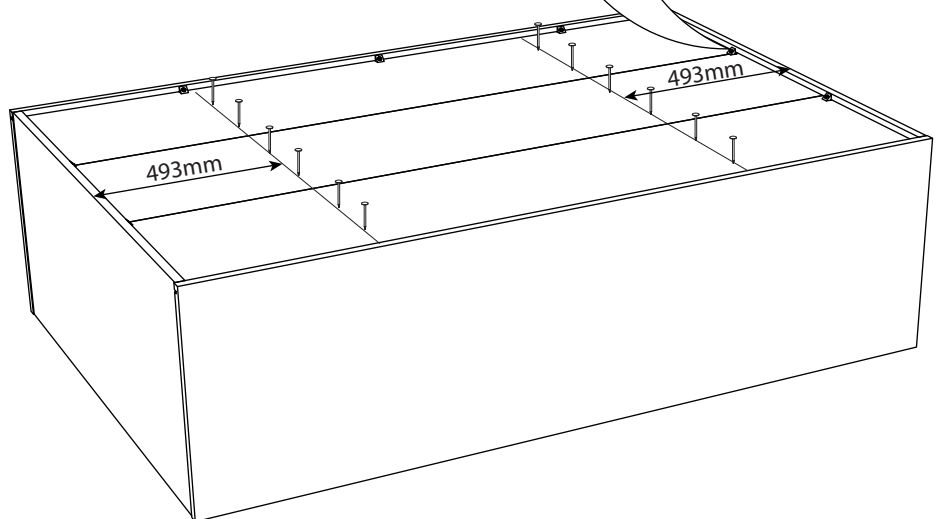
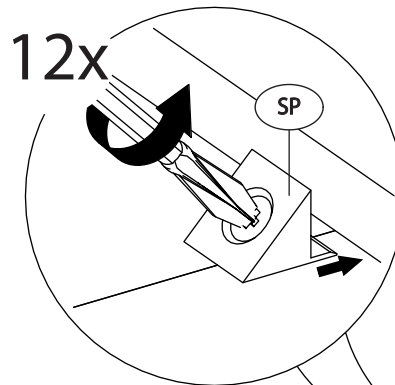
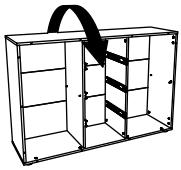

20.

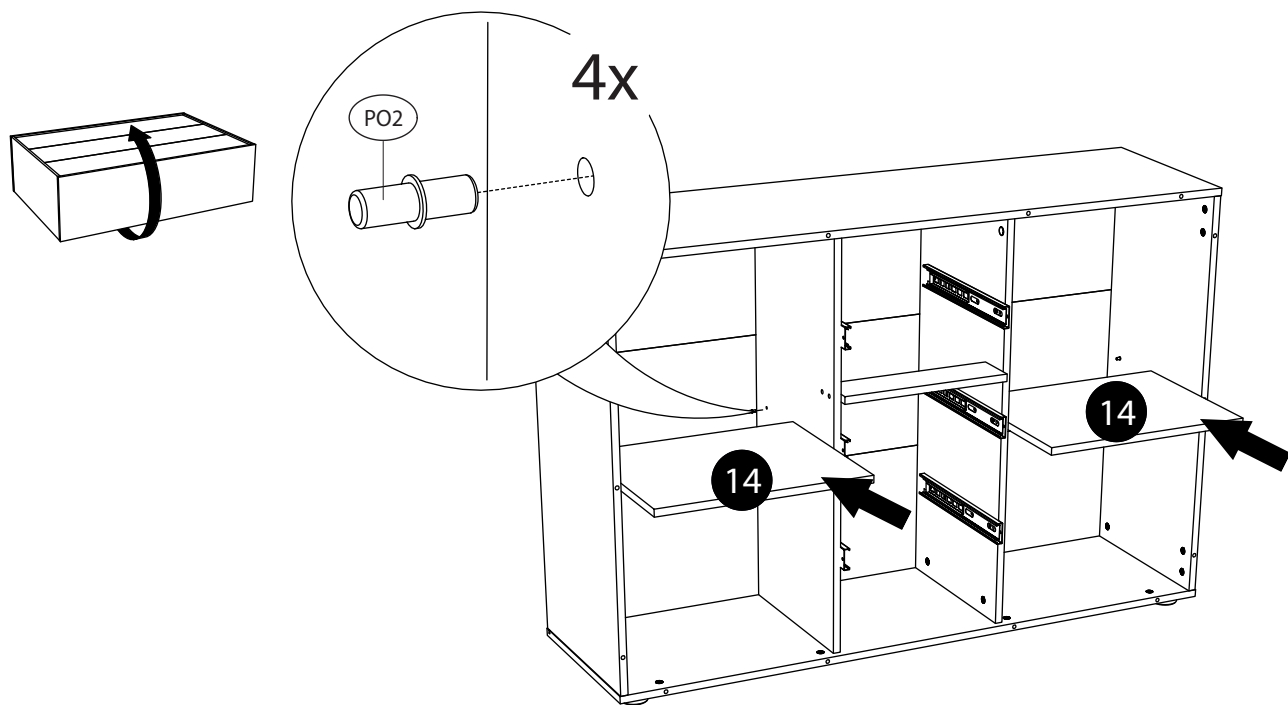

21.

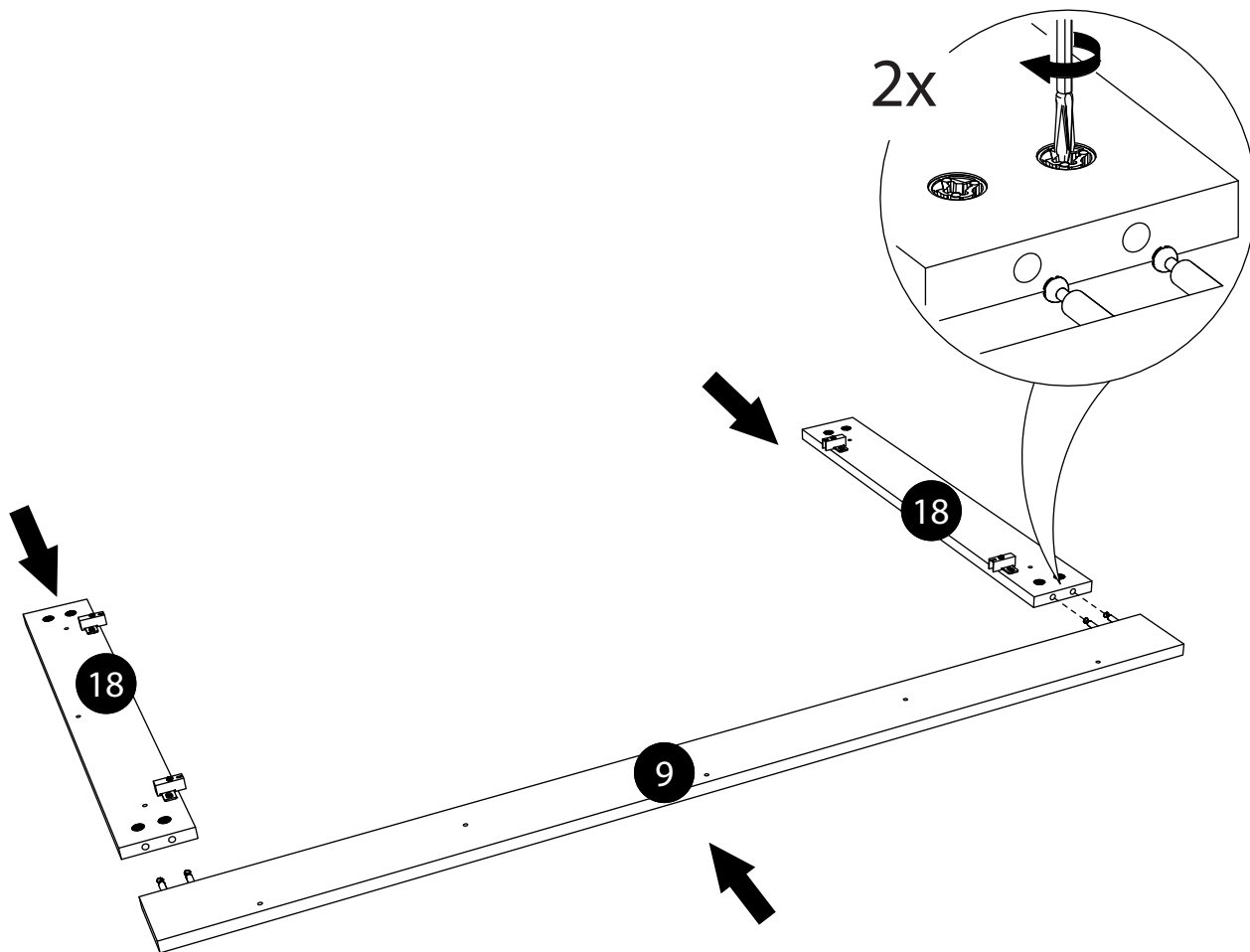

22.

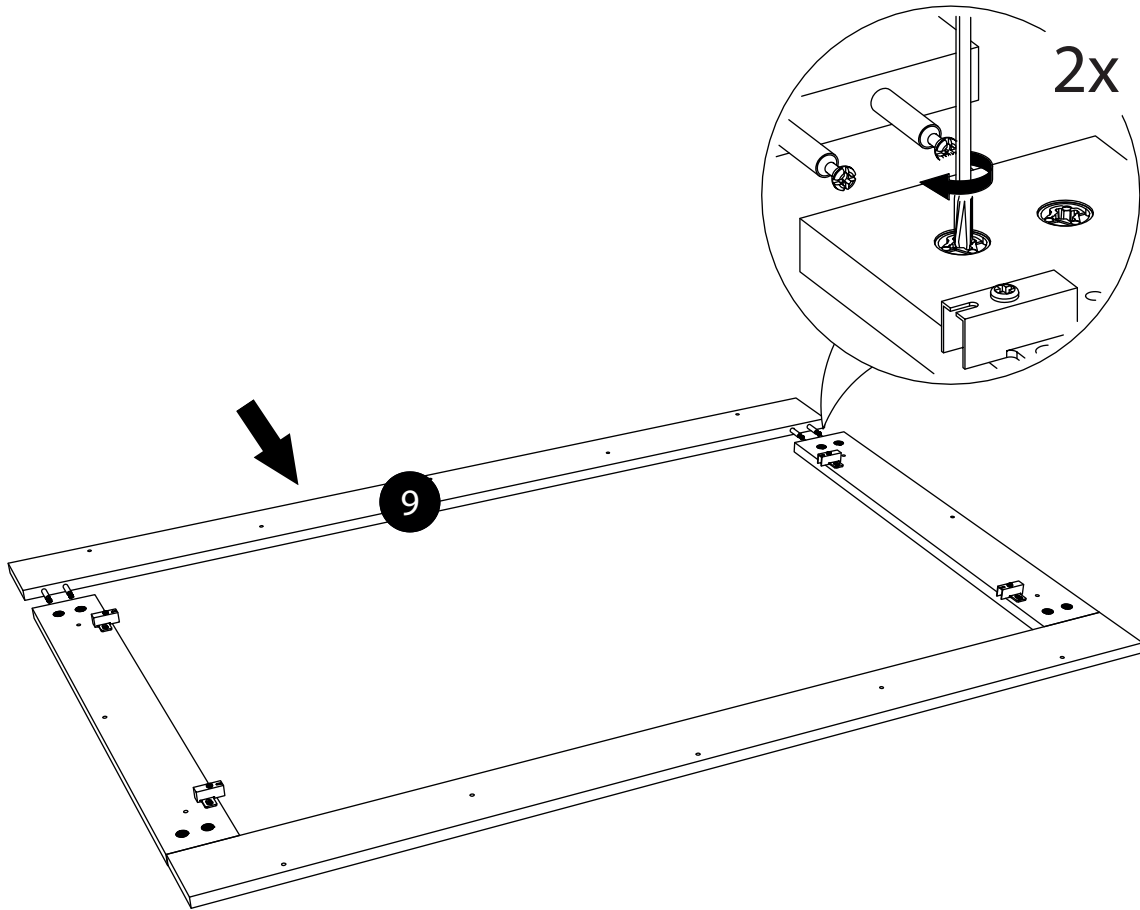

23.

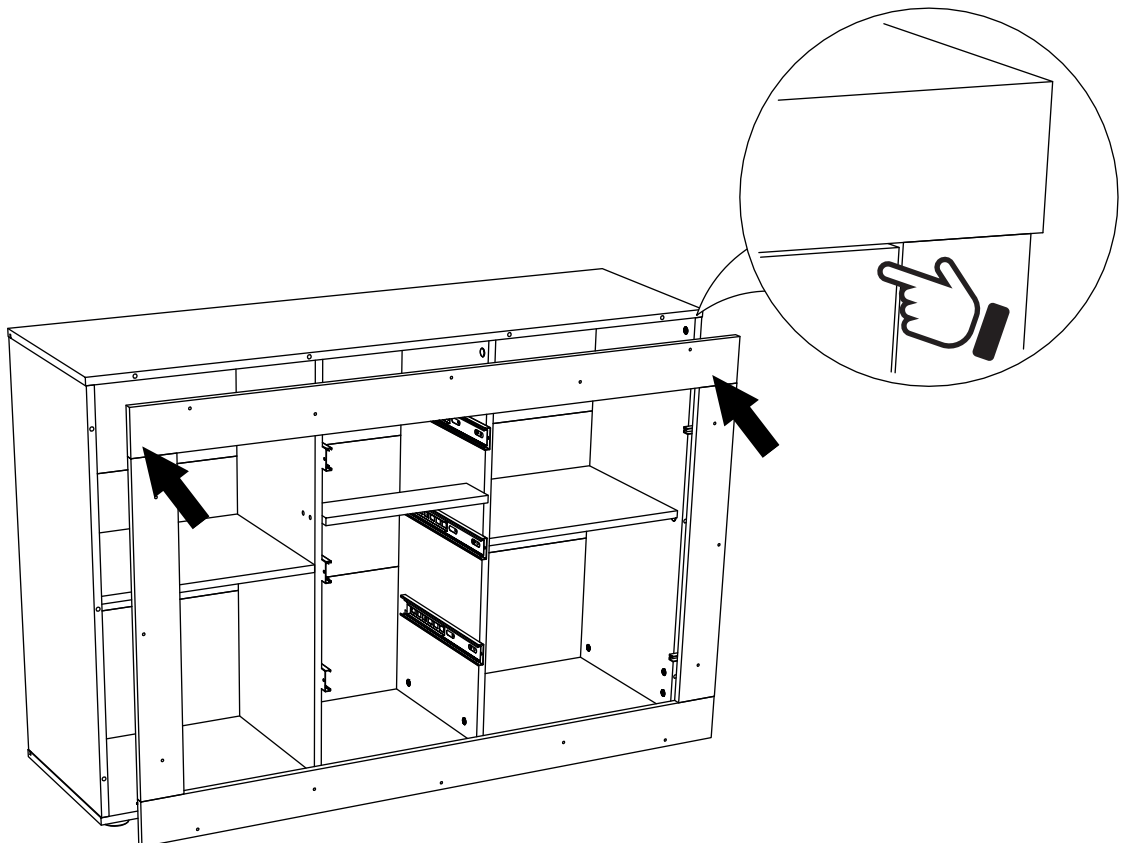



24.

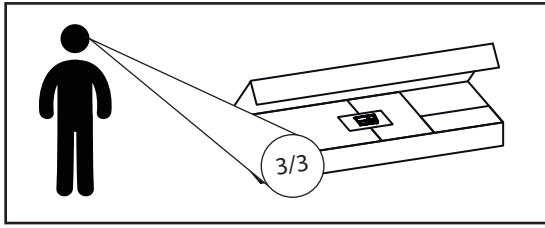

25.

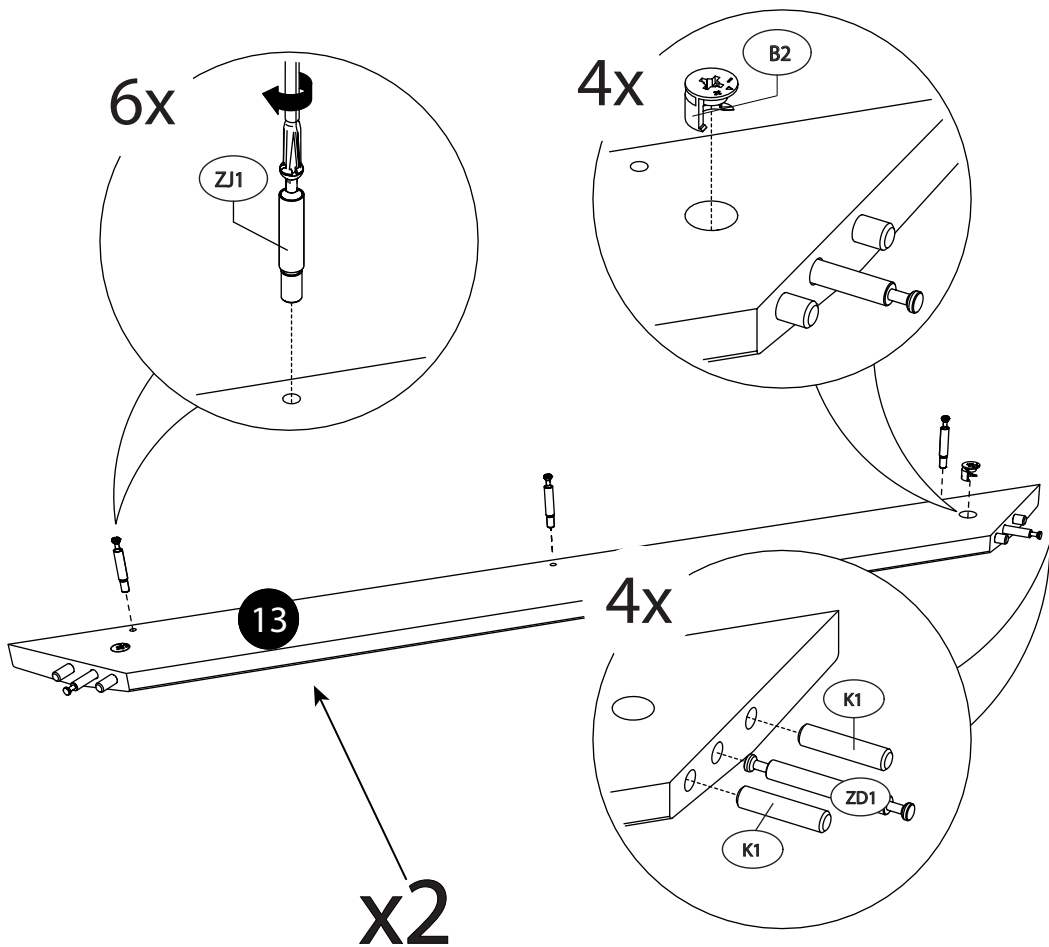
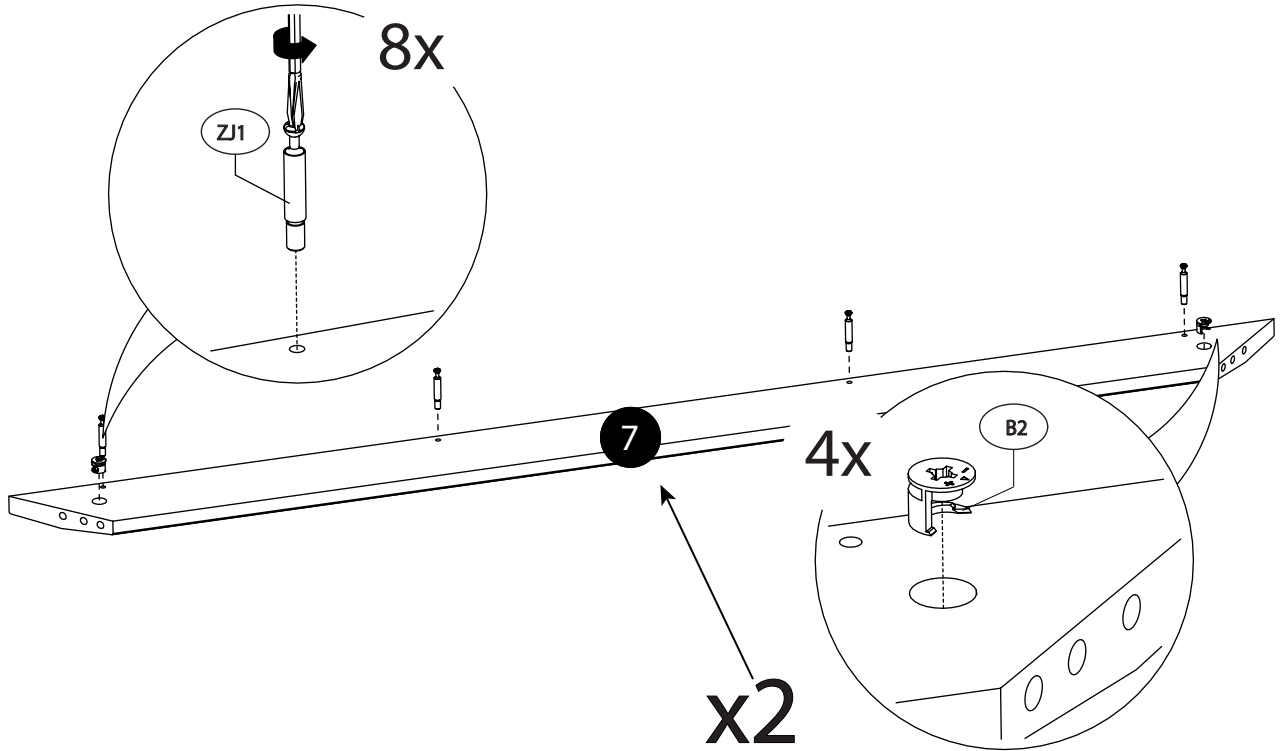

26.

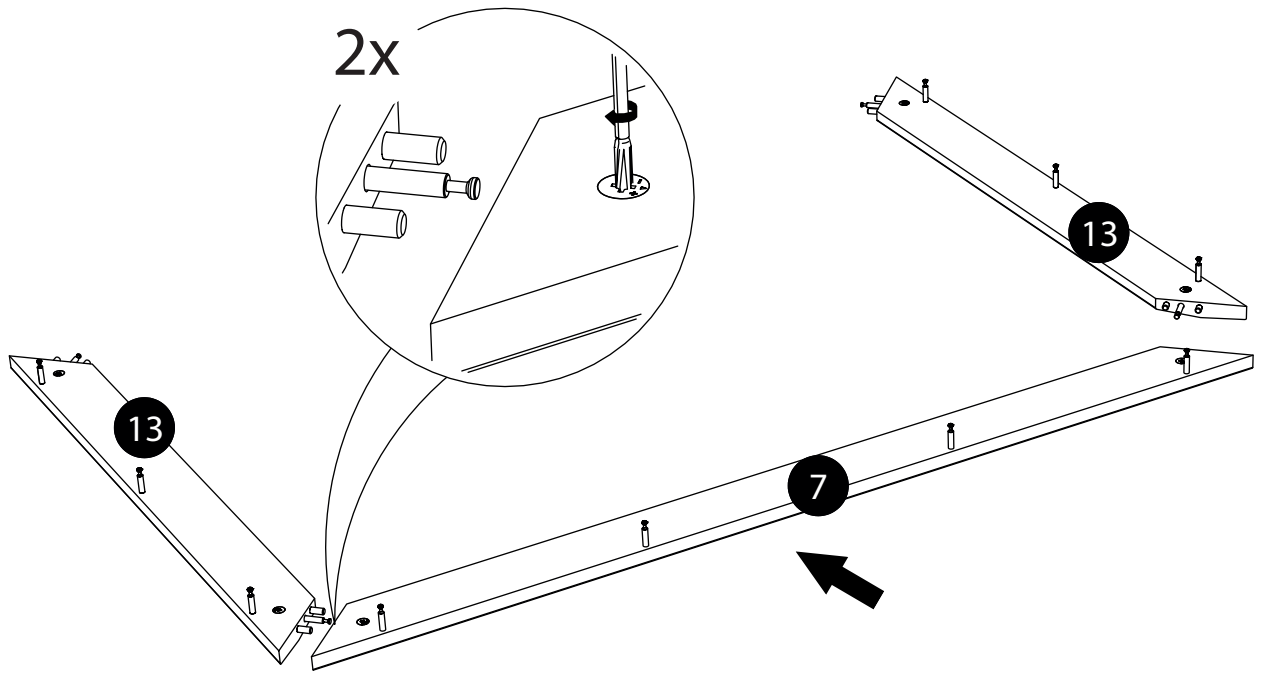

27.

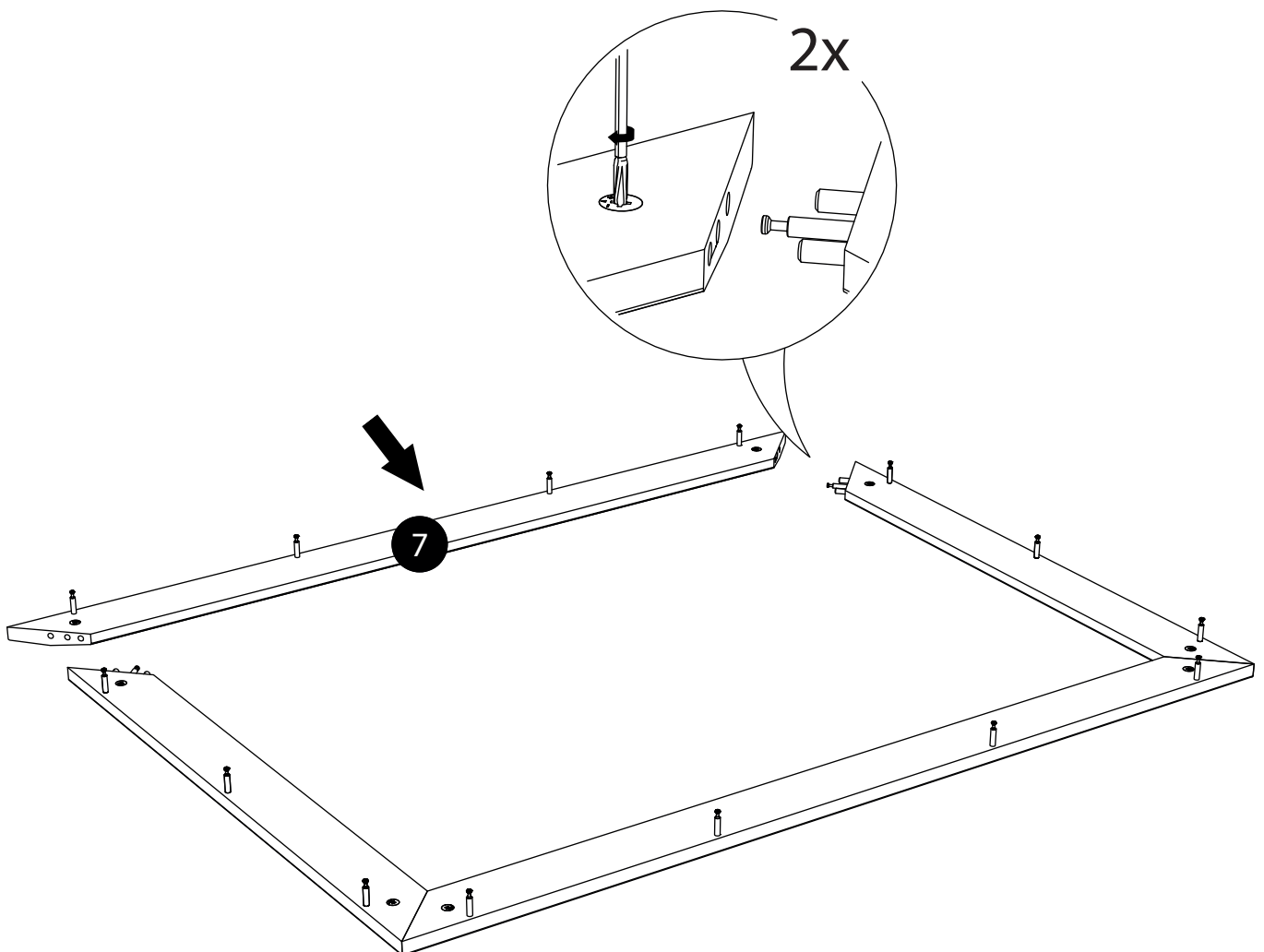

28.

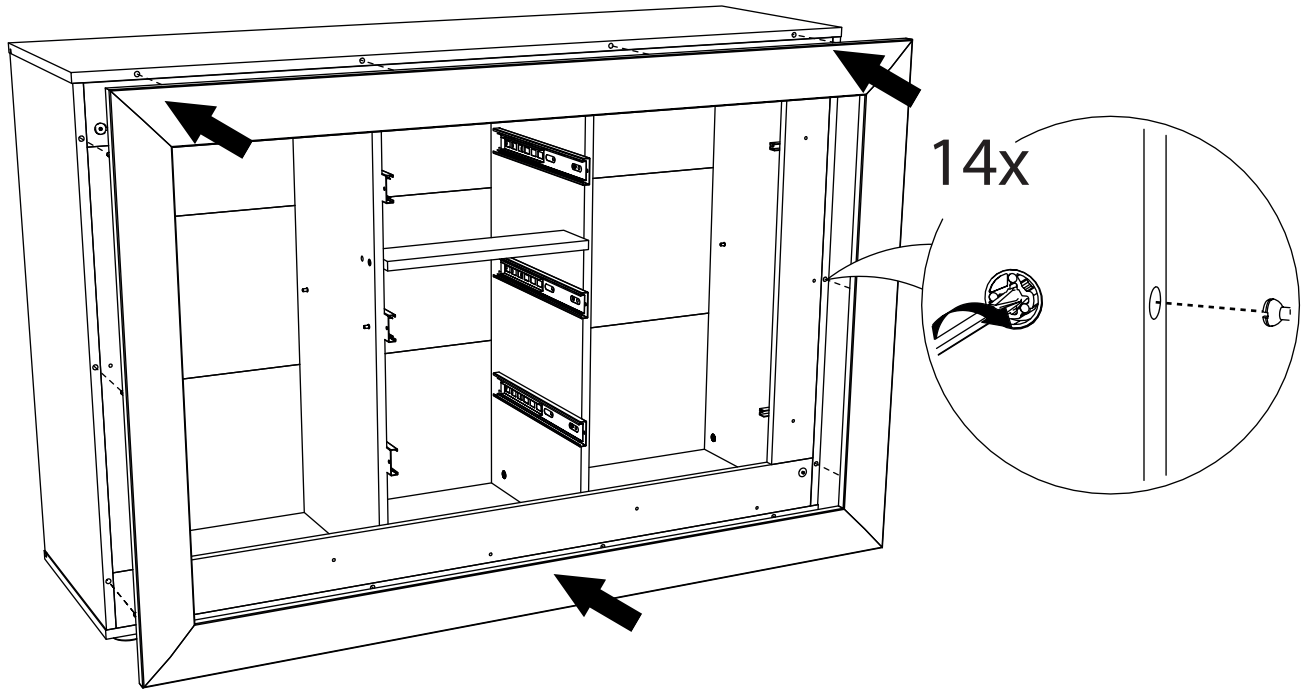

29.

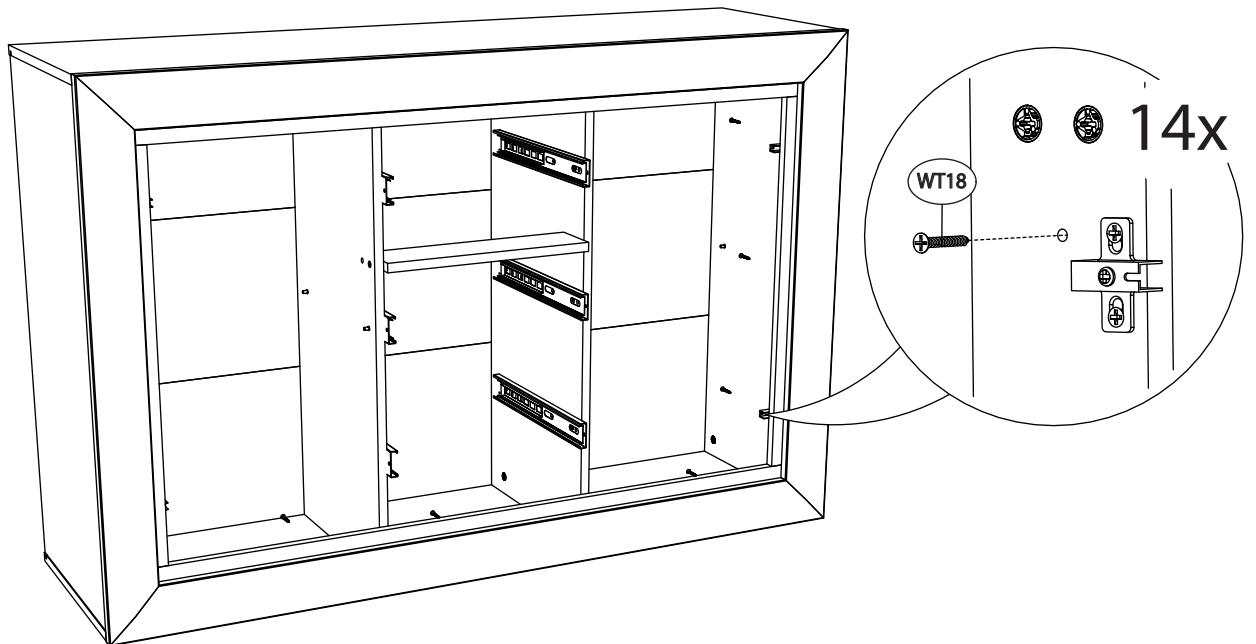

30.

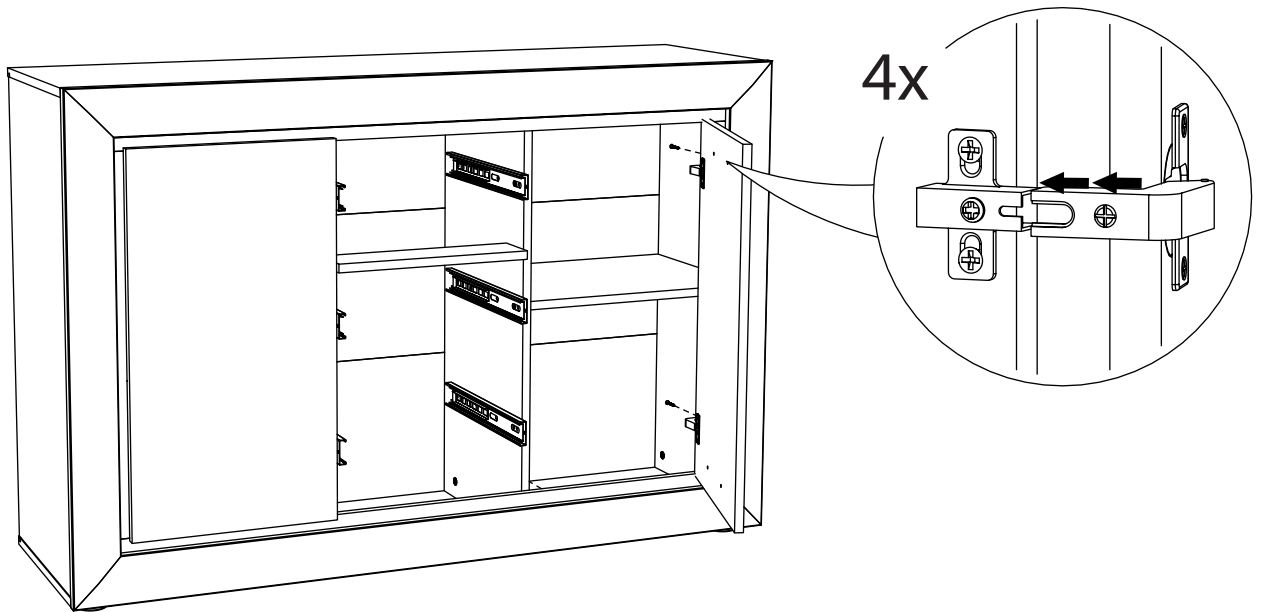
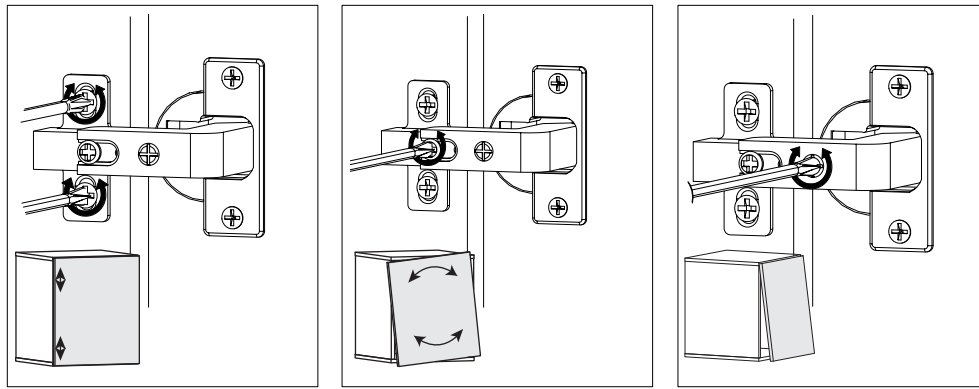

31.

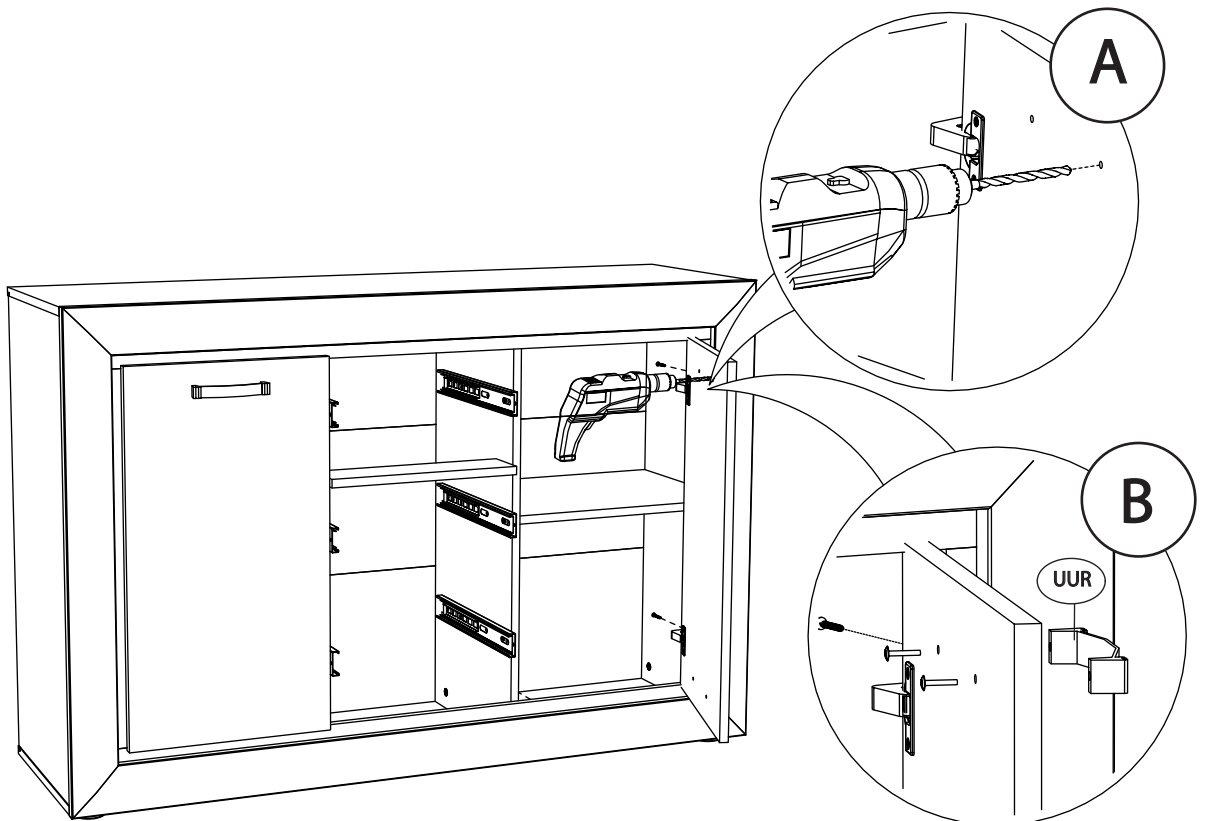

32.

x3

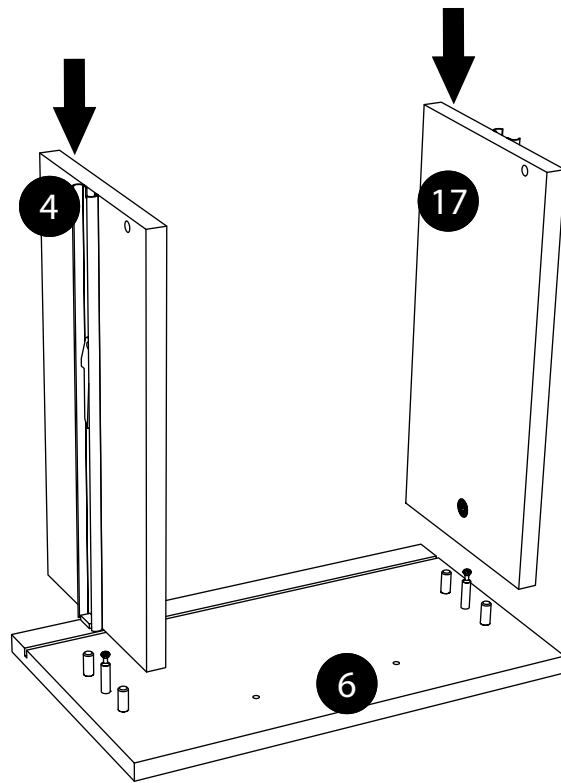

33.

x3

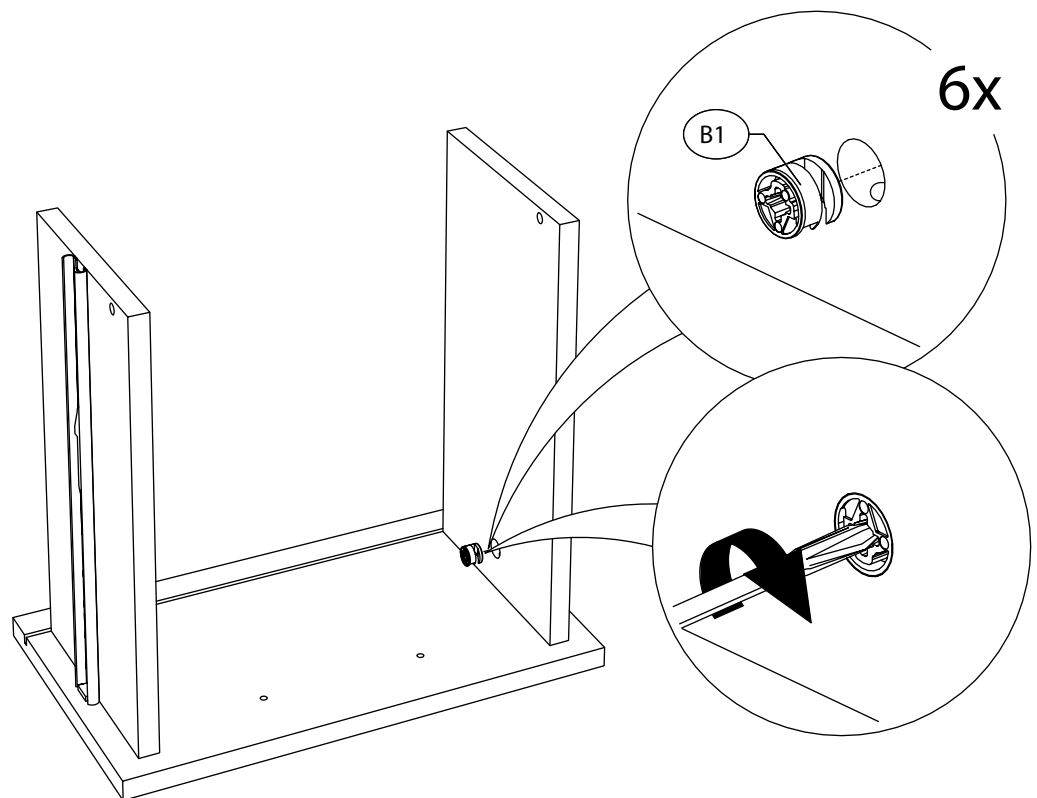

34.

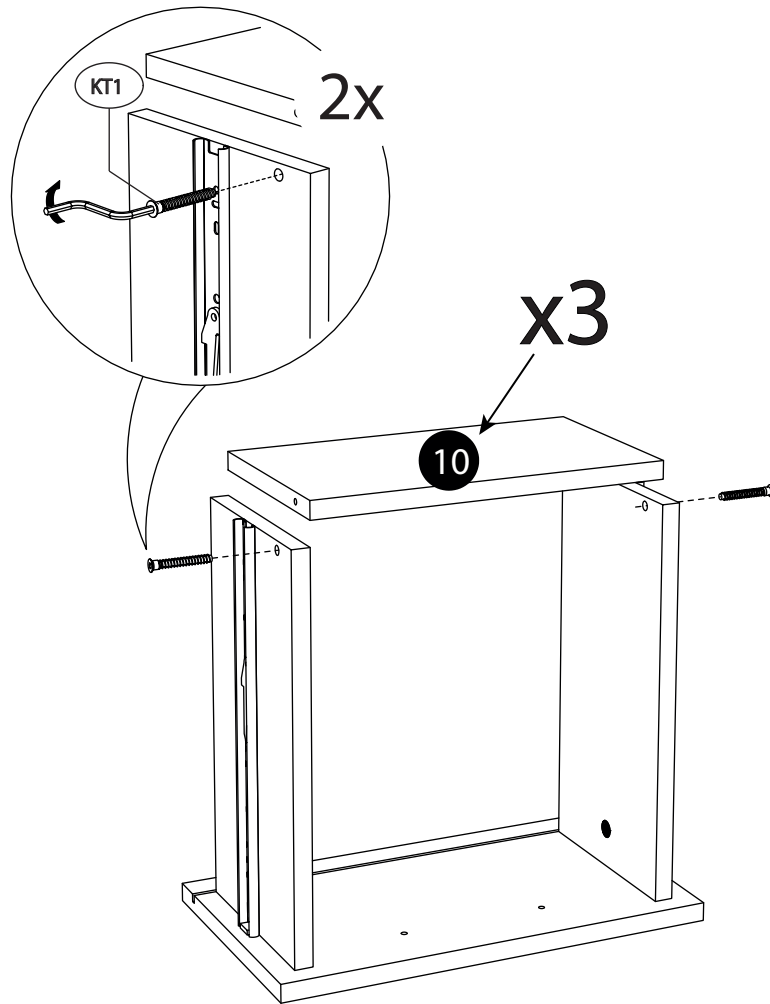

35.

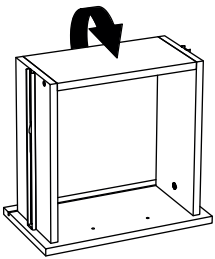

x3

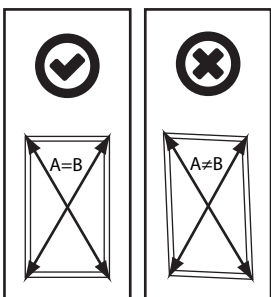
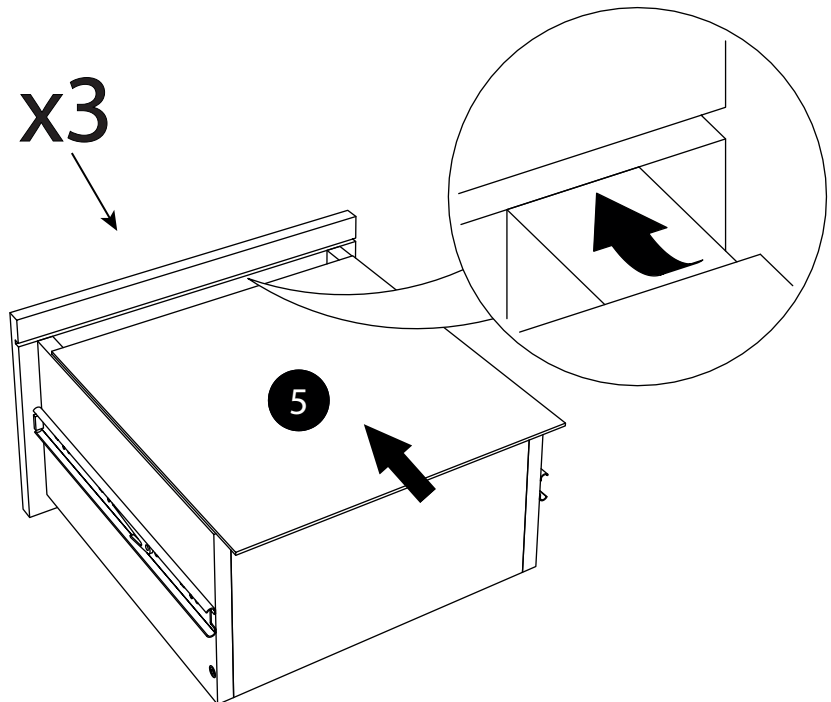

36.

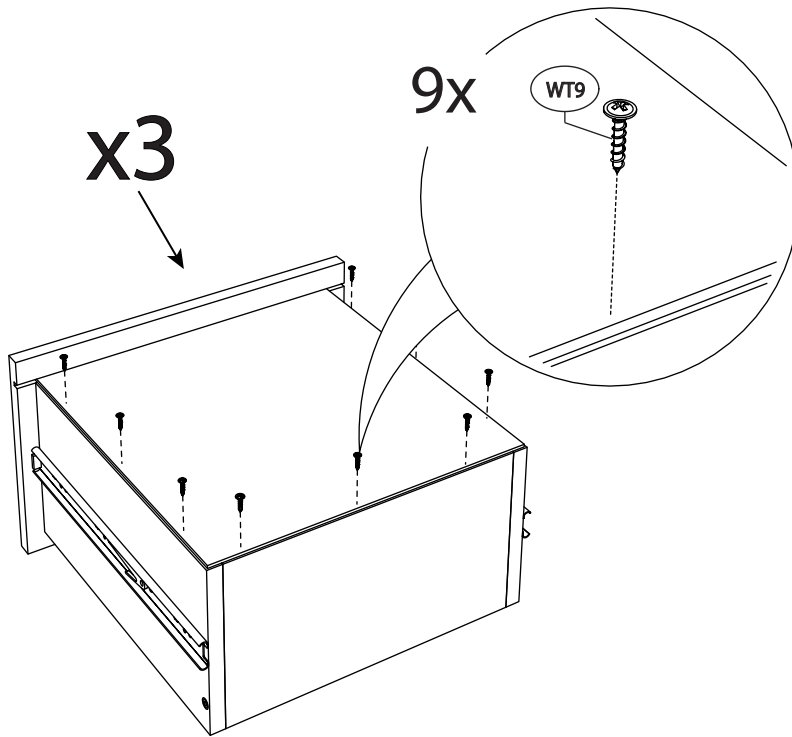

37.

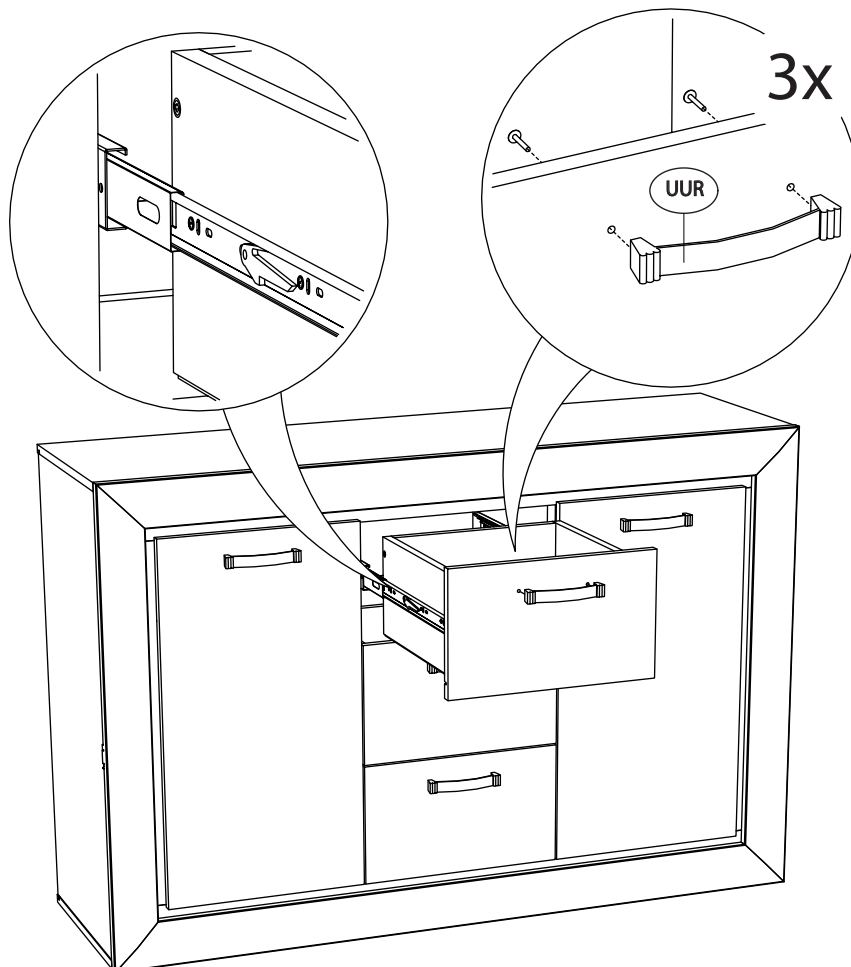

38.

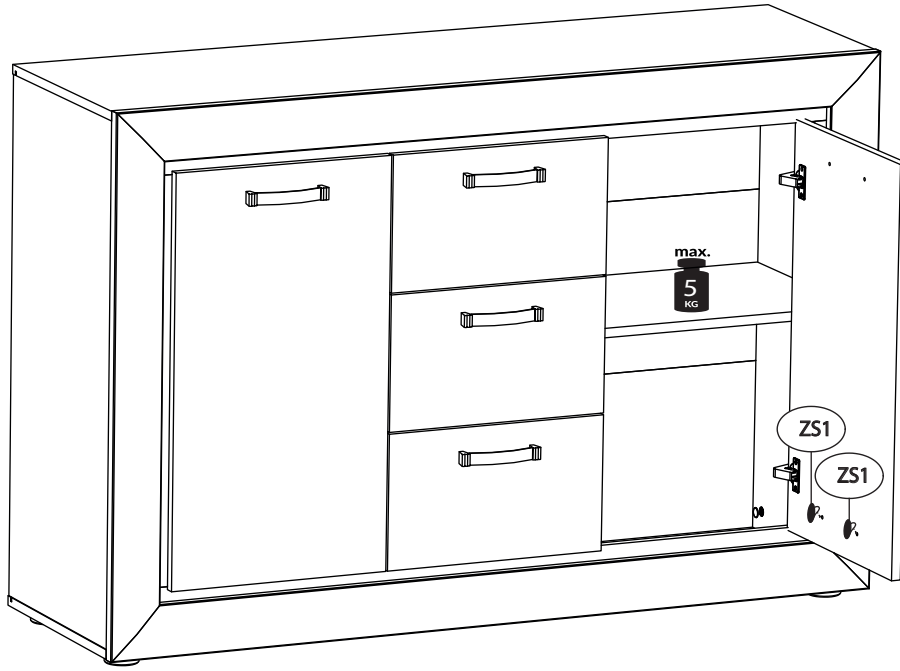

39.

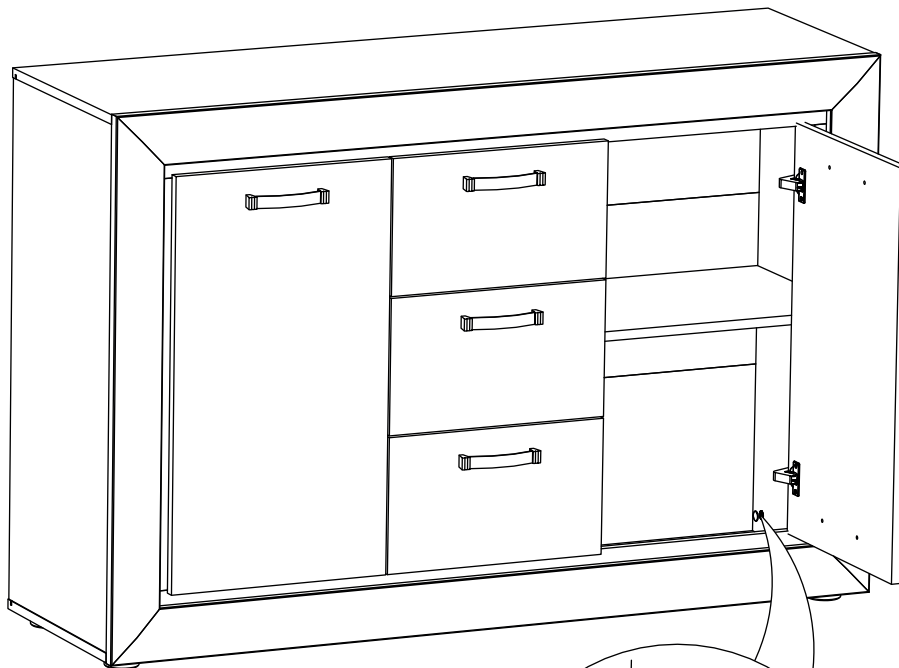

44x

