

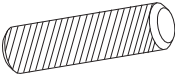

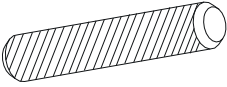

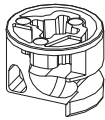

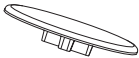

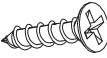

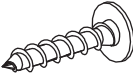







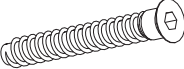
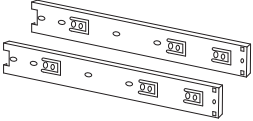
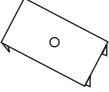
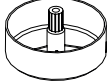

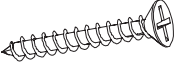
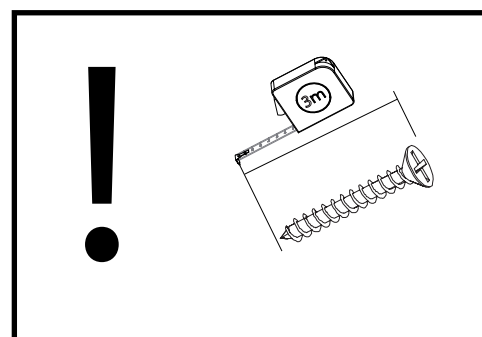
MOCCA 15

<p>K1 x 40 8x32</p> 	<p>K2 x 2 8x60</p> 	<p>B2 x 56 h-12</p> 
<p>ZM1 x 13 Ø18</p> 	<p>WT1 x 4 3,5x15</p> 	<p>ZD1 x 4 L68</p> 
<p>ZJ1 x 44 L-43</p> 	<p>WT9 x 36 3x16</p> 	<p>SP x 10</p> 
<p>UUR x 2 L-128</p>  	<p>WE7 x 12 6,3x13ES</p> 	<p>x 1</p> 
<p>WS1 x 2 L-350</p> 	<p>ZD2 x 2 L-76</p> 	<p>KT1 x 4 6,3x50</p> 
<p>P1 x 2 L-350</p> 	<p>BR1 x 10</p> 	<p>SMO x 5 Ø50 h25</p> 
<p>GW1 x 15 1,4x25</p> 	<p>WT18 x 10 4x30</p> 	

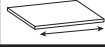

MOCCA 15

	CODE				
1	Mocca15_03	510	400	1	1/3
2	Mocca15_04	510	400	1	1/3
3	Mocca15_12	124	350	2	1/3
4	Mocca15HDF_01	67	355	2	2/3
5	Mocca15_10	715	172	1	1/3
6	Mocca15_19	1648	88	2	3/3
7	Mocca15_15	1612	92	2	2/3
8	Mocca15_14	124	64	2	2/3
9	Mocca15_18	544	88	2	3/3
10	Mocca15_13	124	350	2	1/3

	CODE				
11	Mocca15_16	325	92	1	2/3
12	Mocca15_17	325	92	1	2/3
13	Mocca15_07	250	369	1	1/3
14	Mocca15_06	244	369	1	1/3
15	Mocca15_05	1613	385	1	2/3
16	Mocca15HDF_02	1623	263	1	2/3
17	Mocca15HDF_03	1623	257	1	2/3
18	Mocca15_02	1648	400	1	2/3
19	Mocca15_08	250	300	1	1/3
20	Mocca15_01	1648	400	1	2/3
21	Mocca15_09	250	300	1	1/3
22	Mocca15_11	714	172	1	1/3

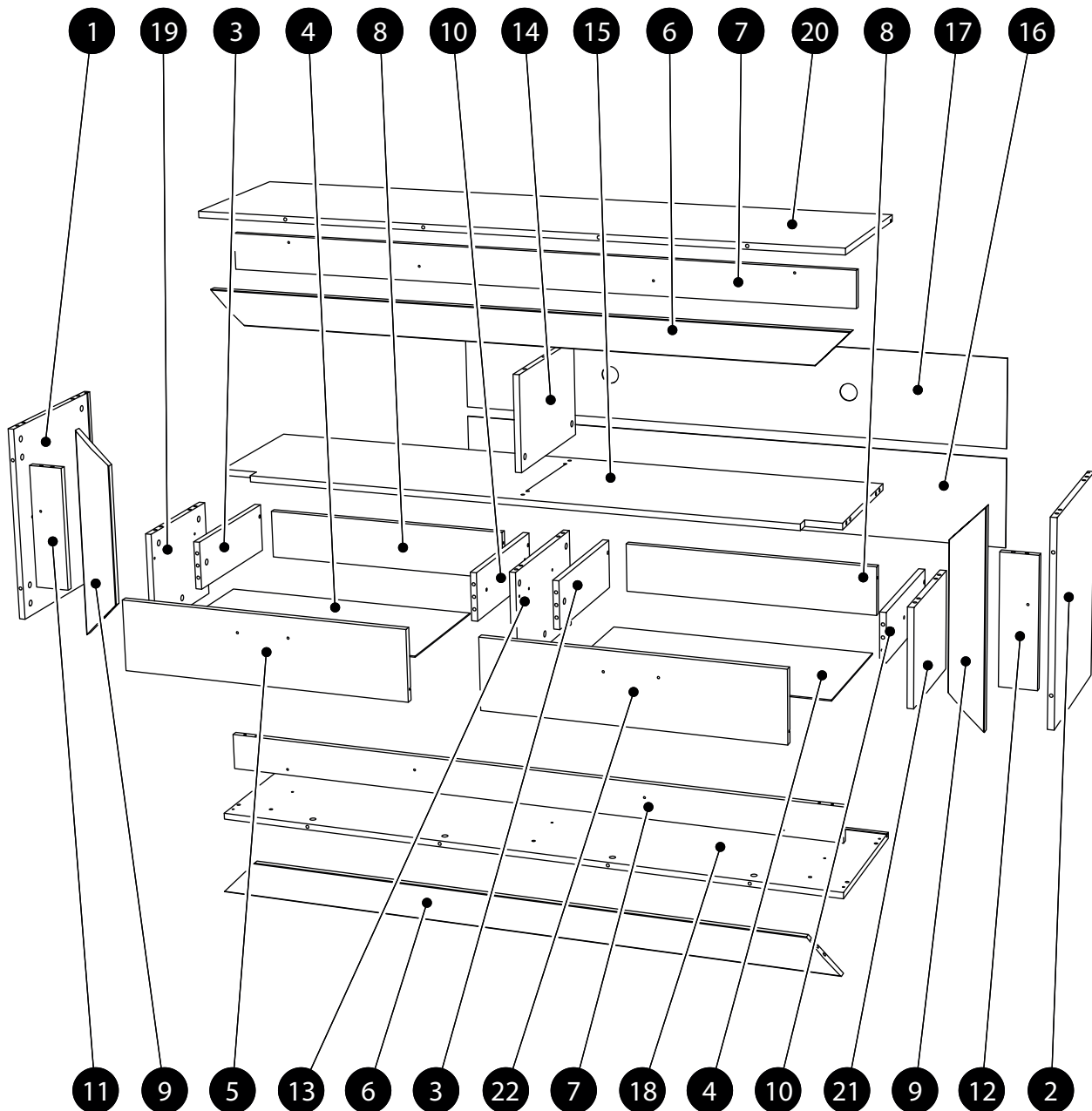

1.

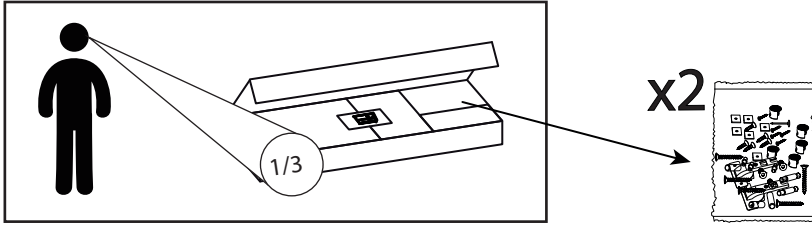

2a.

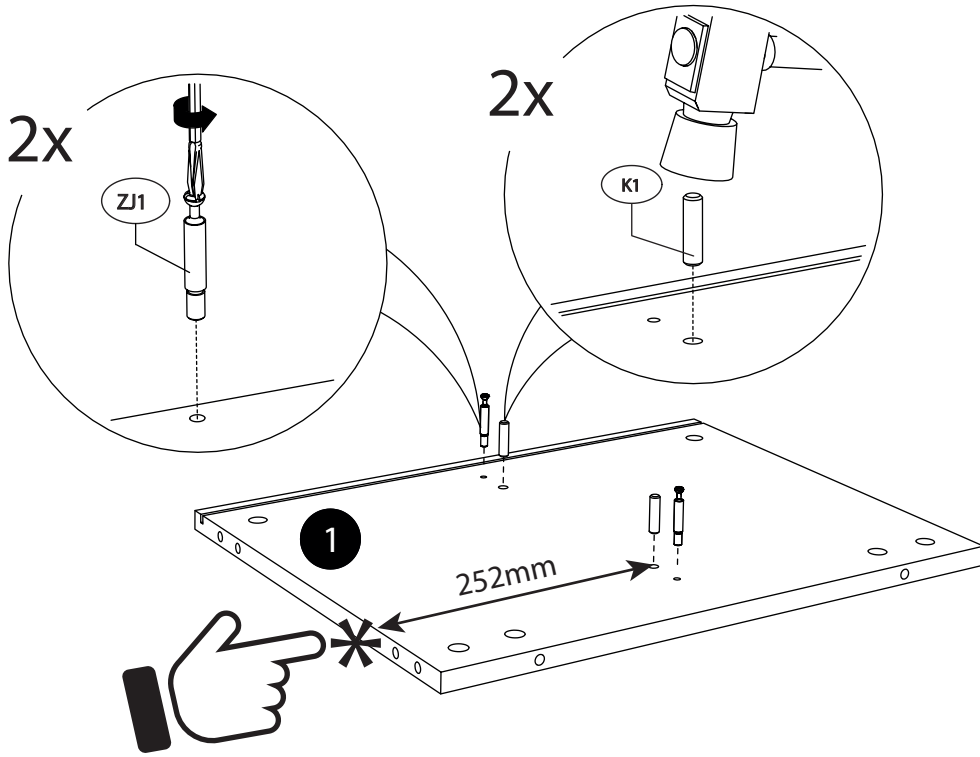

2b.

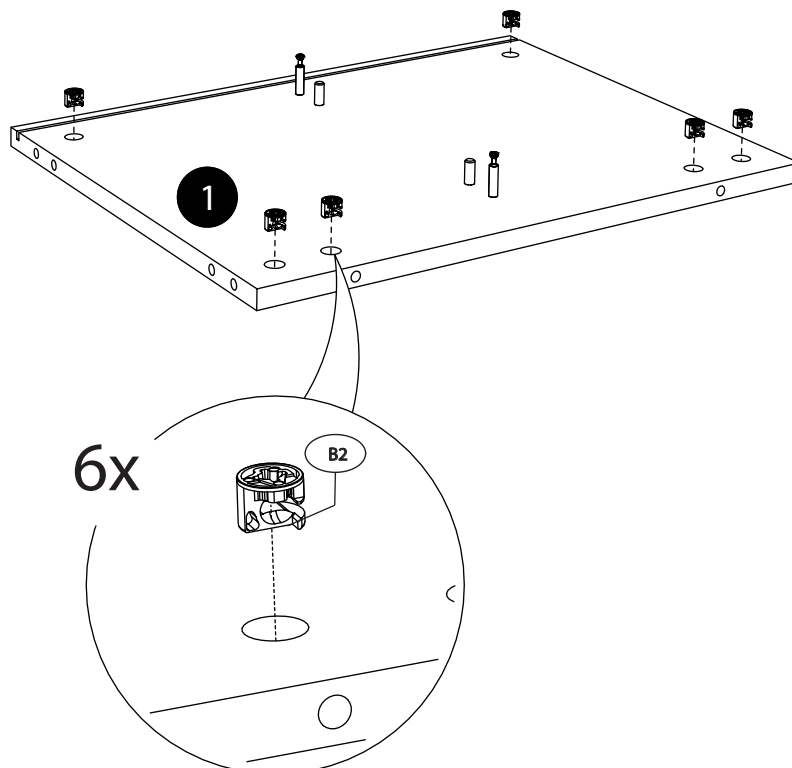

3.

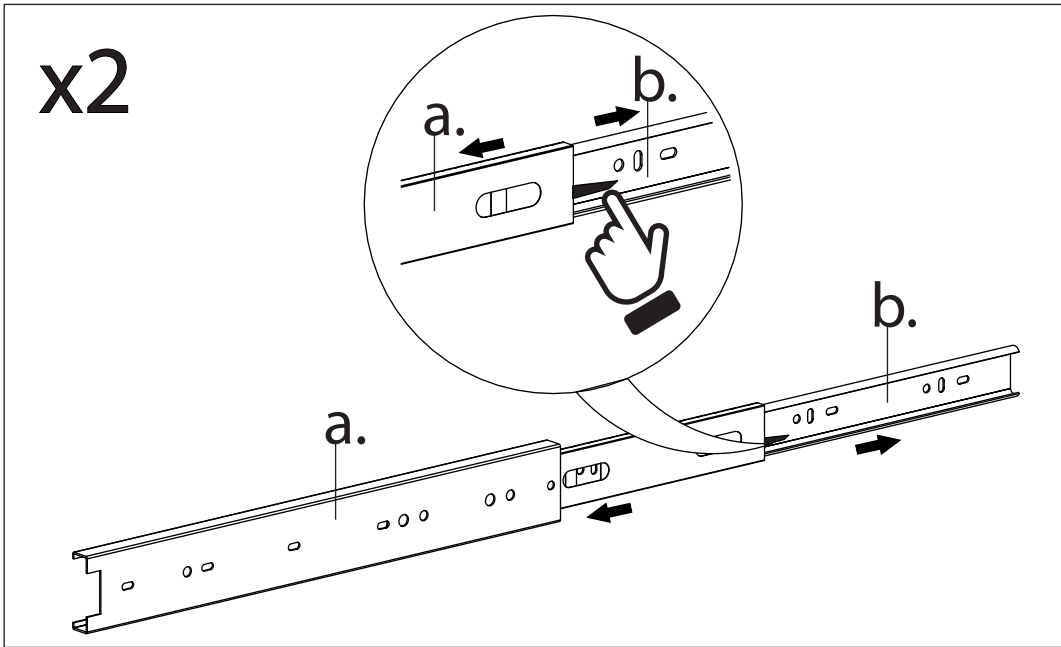

4.

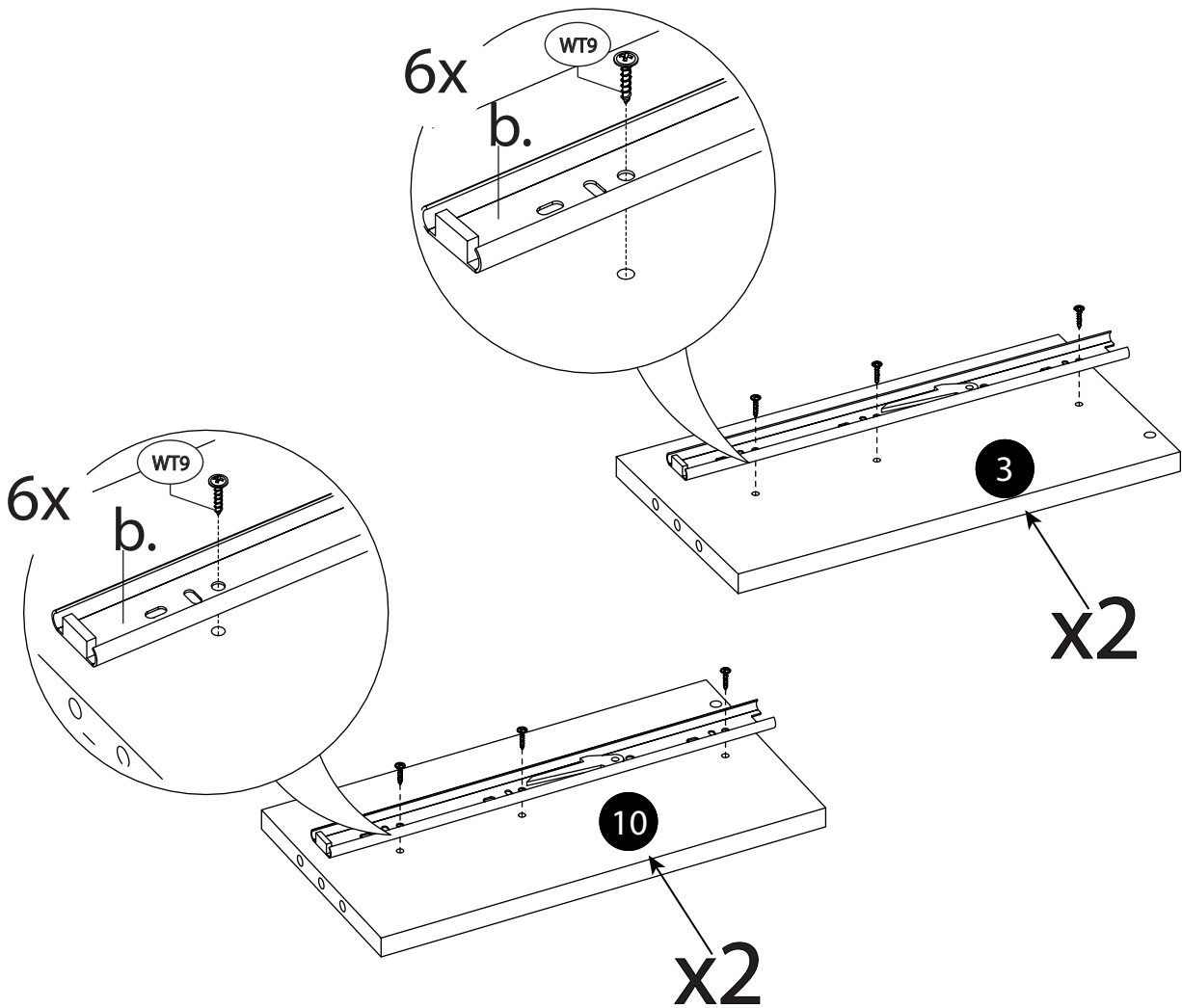

5.

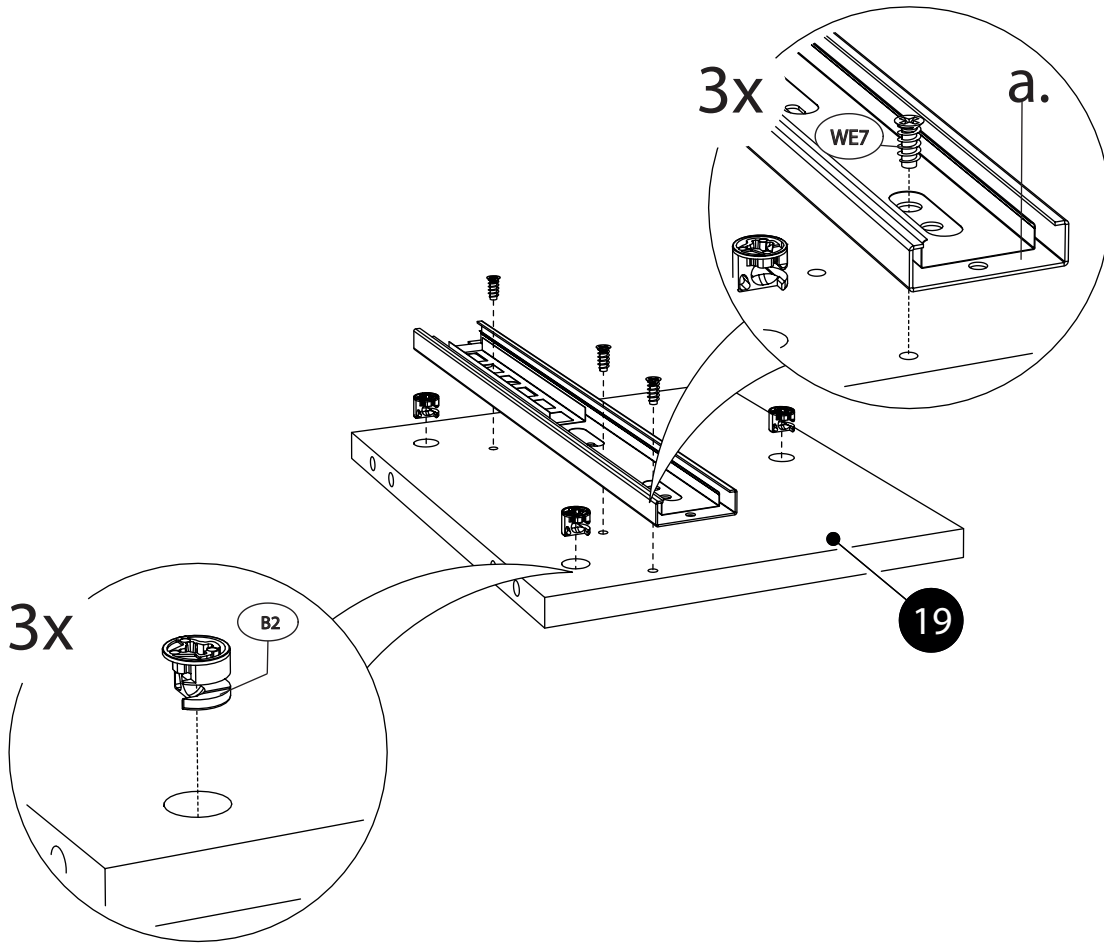

6.

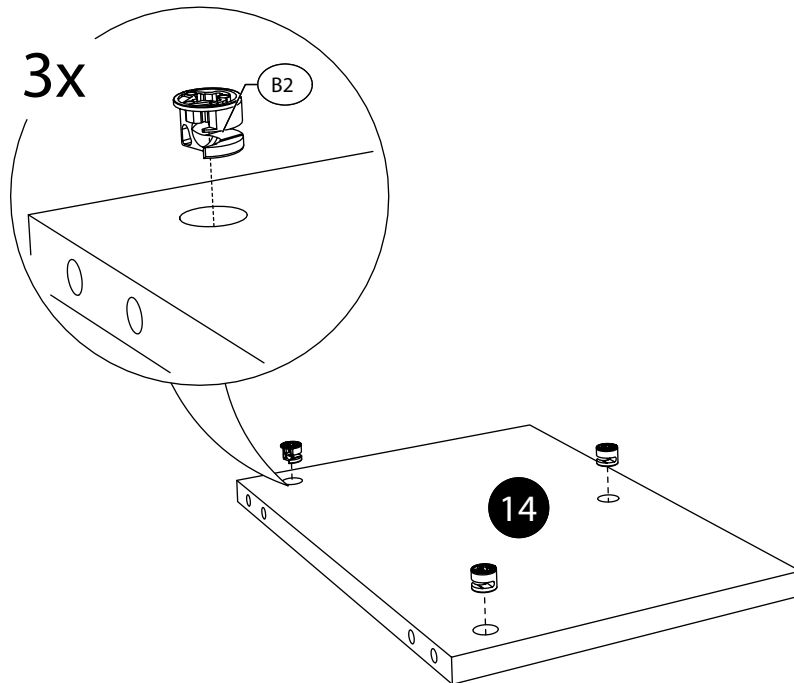

7.

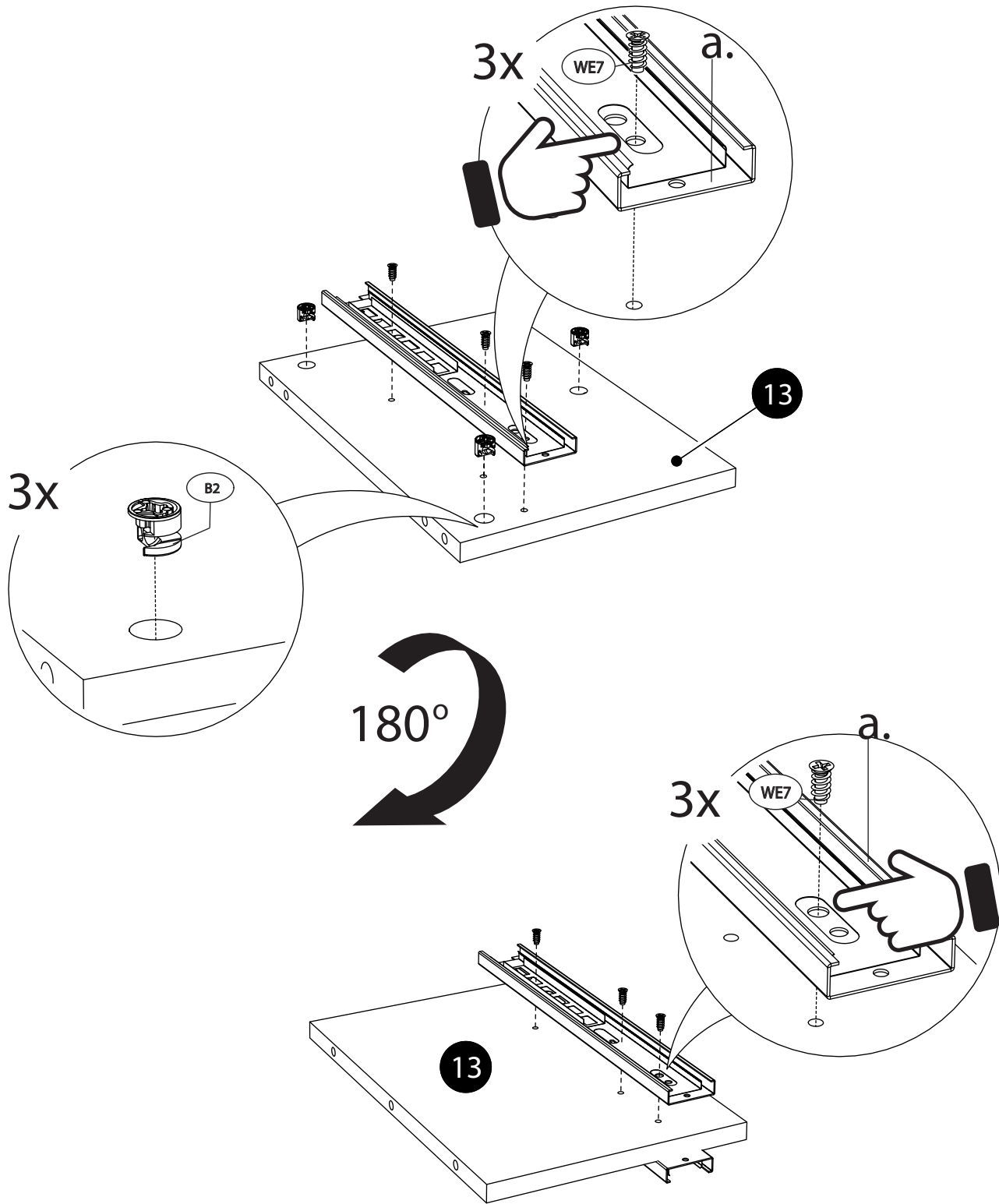

8.

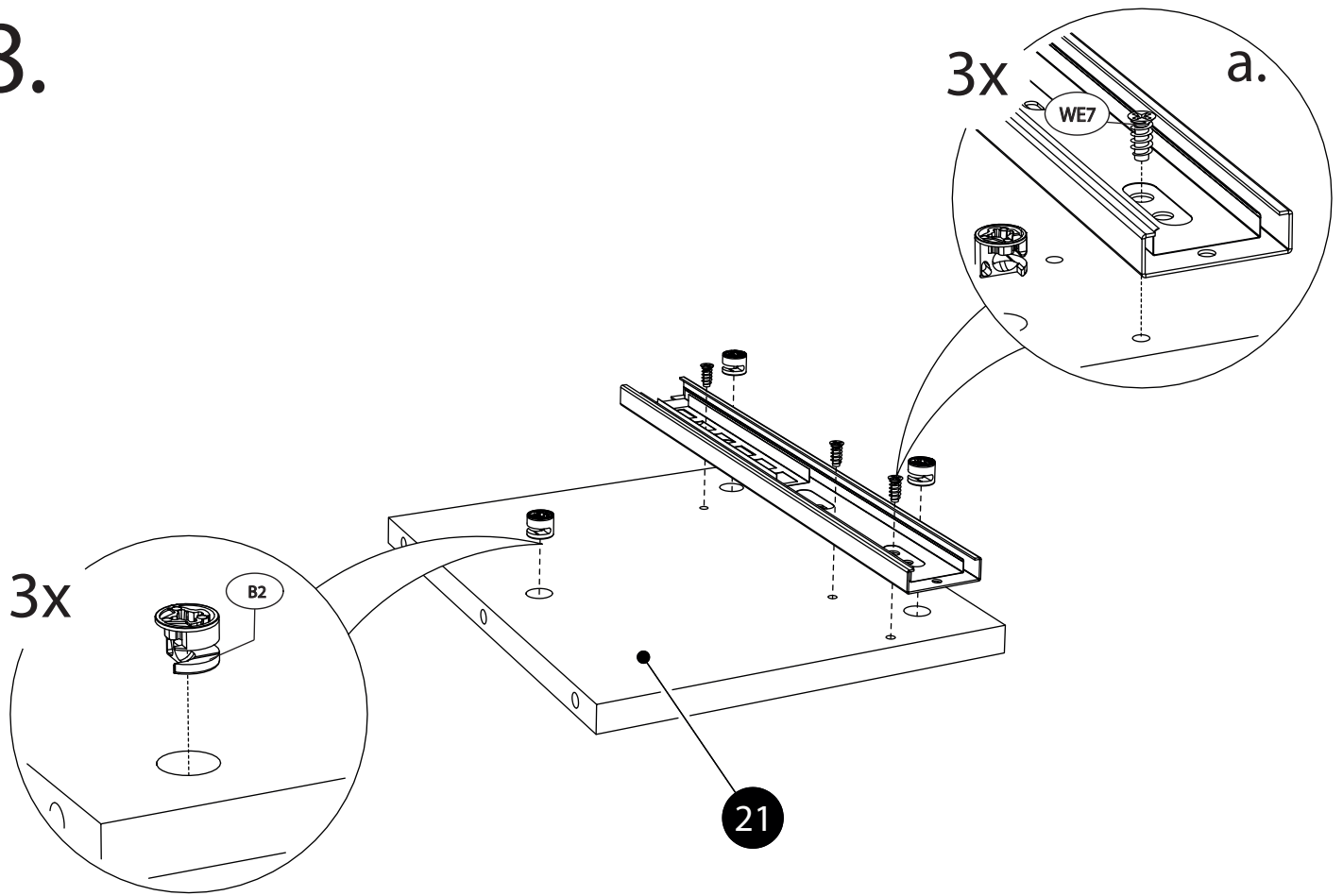

9a.

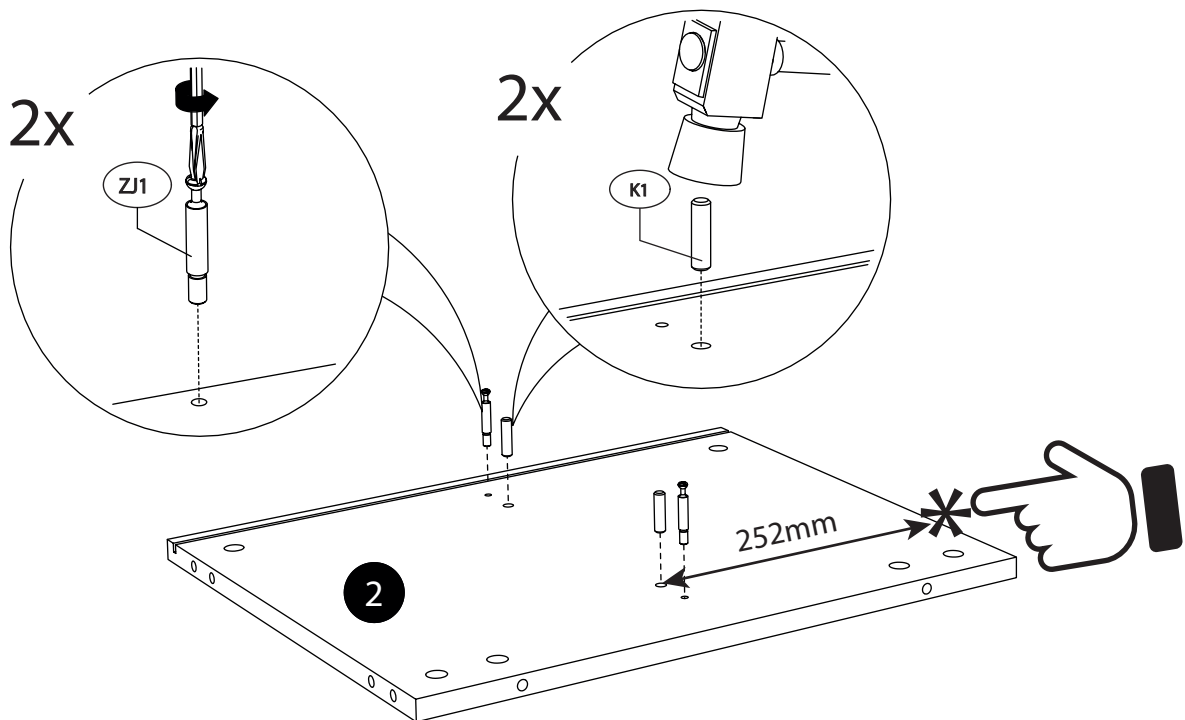

9b.

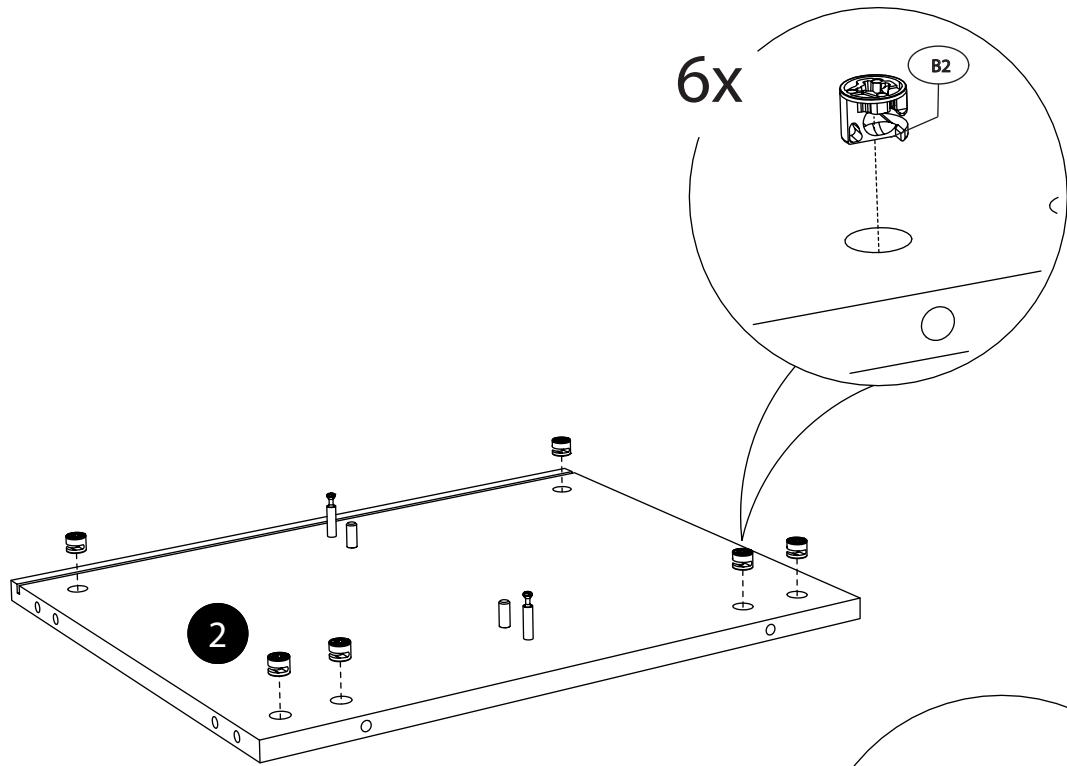

10.

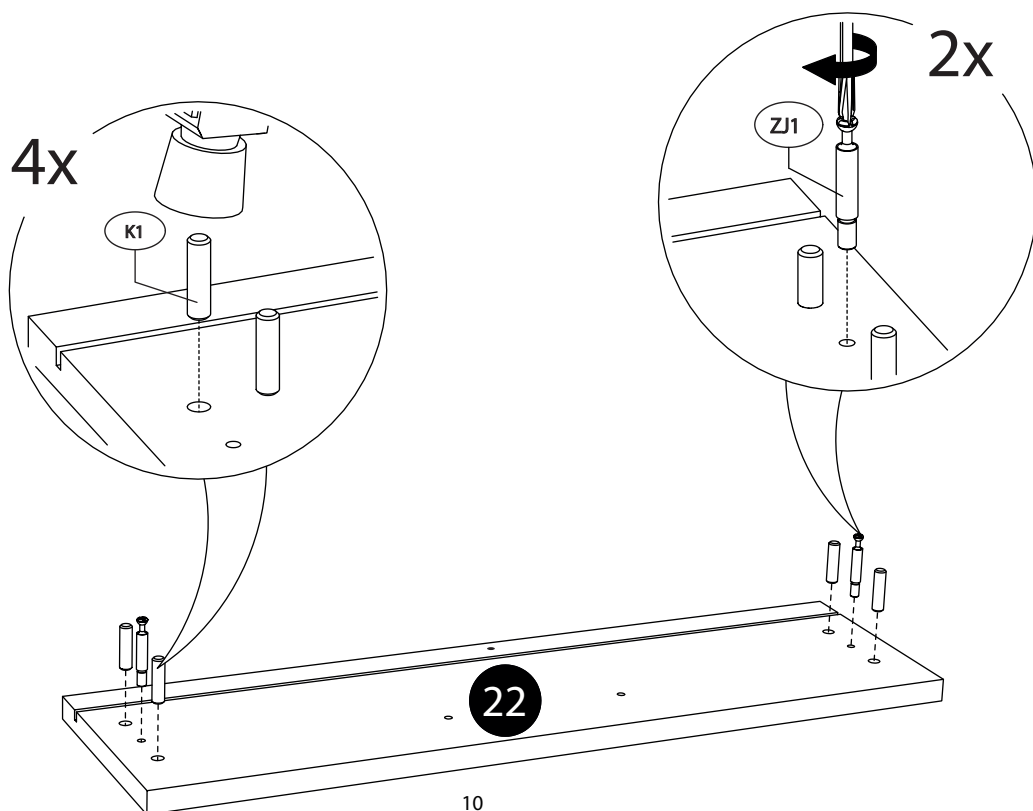
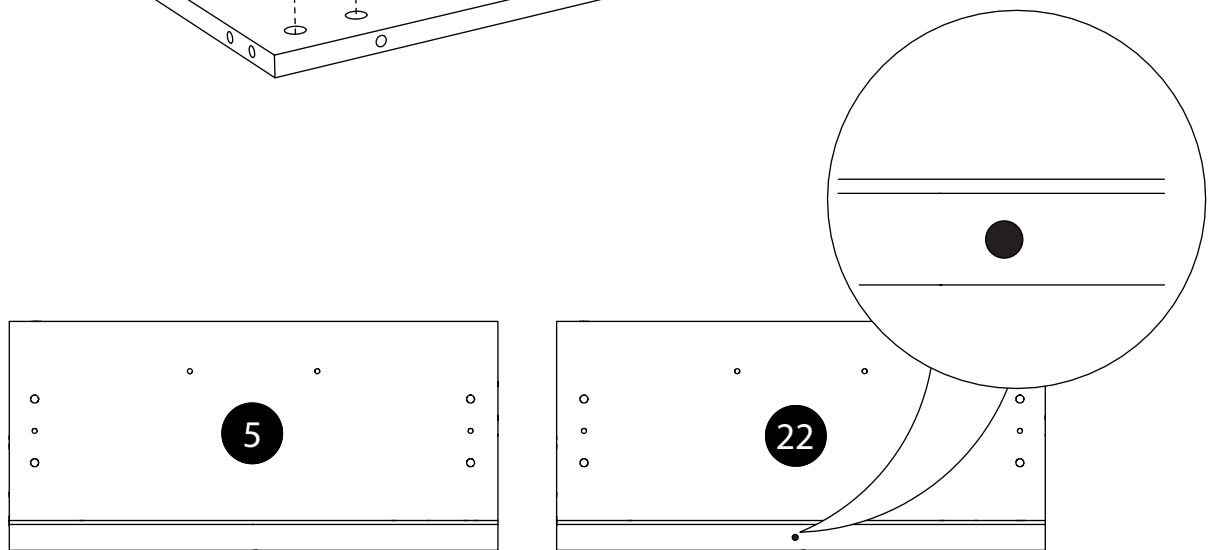

11.

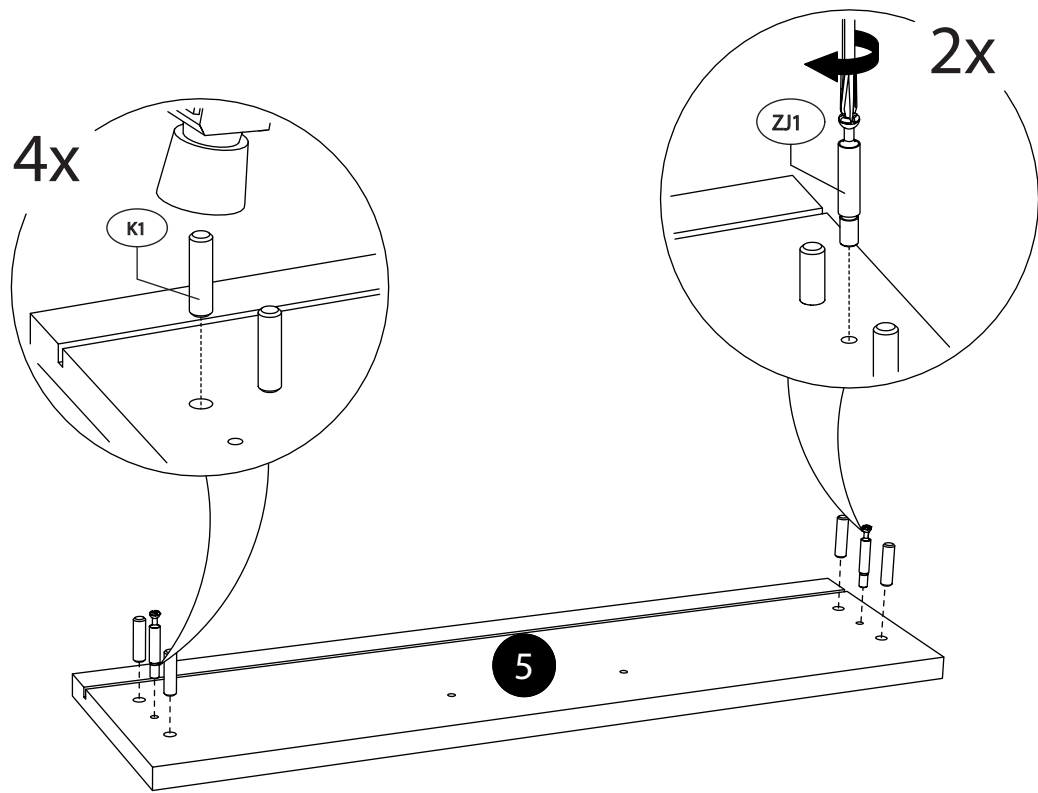

12.

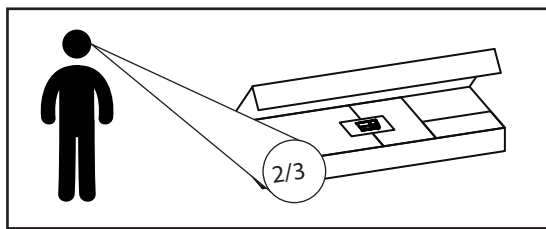

13a.

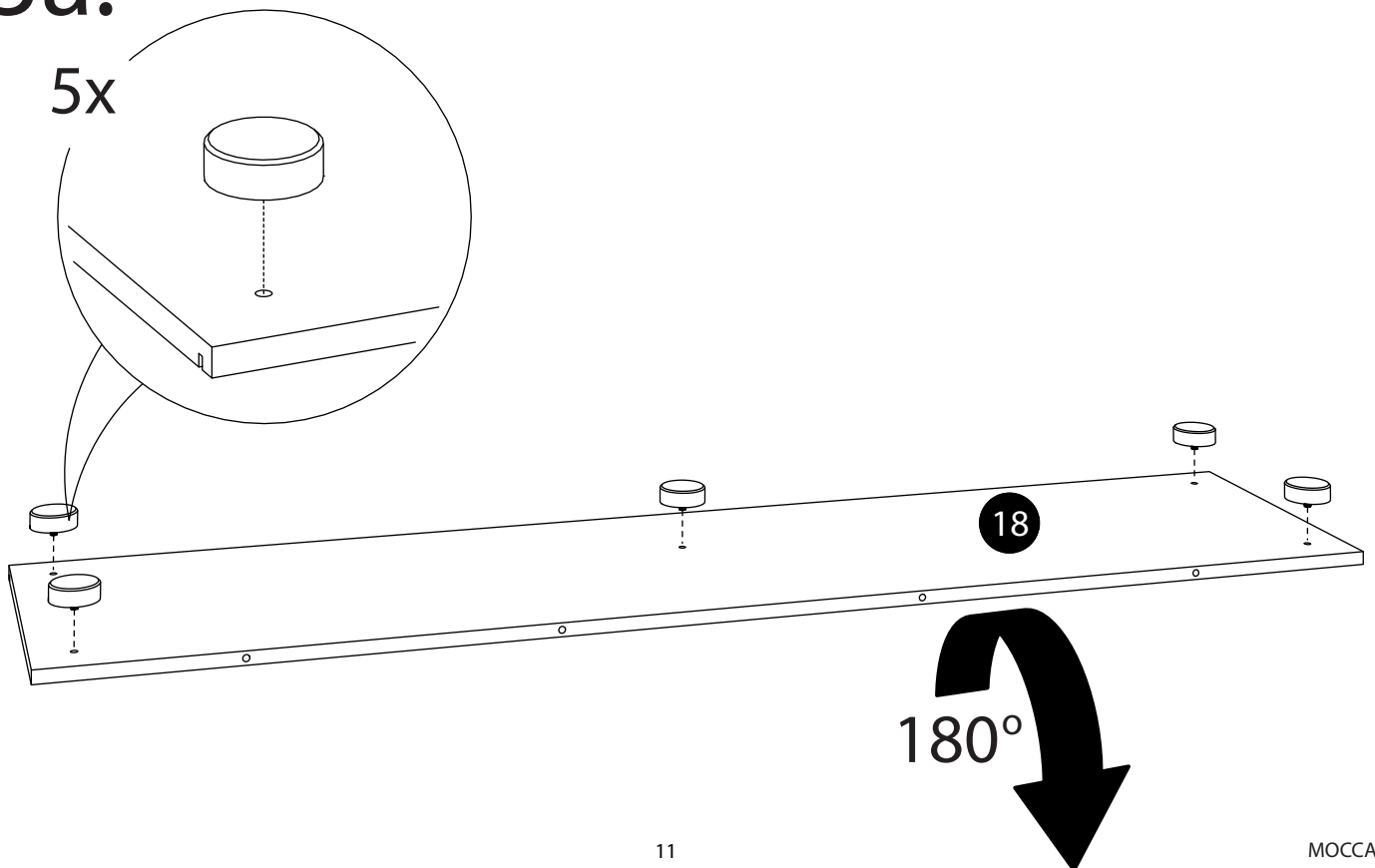

13b.

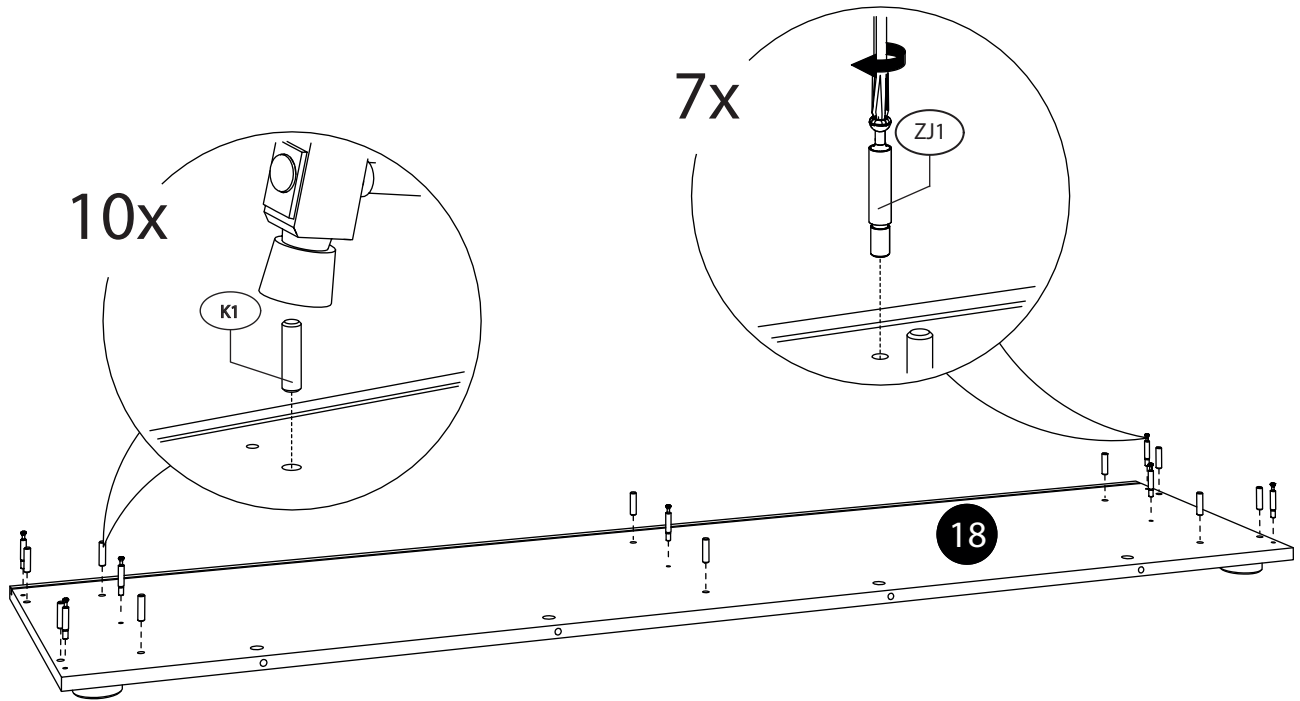

13c.

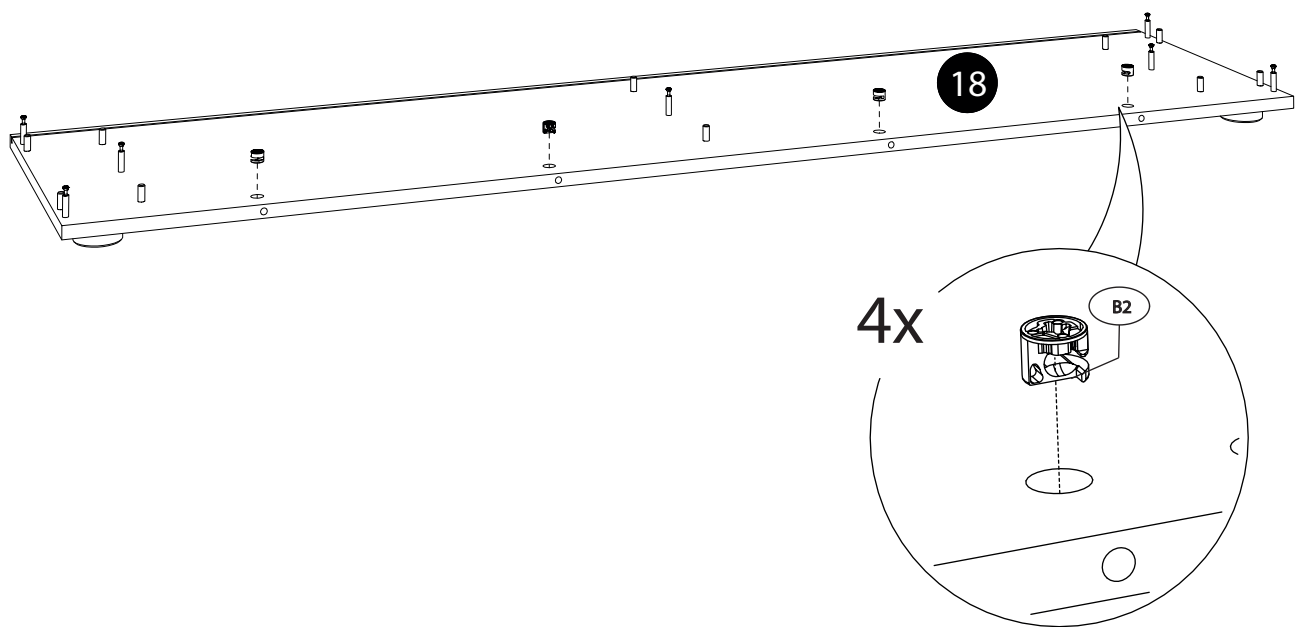

14.

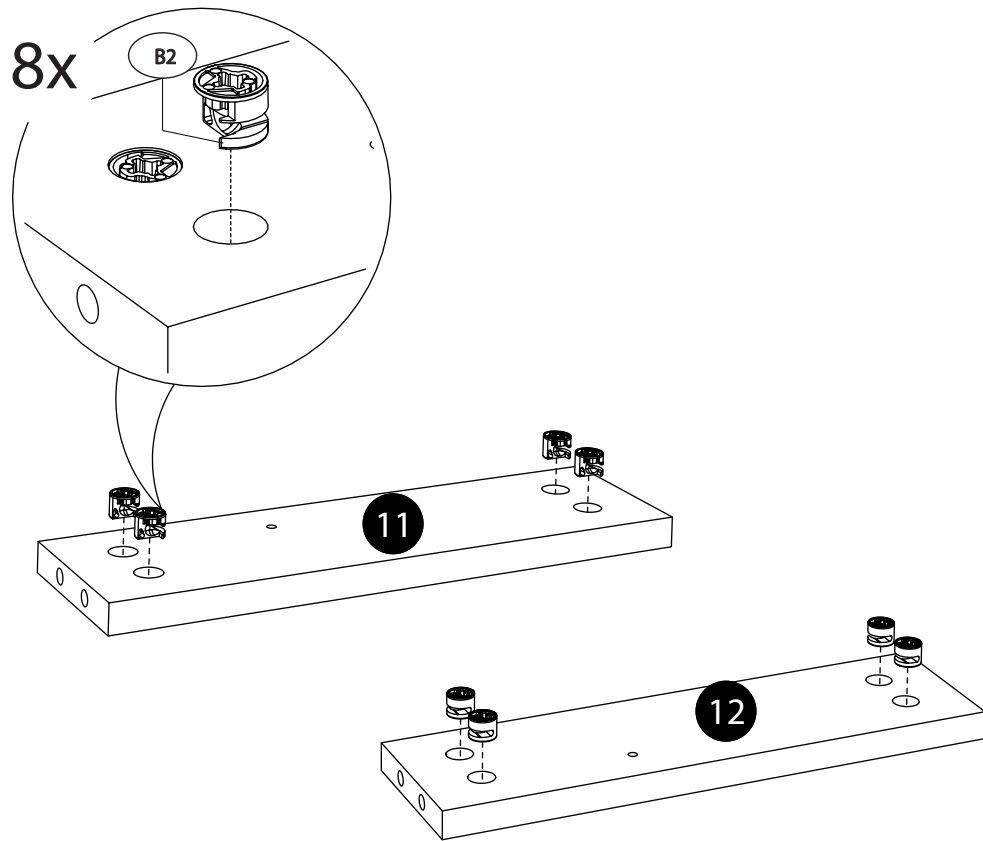

15.

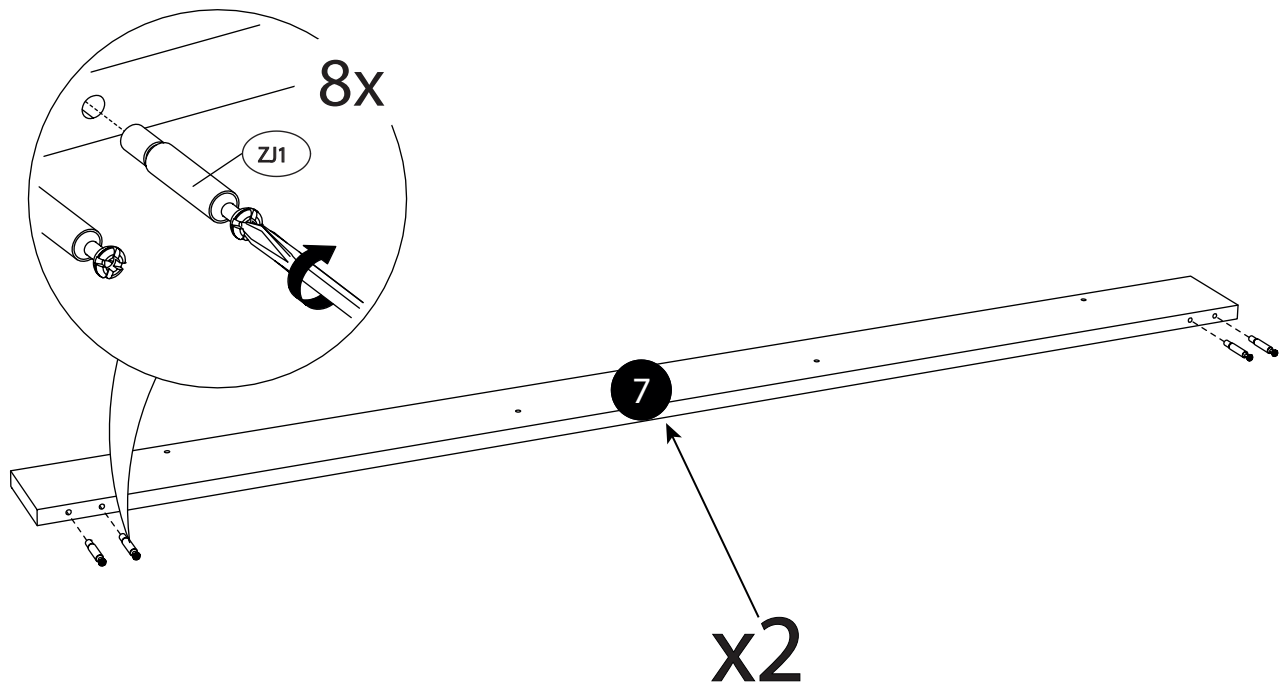

16a.

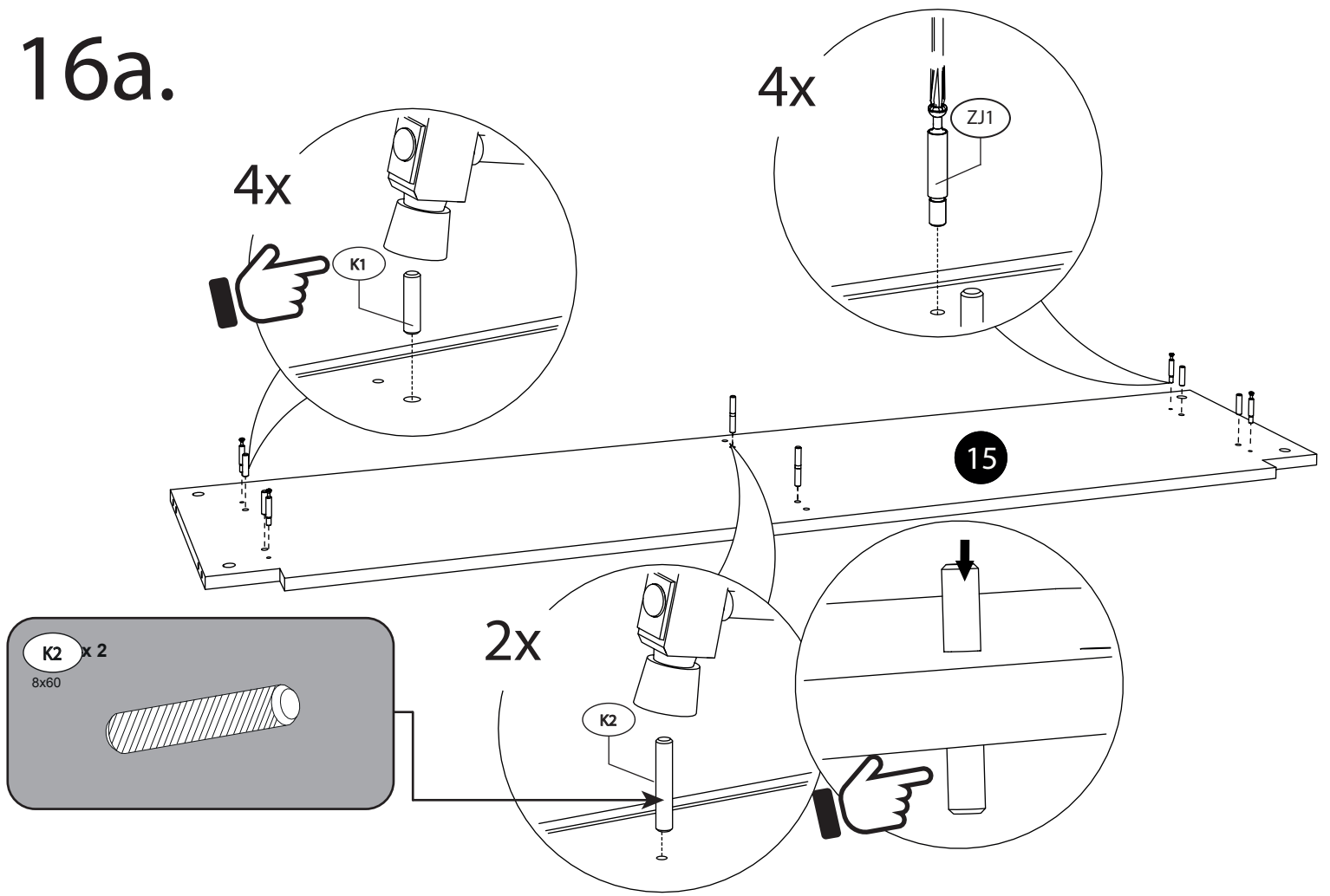

16b.

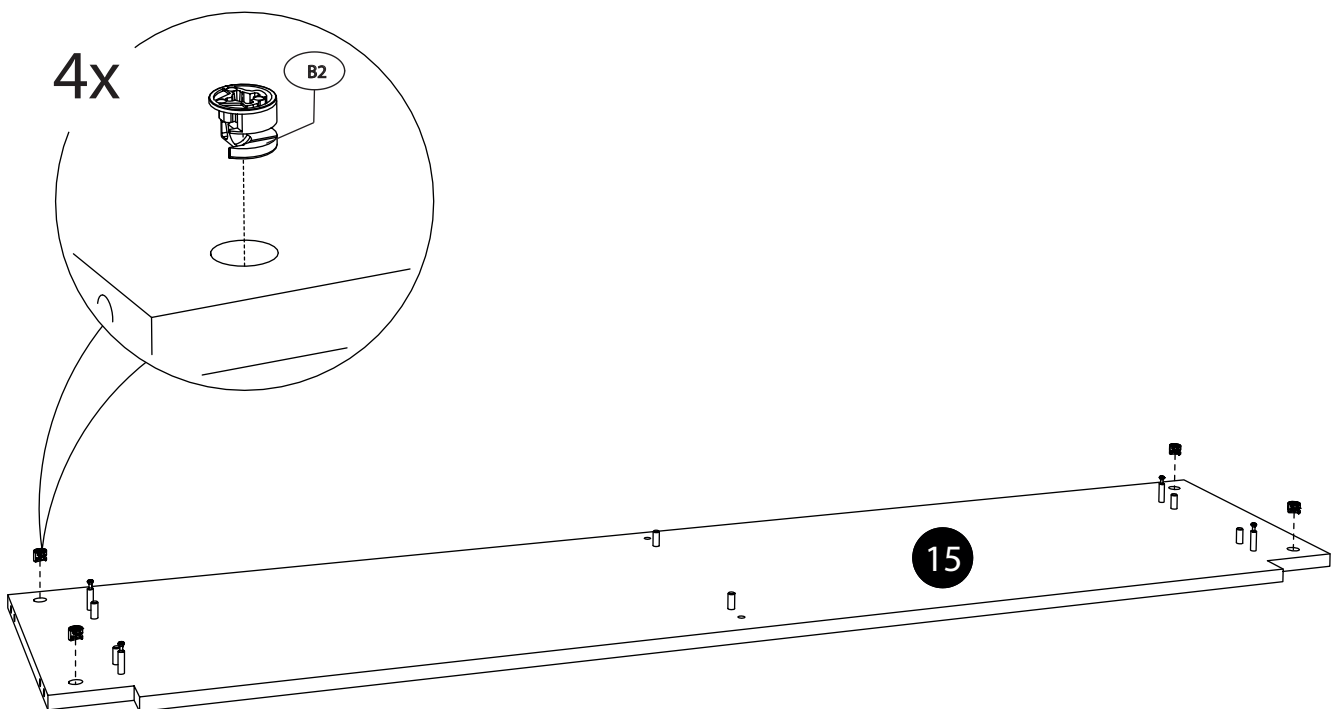

17a.

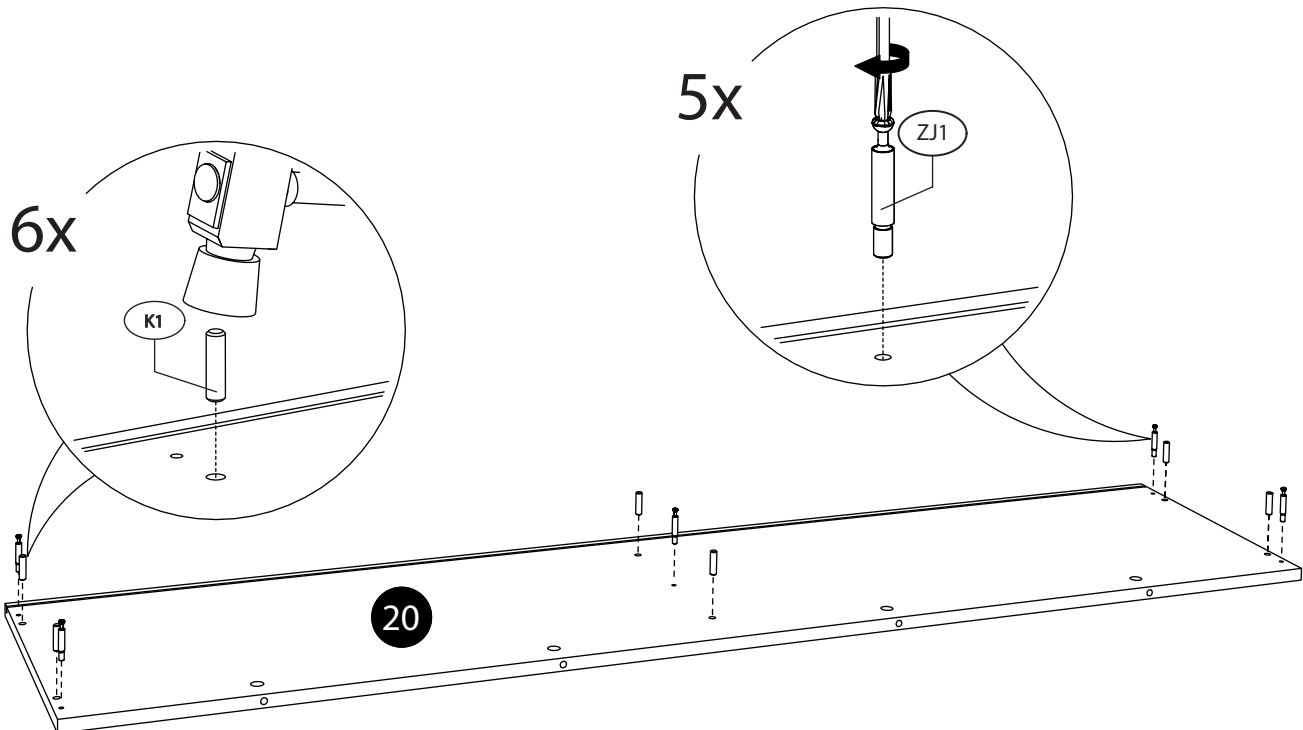

17b.

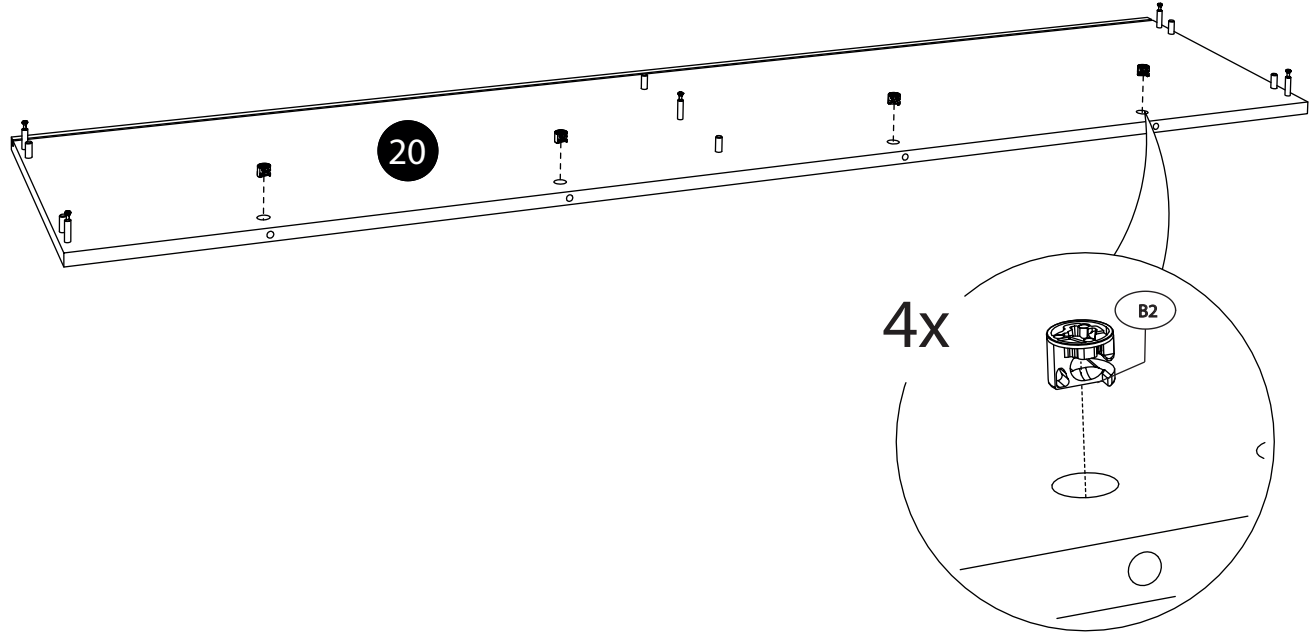

16.

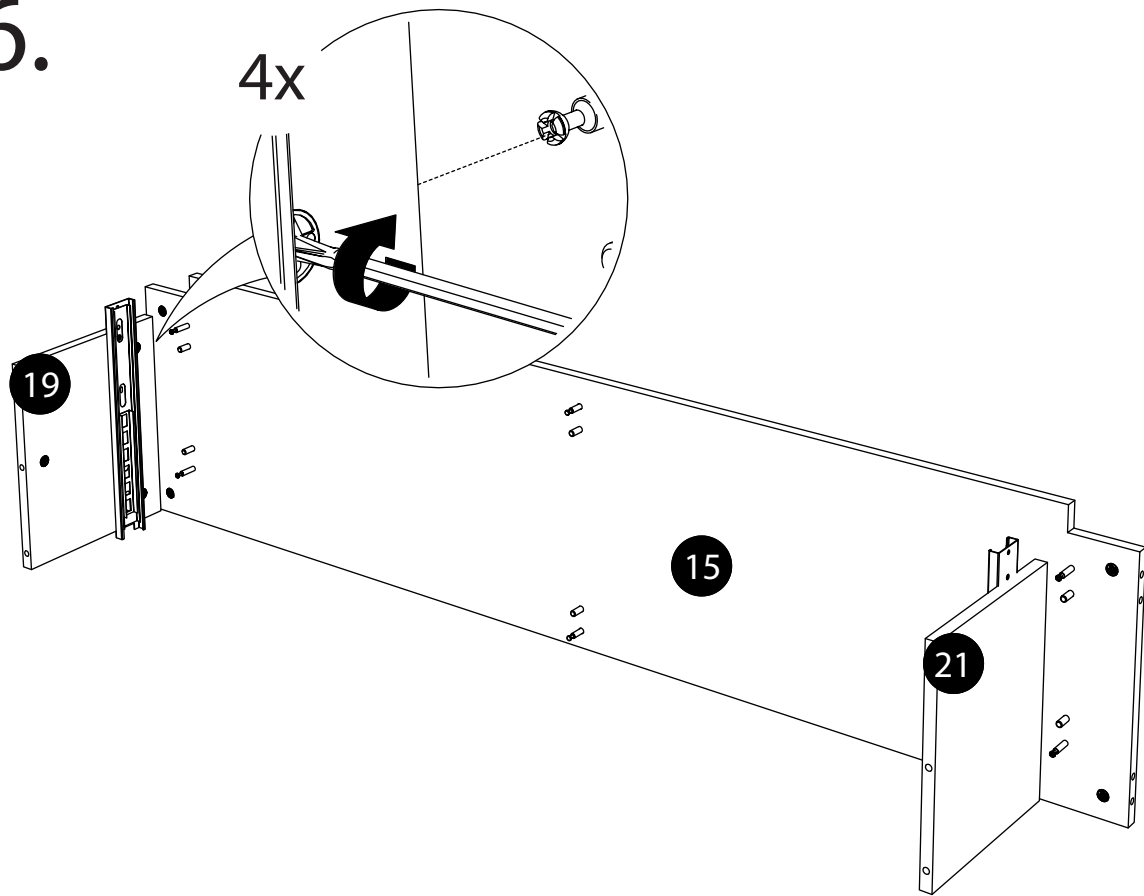

17.

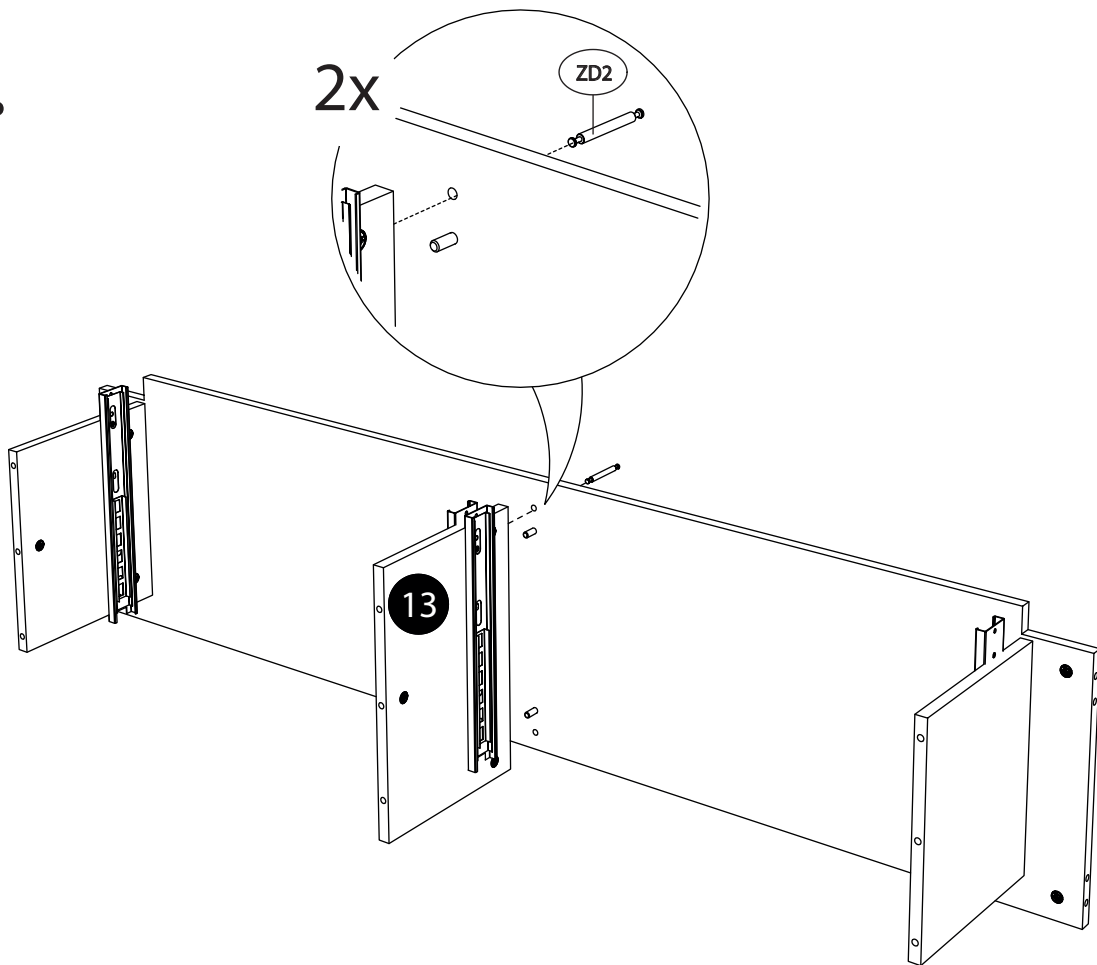

18.

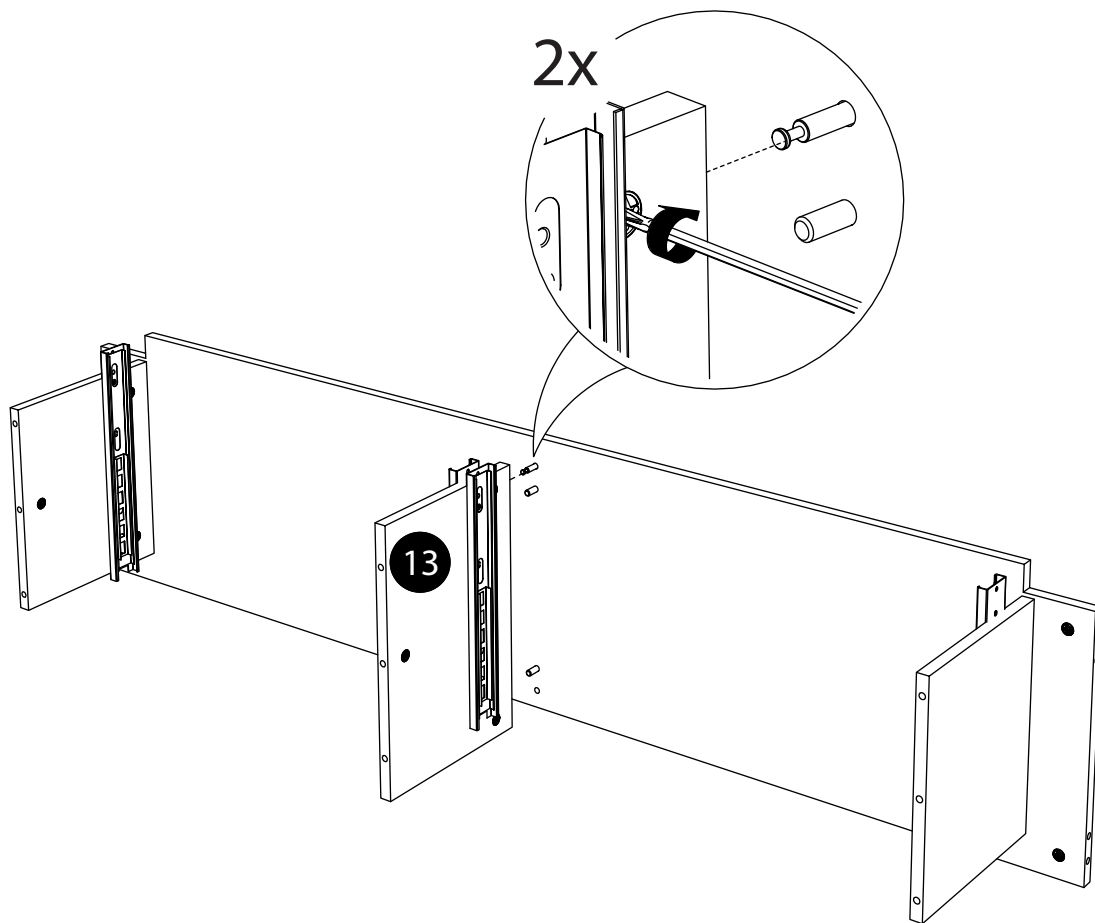

19.

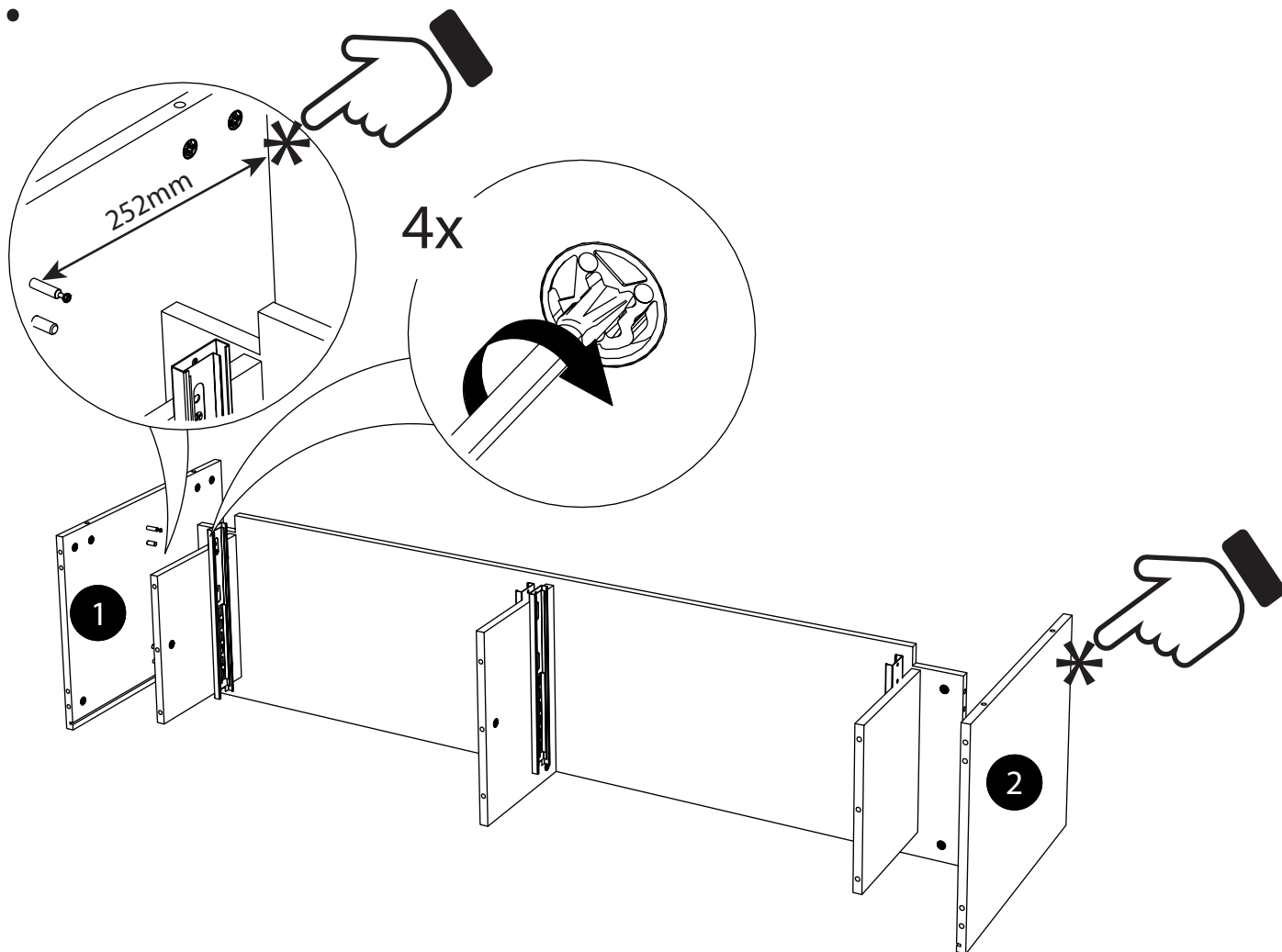

20.

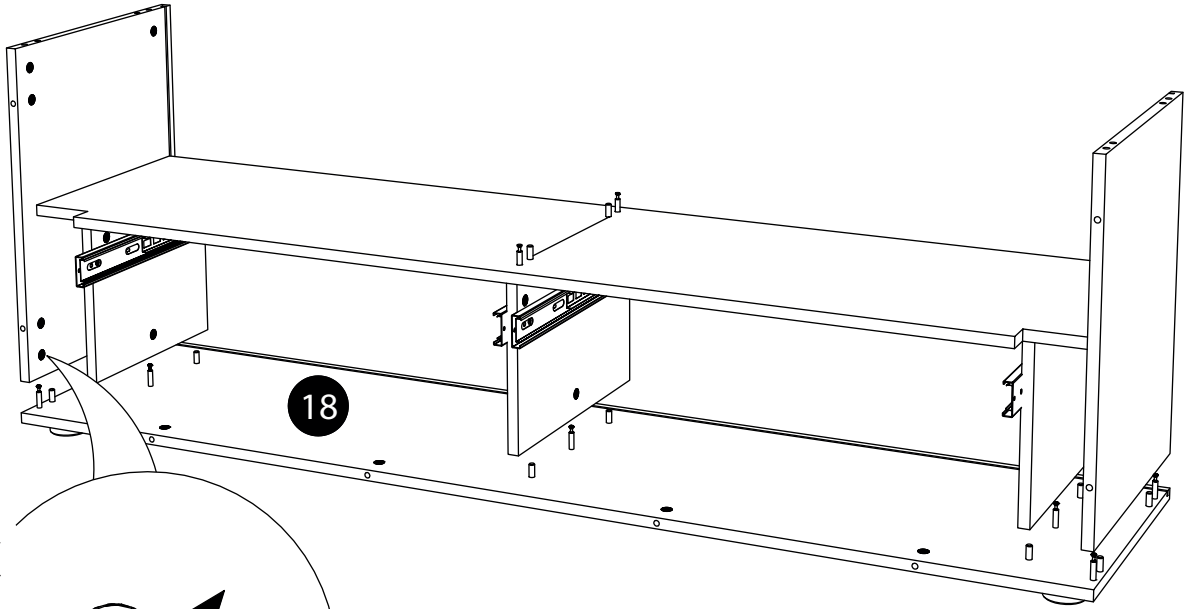
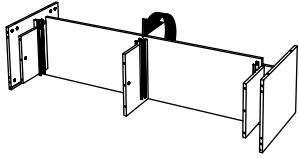

7x

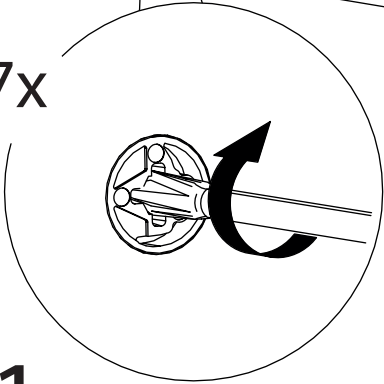

21.

2x

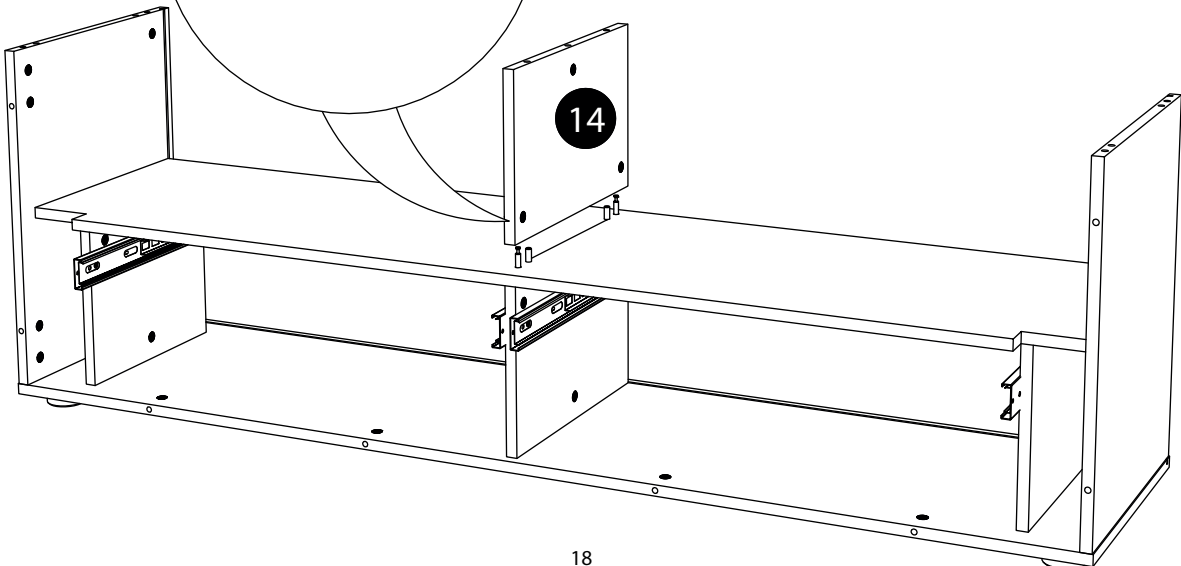
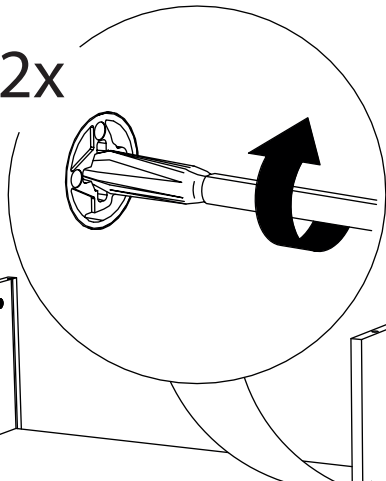

22.

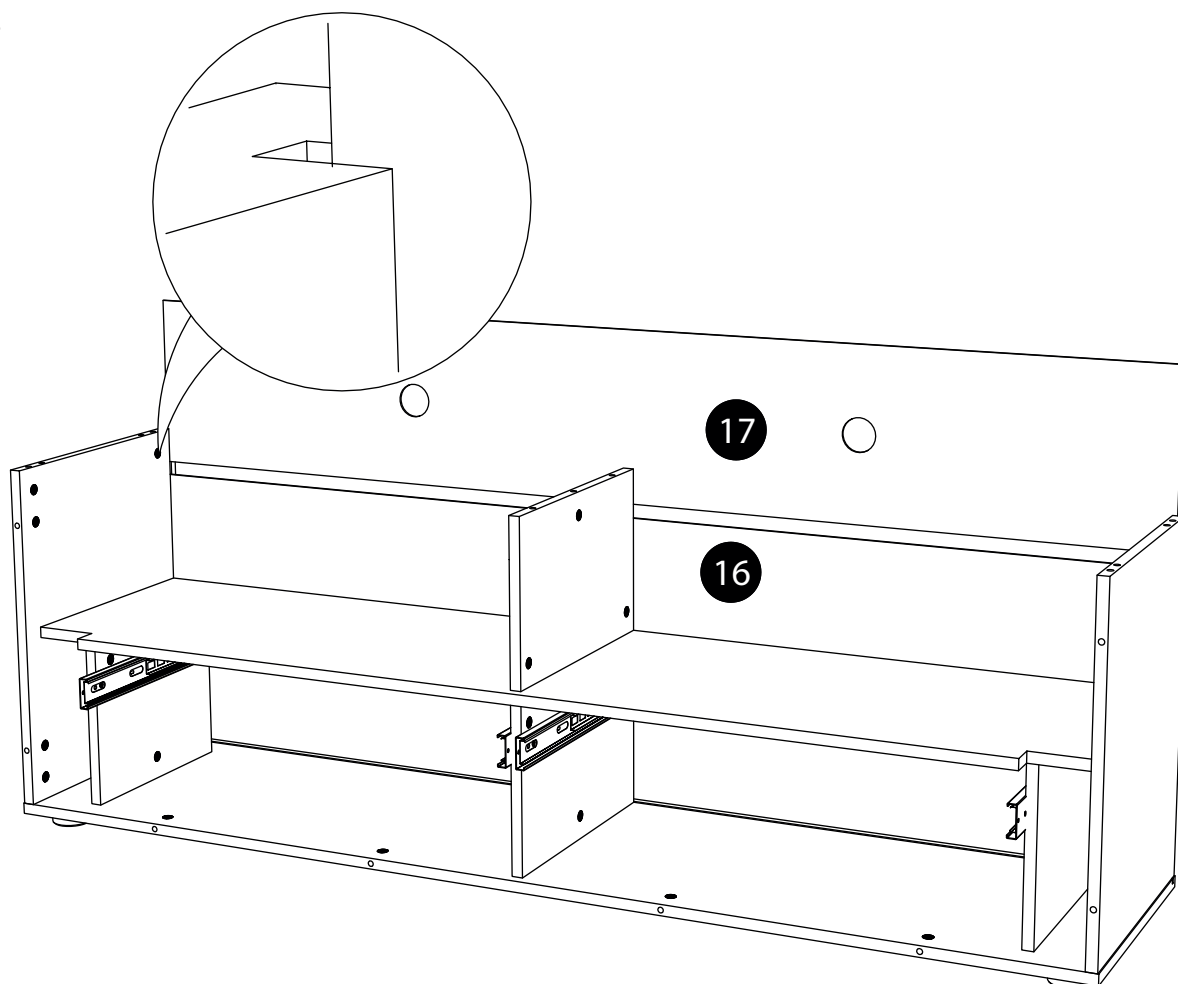

23.

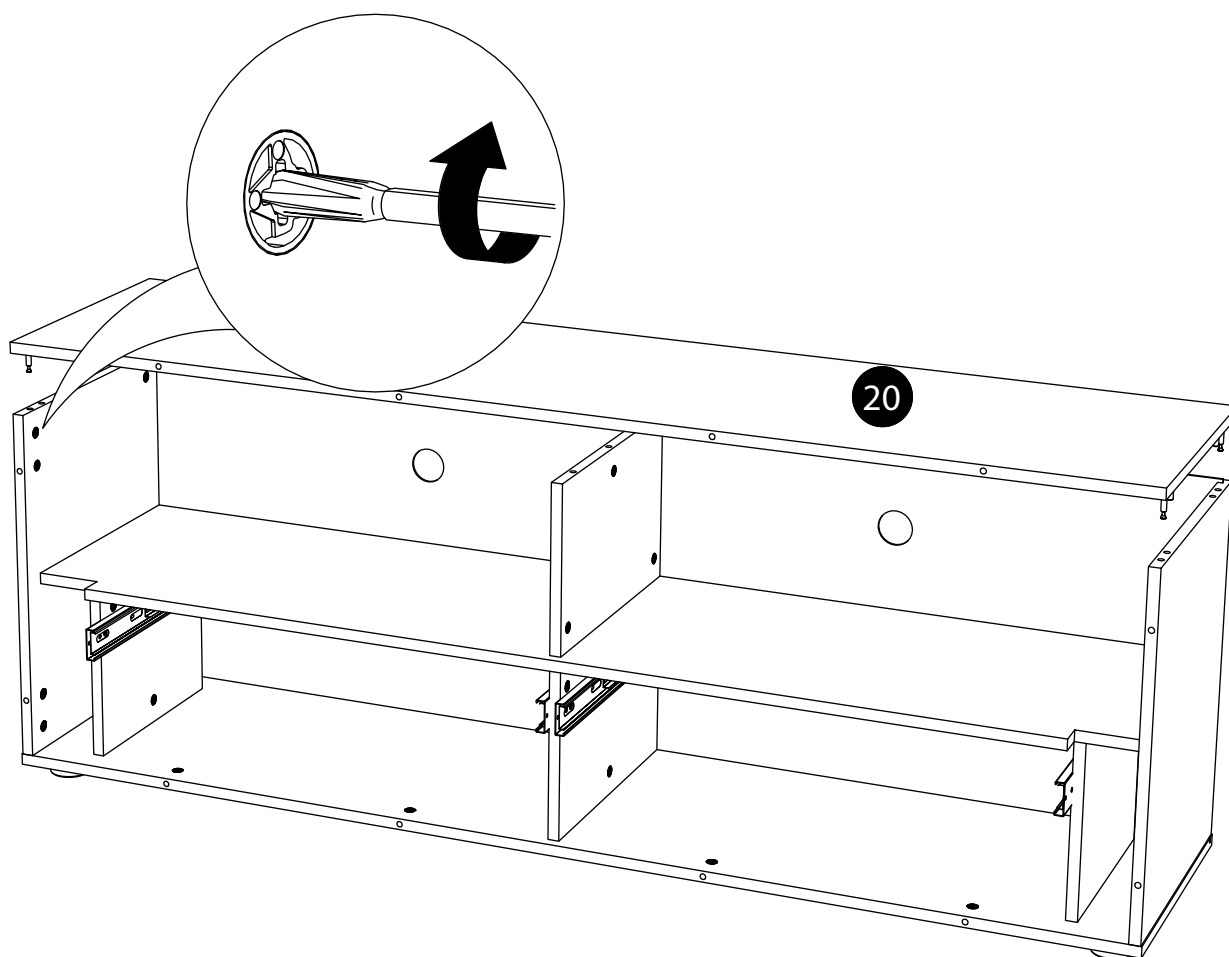

24.

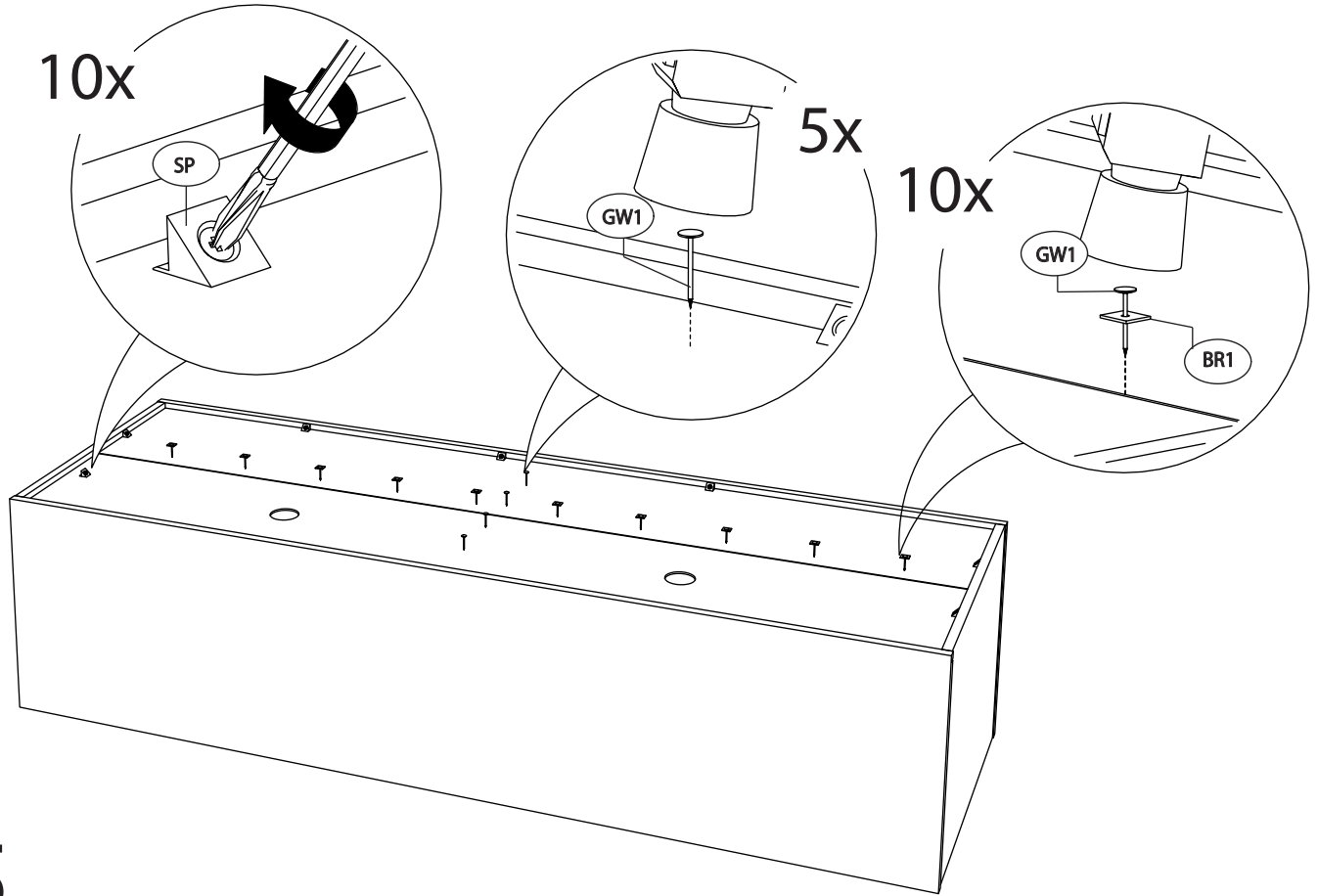
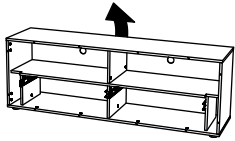

25.

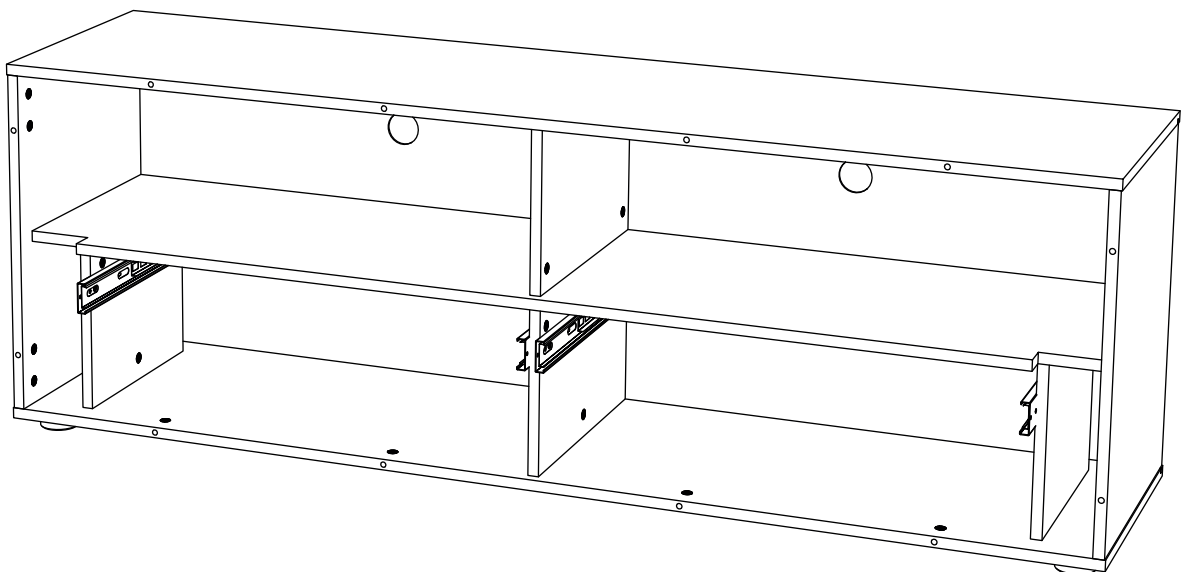
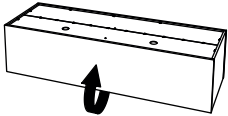

26.

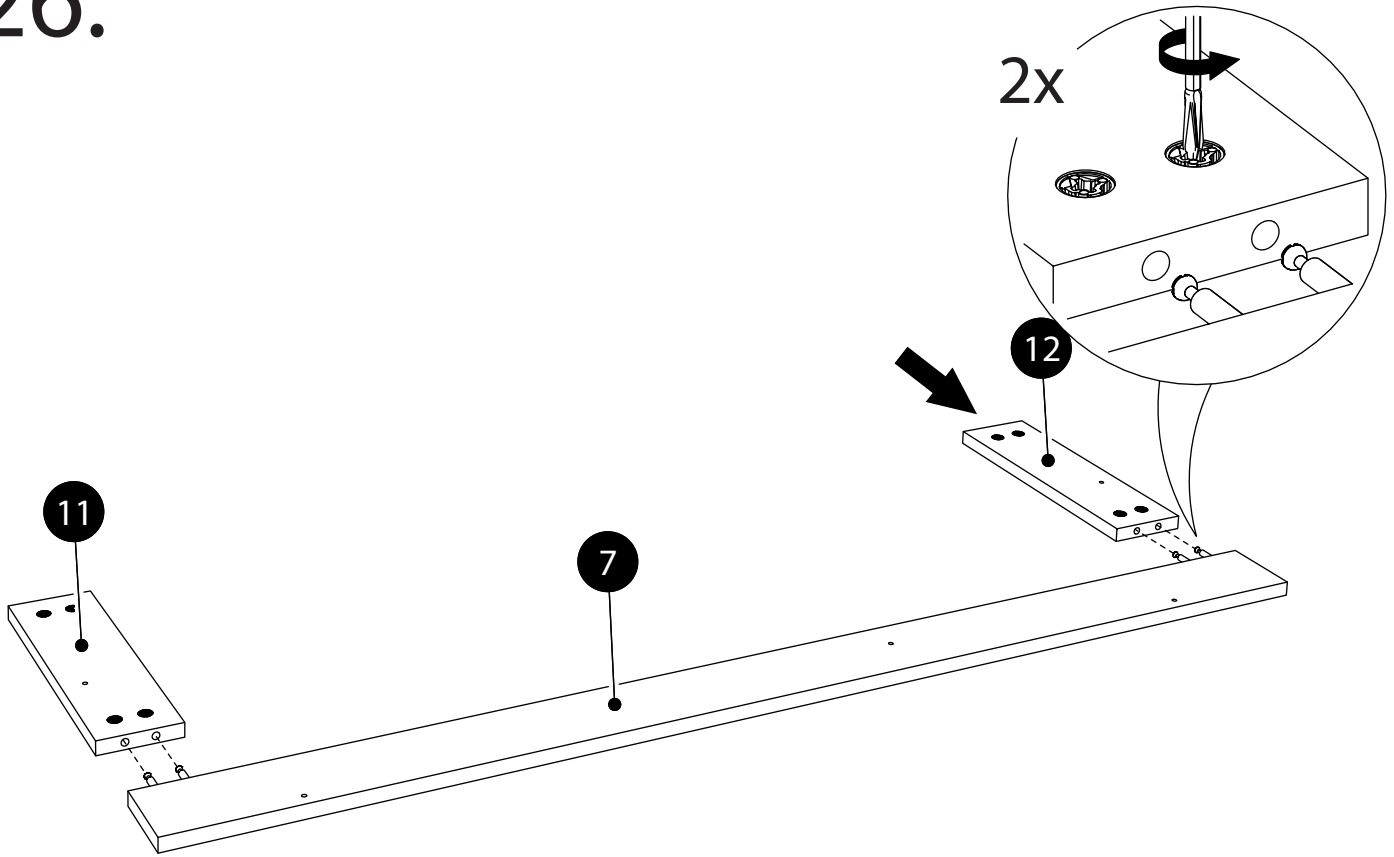

27.

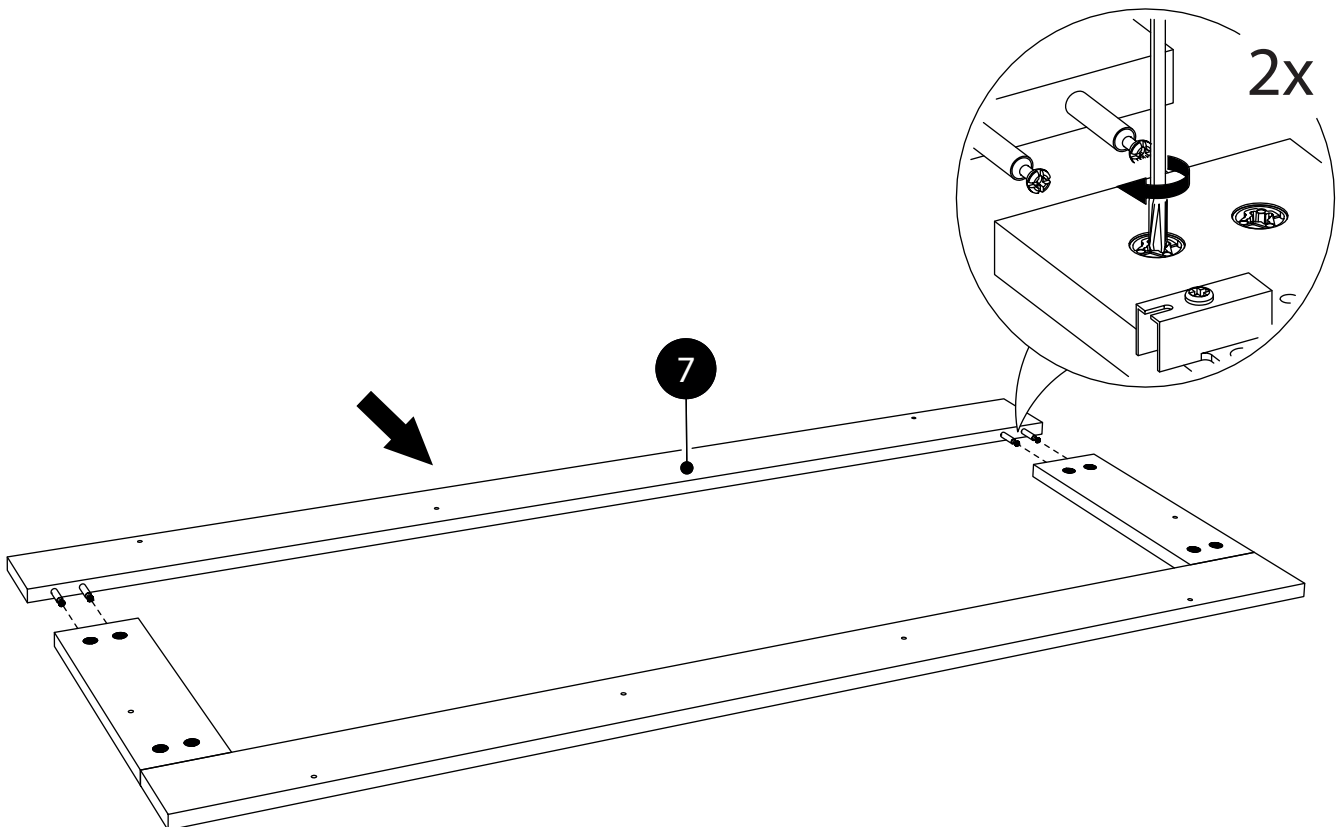

28.

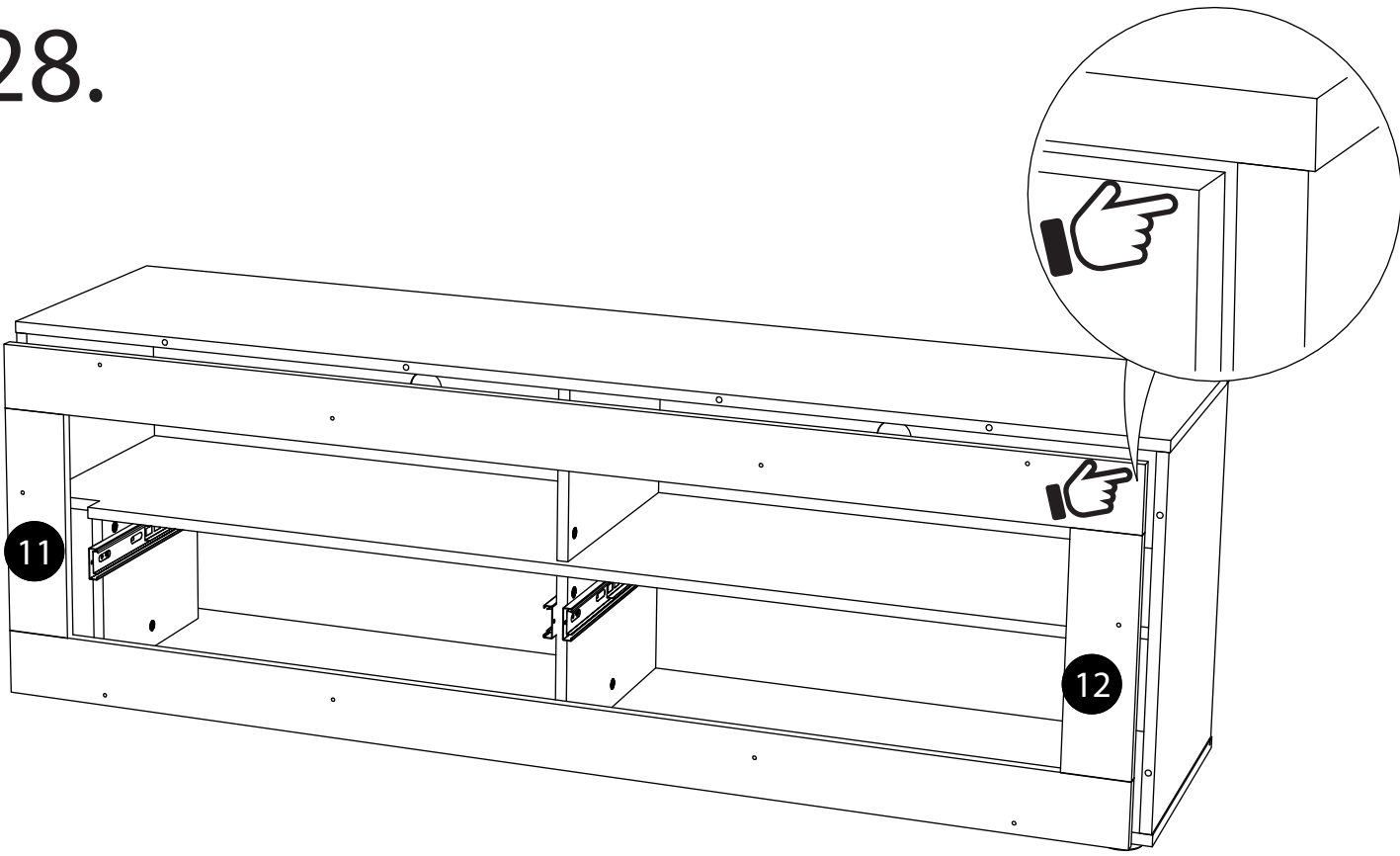

29.

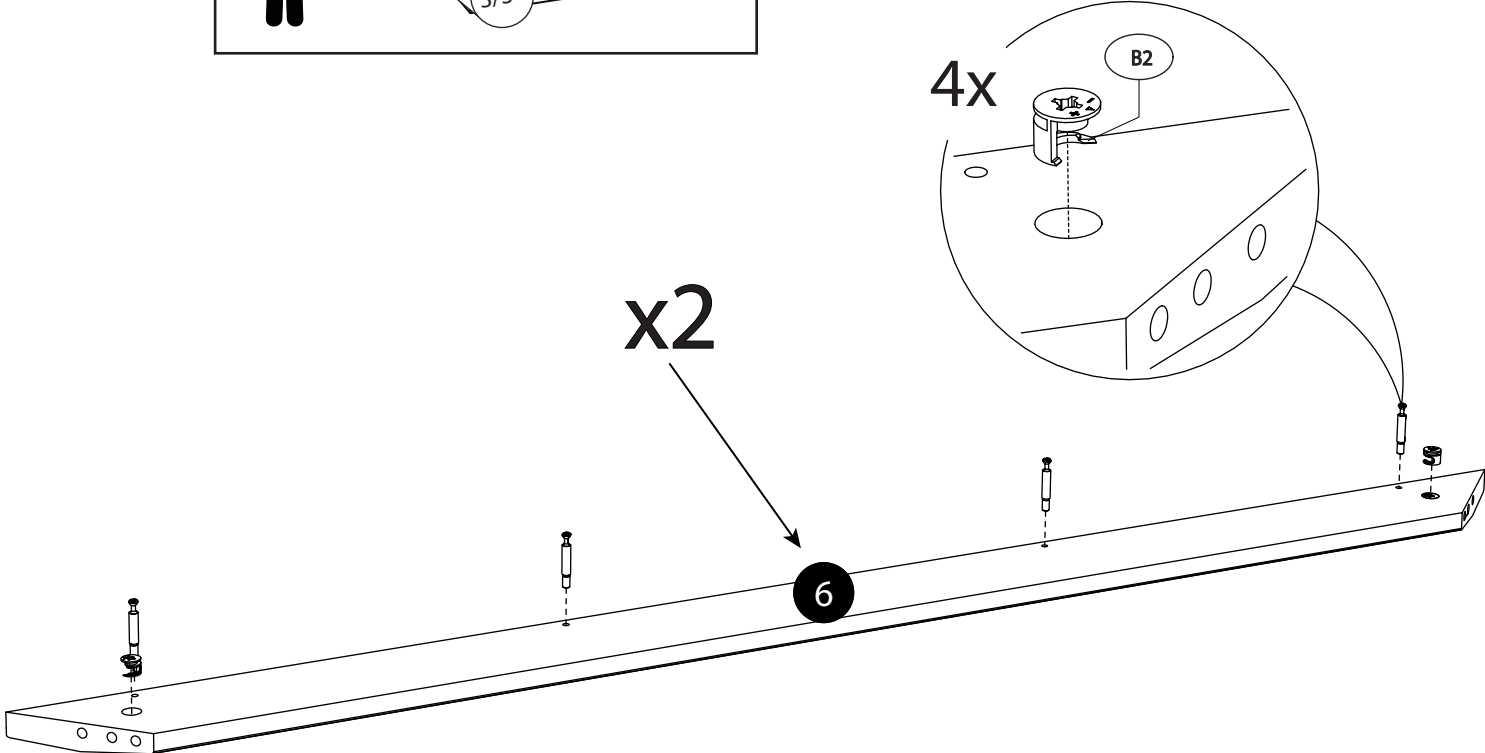
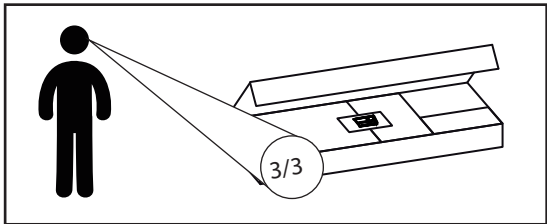

30.

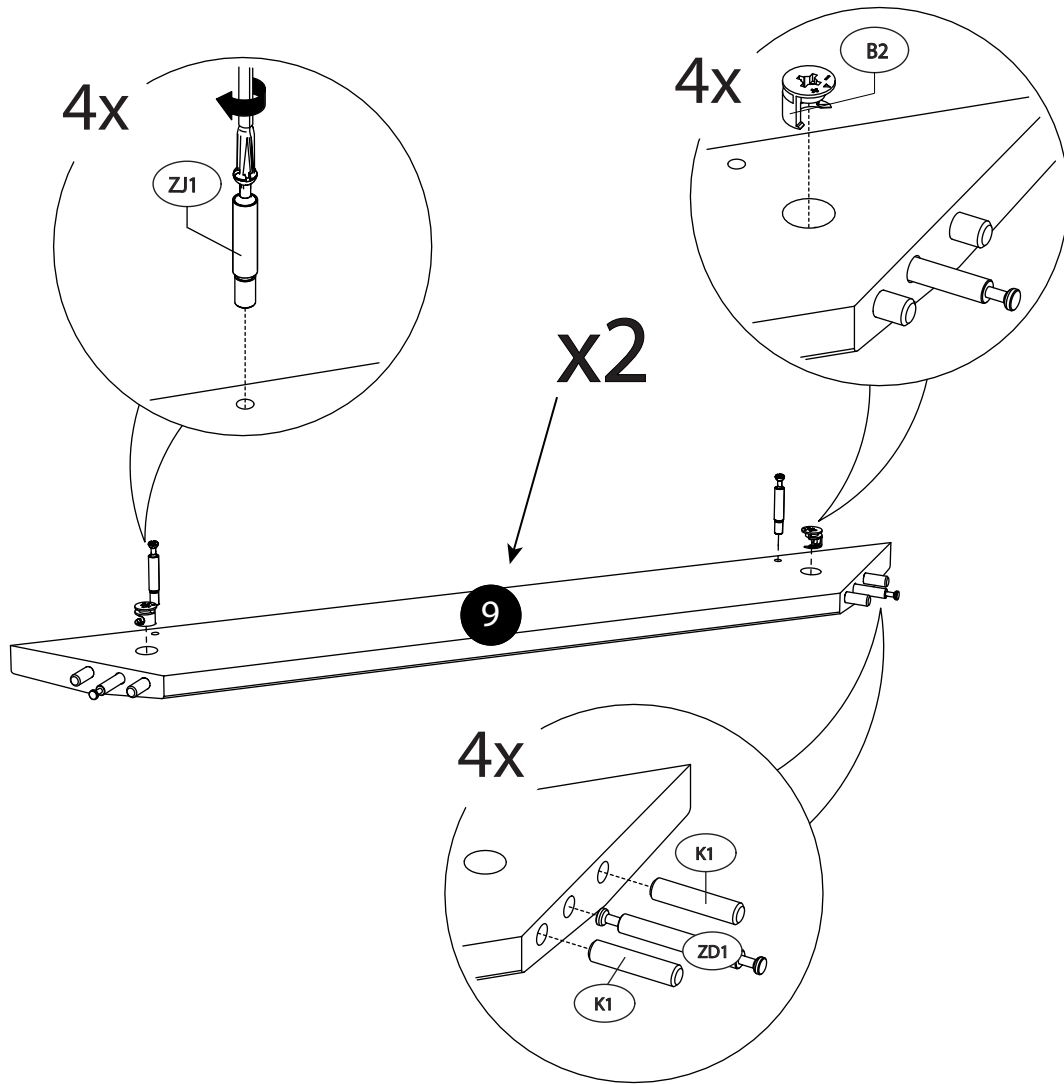

31.

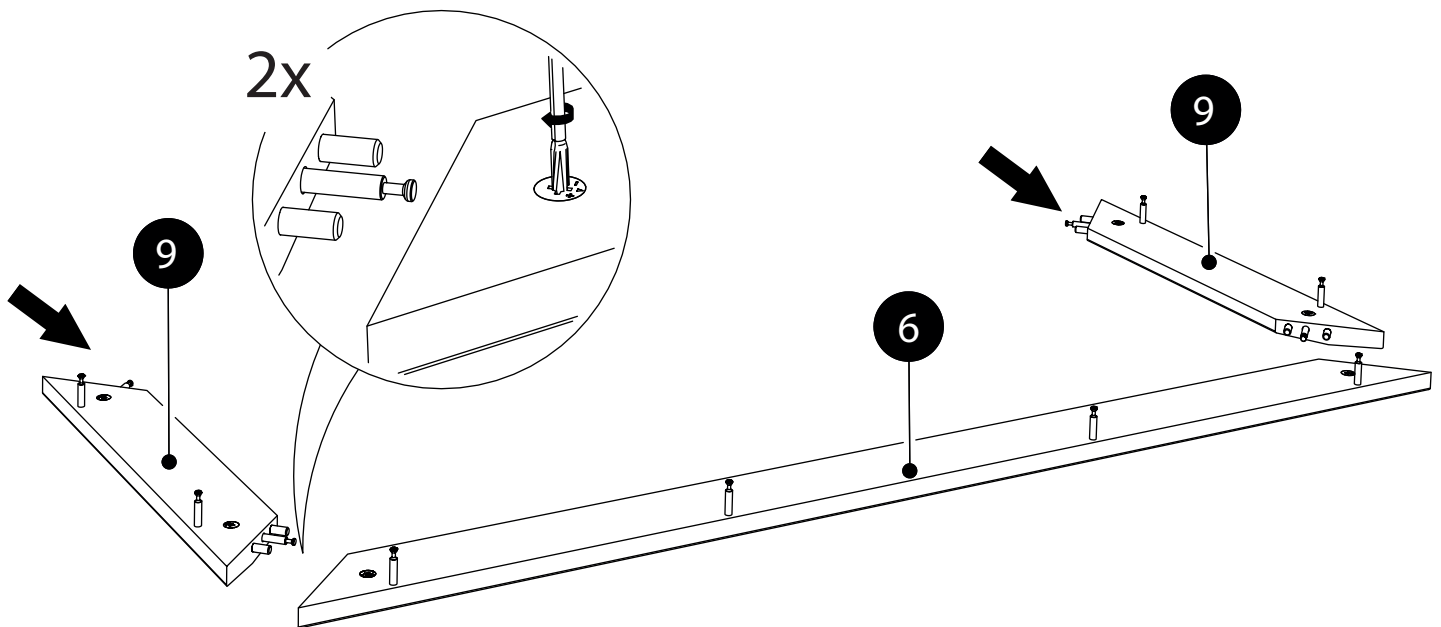

32.

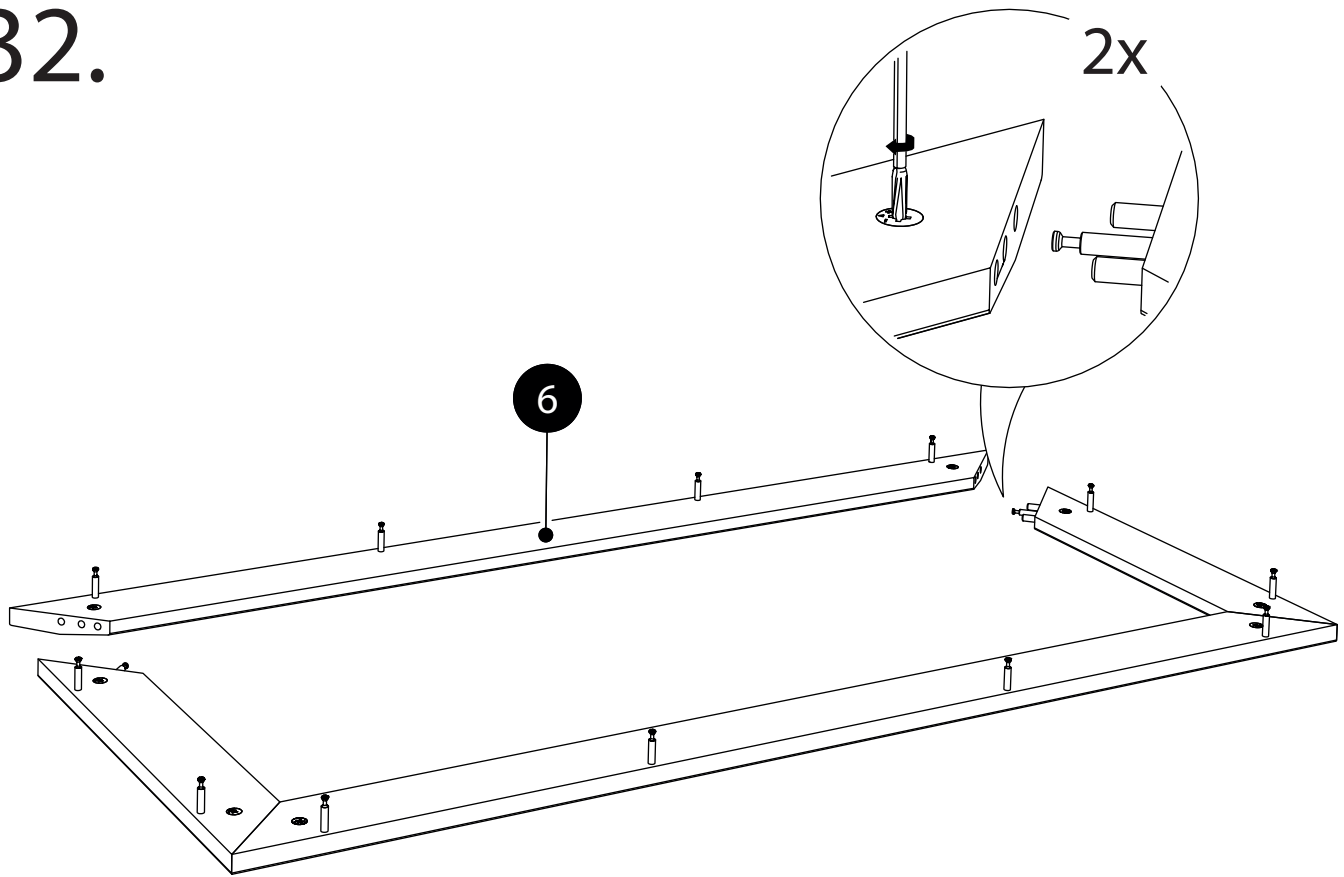

33.

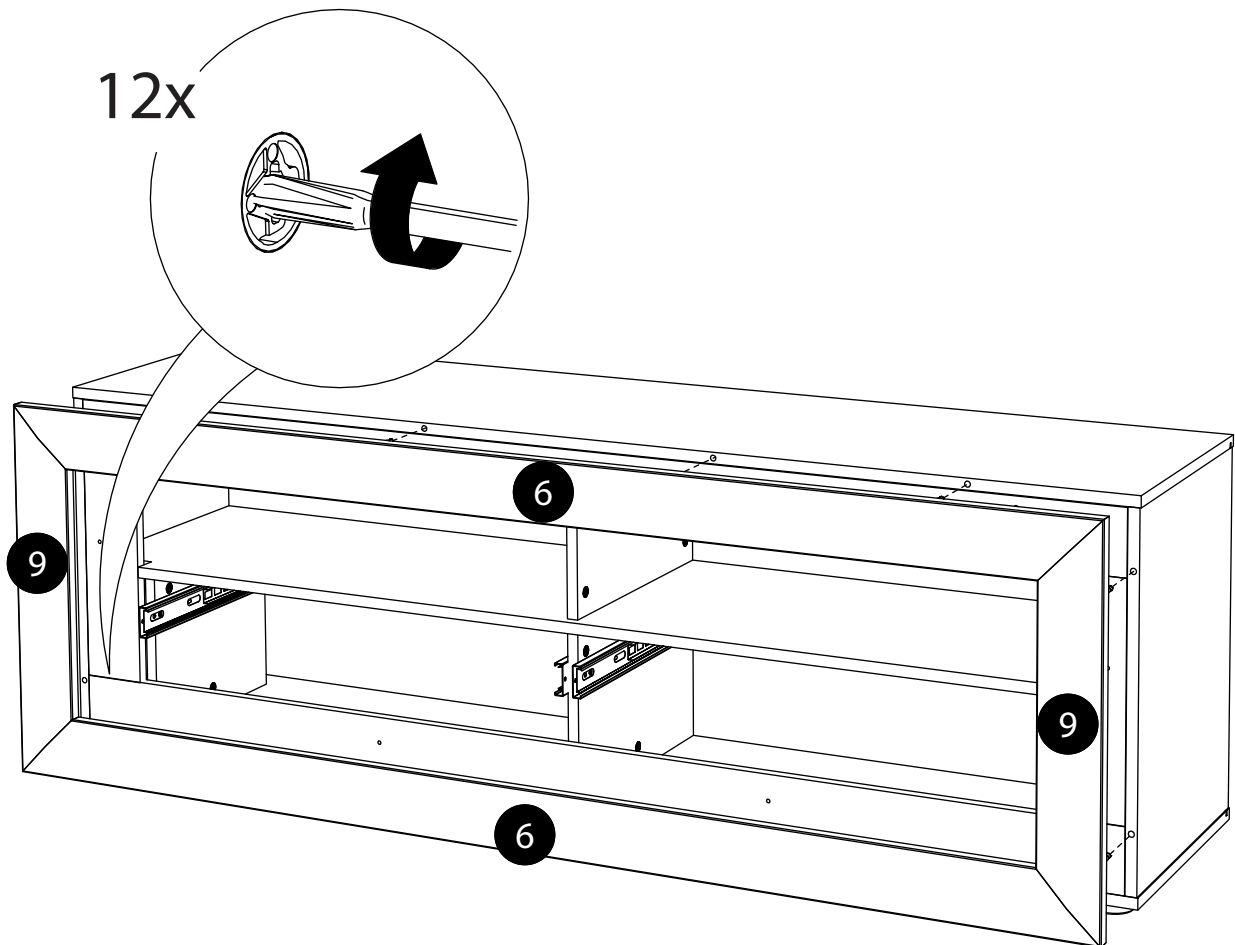

34.

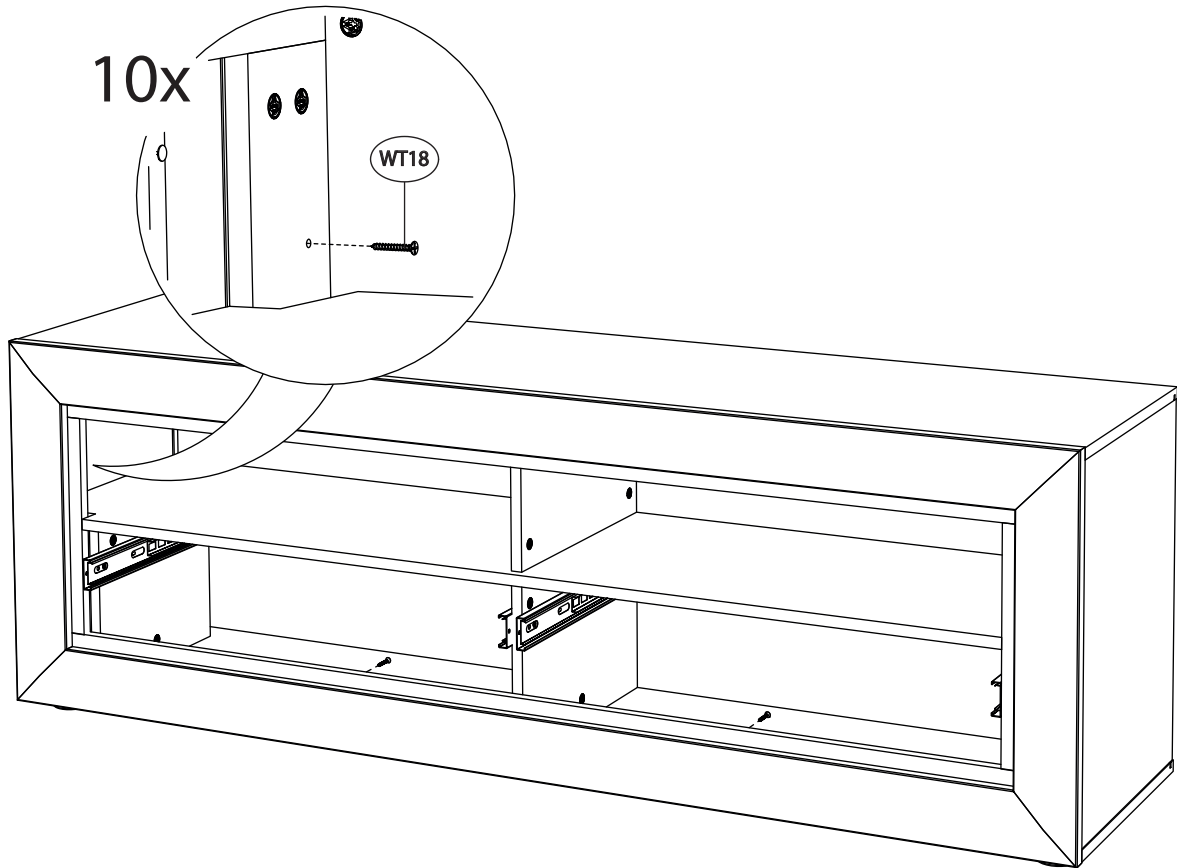

34.

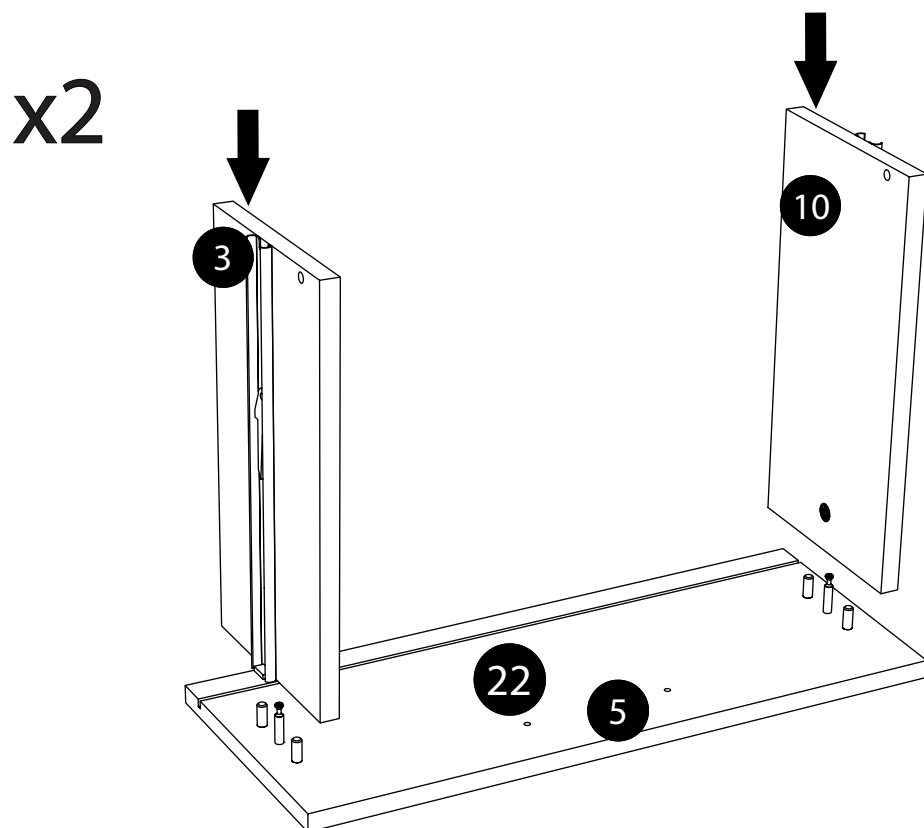

35.

x2

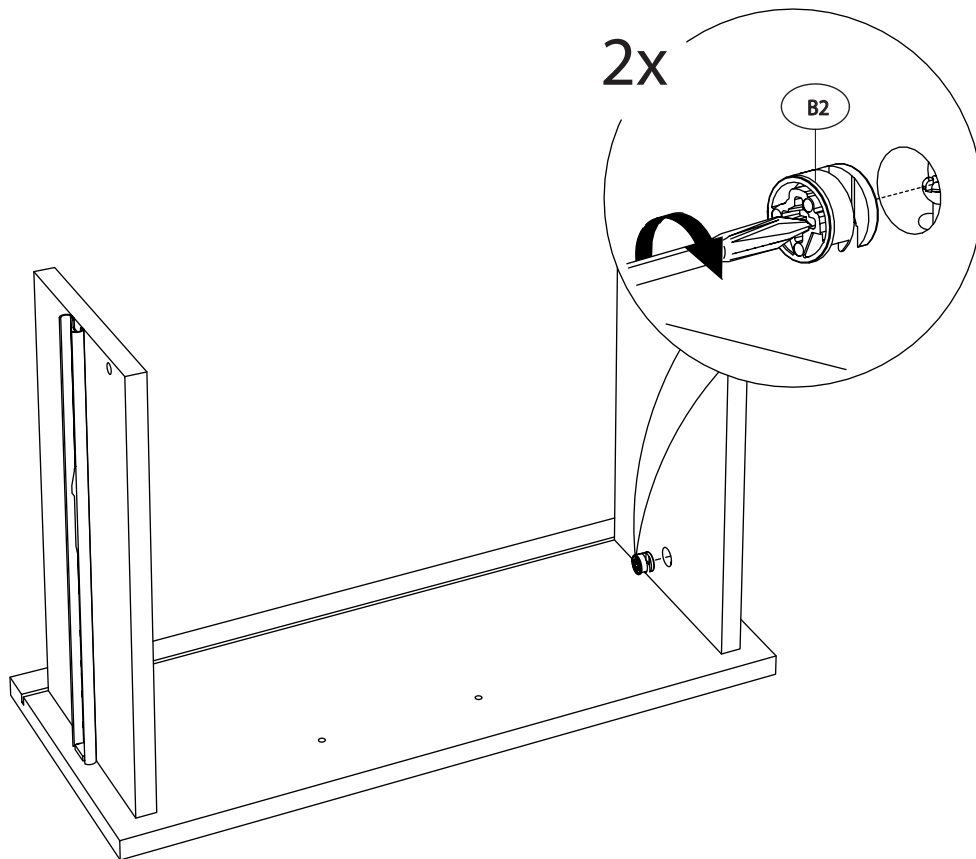

36.

x2

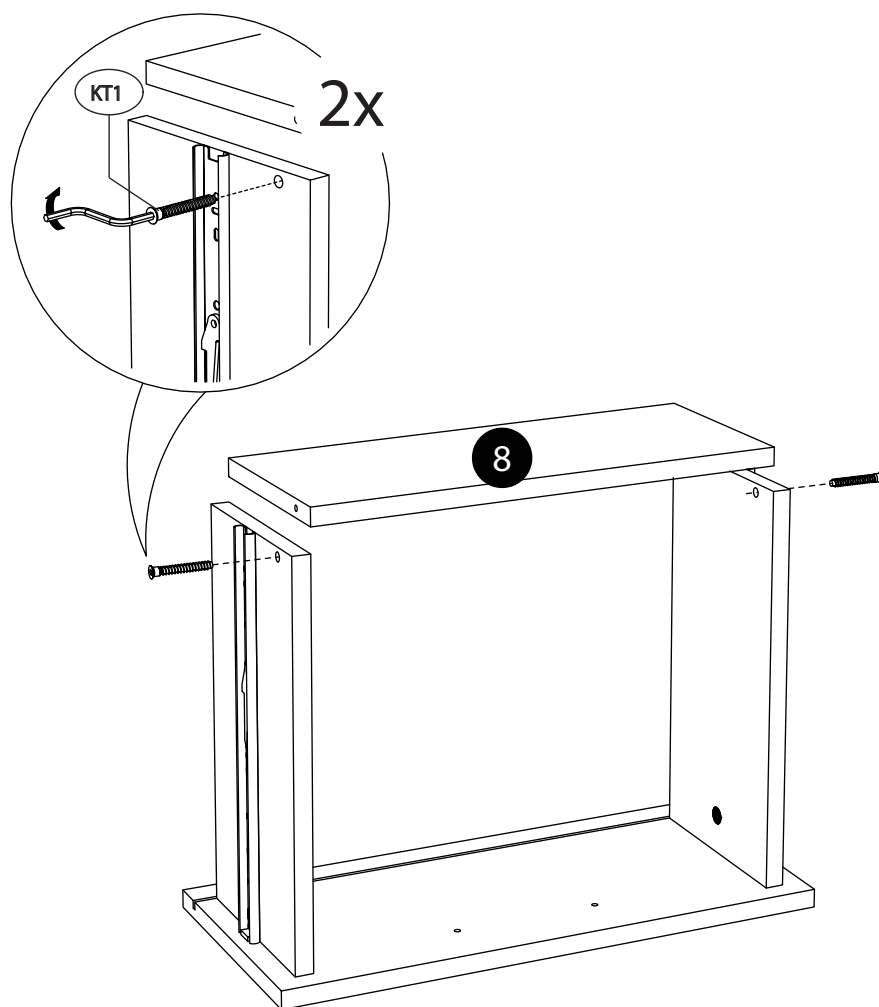

37.

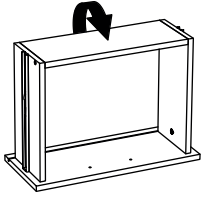

x2

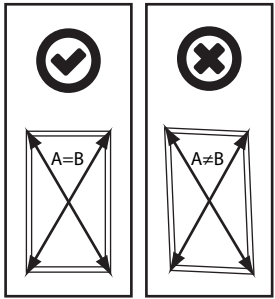
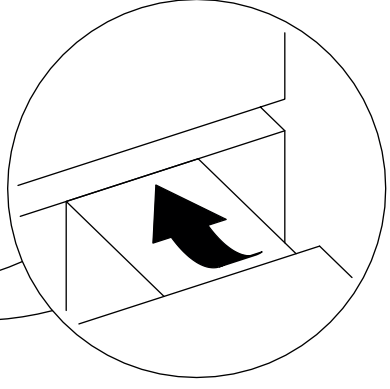
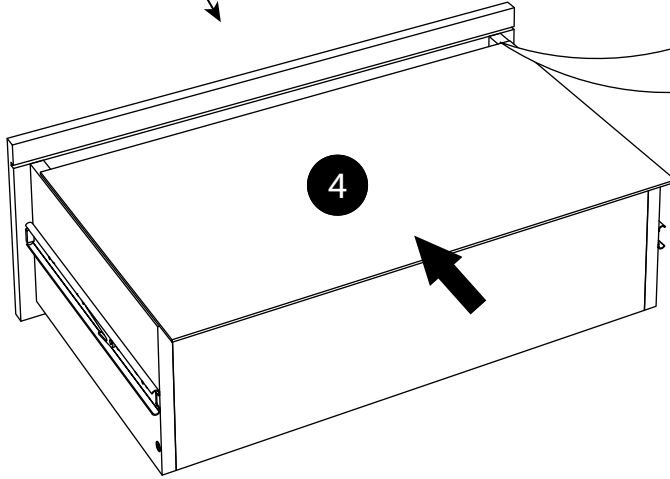

38.

x2

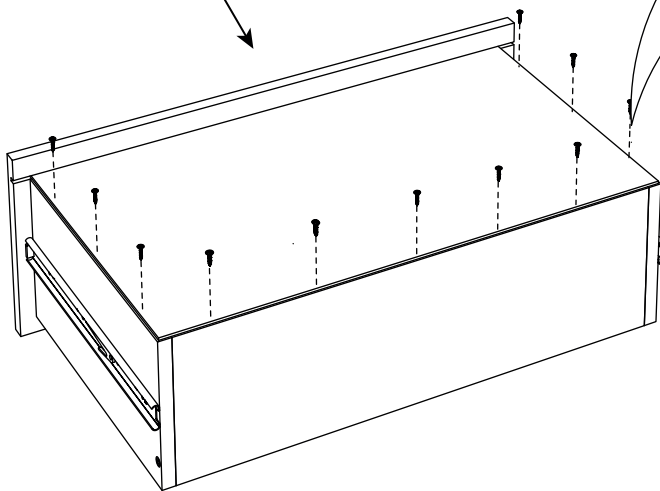

11x

WT9

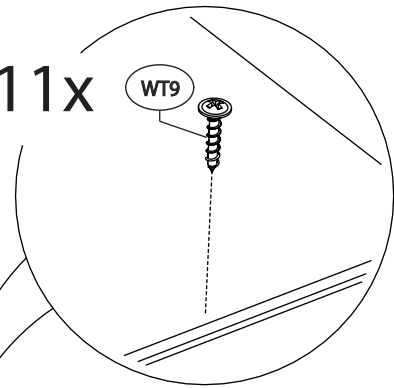

39.

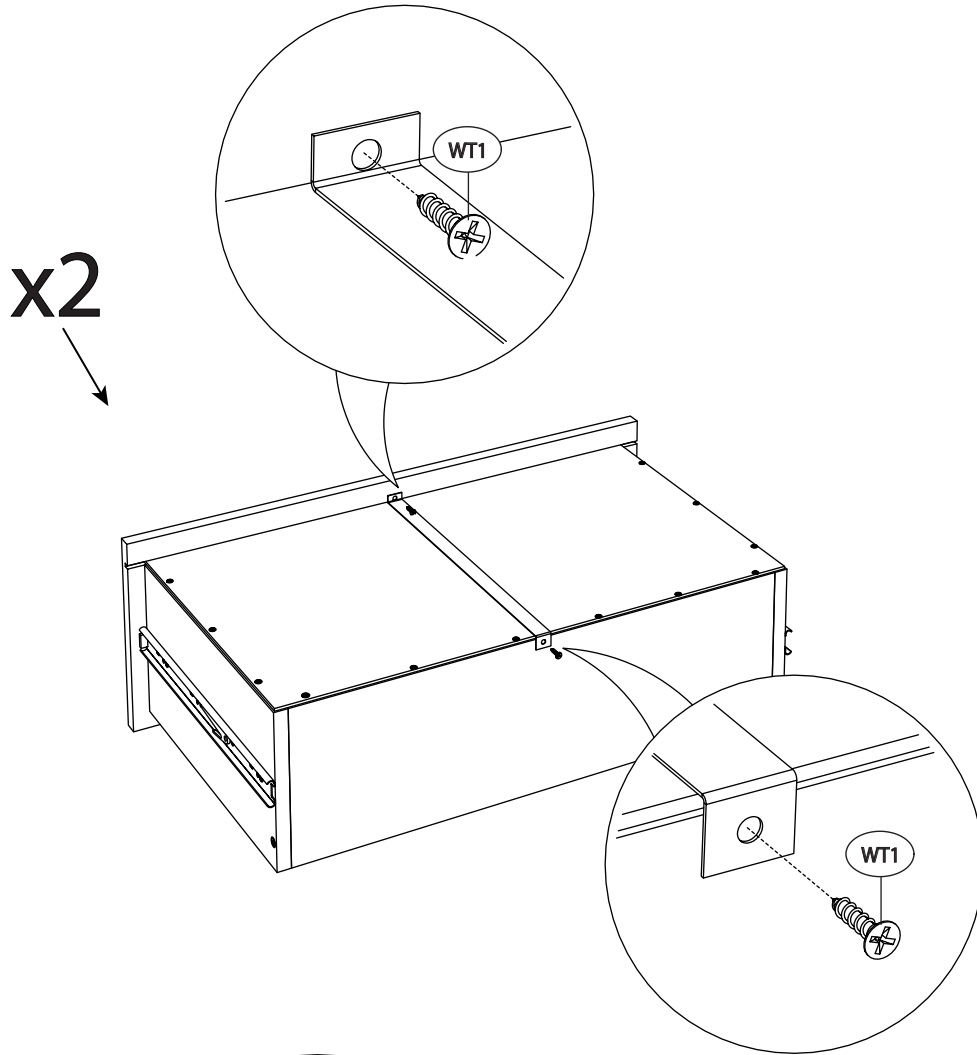

40.

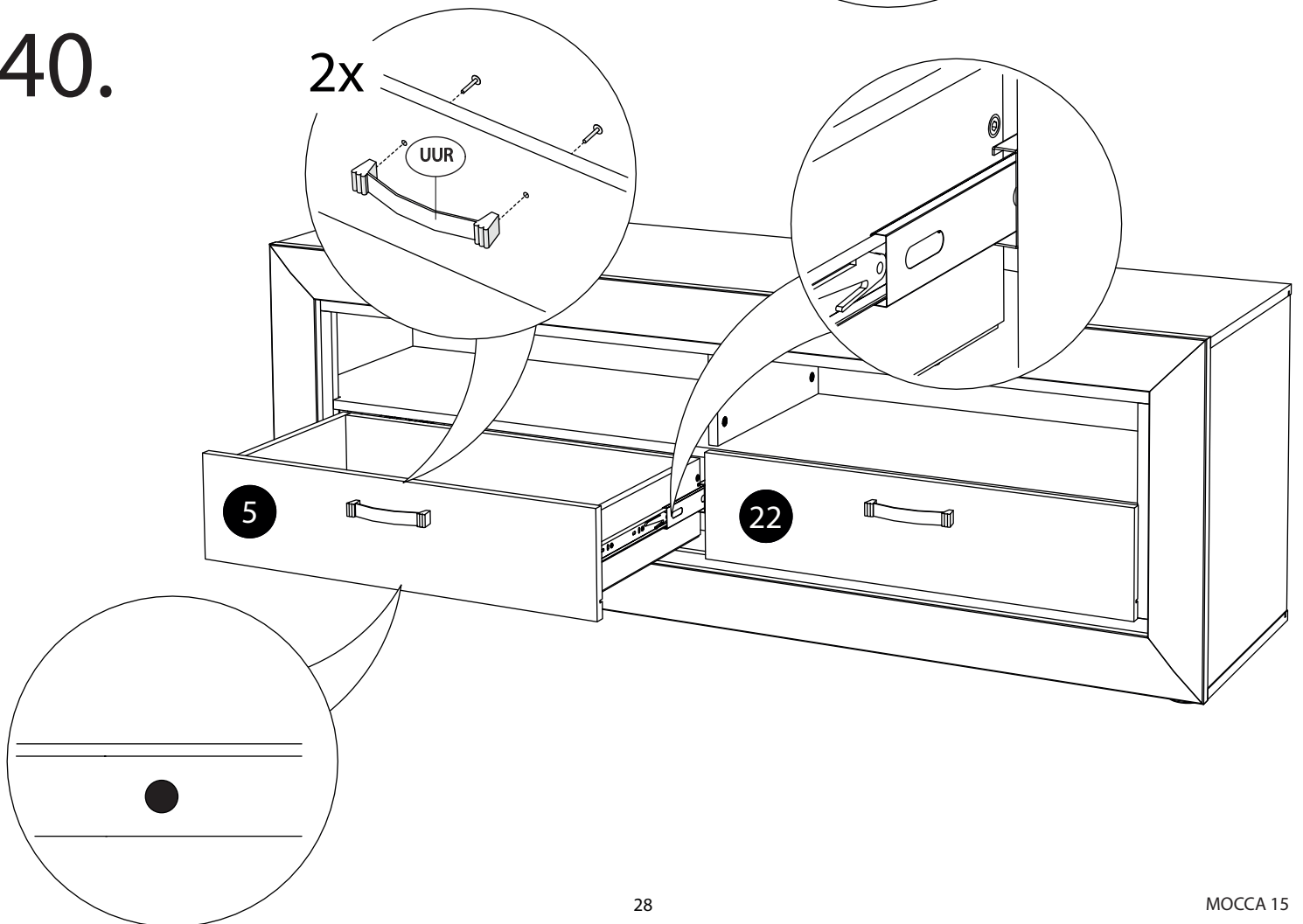

41.

