



ERVI 02

PL - Instrukcja montażu / BG - Сглобяване инструкция / CZ - Montáž instrukce / DE - Montageanleitung / EN - Assembling instruction / ES - Montaje de instrucción / EST - Paigaldusjuhend / FR - Notice de montage / HR - Sastavljanje upute / HU - Szerelési utasítás / I - Istruzioni di montaggio / LT - Montavimo instrukcija / LV - Montāžas instrukcija / NL - Montage instructie / P - Montagem de instrução / RO - Asamblarea de instrucțiuni / RU - Инструкция сборки / S - Monteringsinstruktion / SK - Montáž inštrukcie / SLO - Sestavljanje navodila / SRB - Skлапање инструкции / TR - Kurulum Talimatları / UKR - Збірка інструкція /

PL - Przed rozpoczęciem zapoznać się z instrukcją montażu / BG - Преди да започнете се отнасят към инструкциите за инсталиране / CZ - Před zahájením naleznete v montážním návodu / DE - Vor die montage, bitte beiliegende anweisungen folgen / EN - Before starting, refer to the assembling advice in annex / ES - Antes de començar referirse a las instrucciones de instalación / EST - Enne käivitamist vaadake paigaldusjuhiseid / FR - Avant de commencer, se reporter aux conseils de montage en annexe / HR - Prije početka pogledajte upute za instalaciju / HU - Megkezdése előtt olvassa el a telepítési utasításokat / I - Avanti di cominciare, riportate agli consigli di montaggio / LT - Prieš pradendant kreiptis į montavimo instrukcija / LV - Pirms sākt montāžu, iepazīties ar instrukciju / NL - Voordat u begint Zie de installatie-instructies / P - Antes de começar a consultar as instruções de instalação / RO - Înainte de a începe să consultați instrucțiunile de instalare / RU - Перед началом обратитесь к инструкции по установке / S - Innan du börjar se Installationsanvisningen / SK - Pred začatím nájdete v montážnom návode / SLO - Pred začetkom glejte navodila za nameštitev / SRB - Пре почетка погледајте упутства за инсталацију / TR - Kurulumla başl madan önce, montaj talimatnamesini sirasiyla takip edin. / UKR - Перед початком зверніться до інструкції з установки /



120 MIN

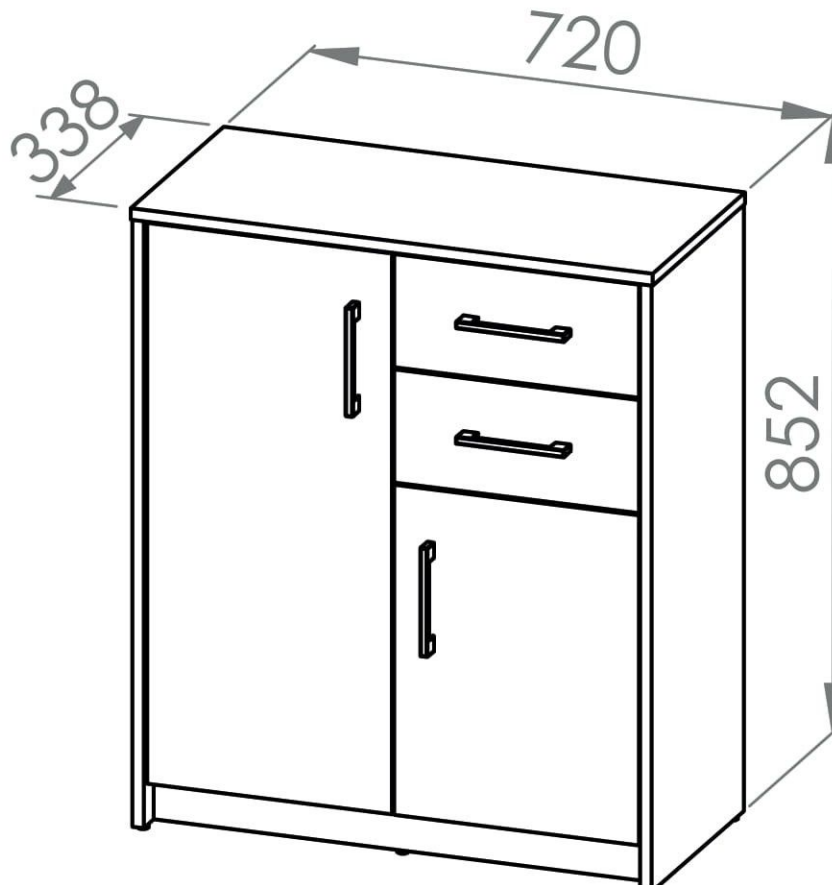
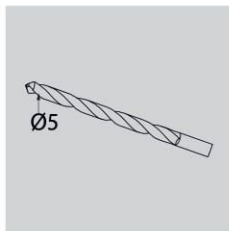
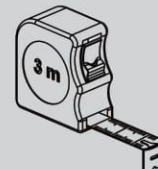
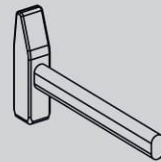
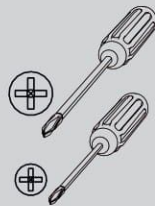

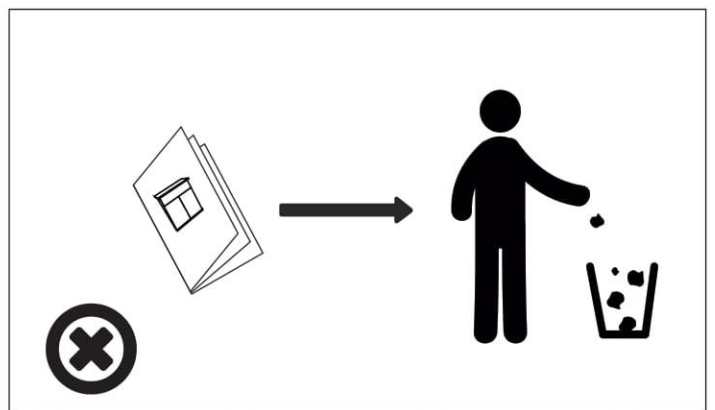
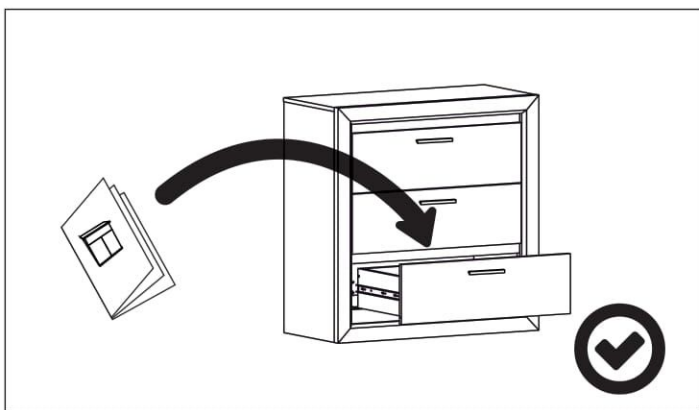
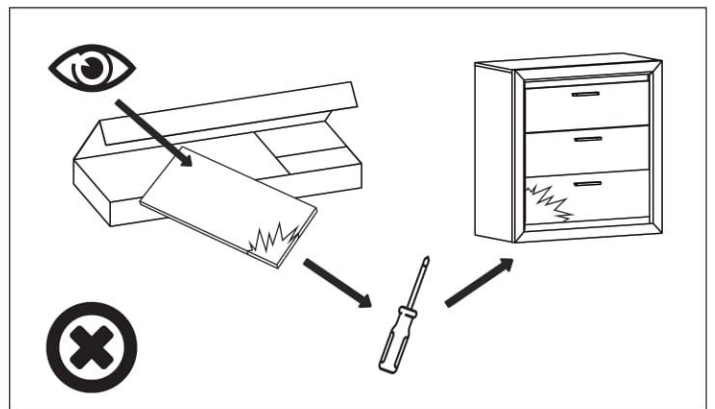
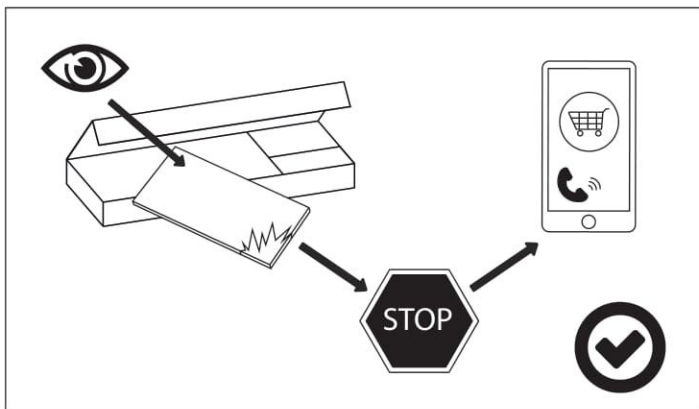
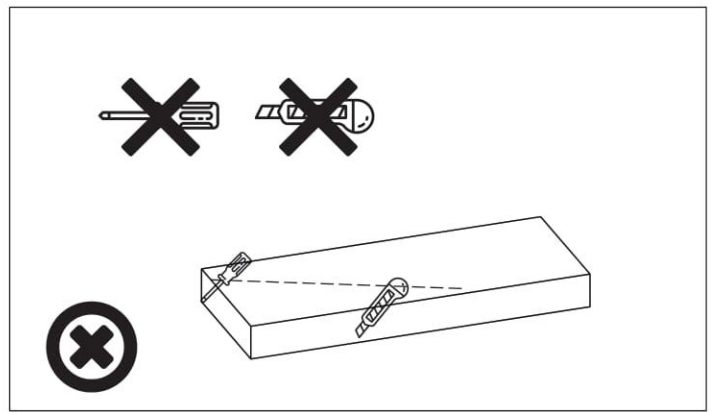
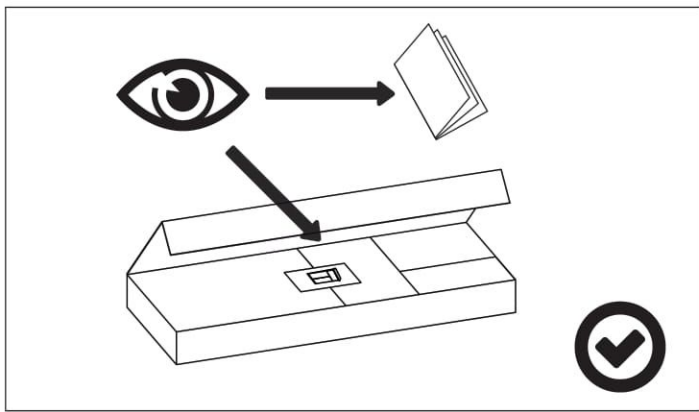





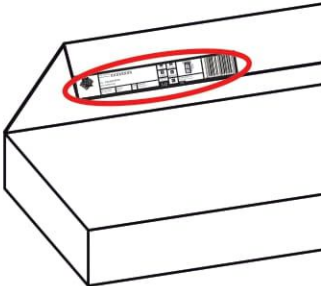

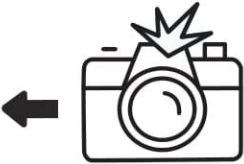



PL - Zachowaj w razie reklamacji !!! / BG - Пазете в случай на рекламация !!! / CZ - Uchovávejte pro případ stížnosti !!! / DE - Bewahren Sie das Etikett für Reklamationen !!! / ENG - Keep the label for complaints !!! / ES - Conservar en caso de reclamación !!! / EST - Kaebuse korral hoidke alles !!! / FR - Conserver en cas de réclamation !!! / HR - Zadržite u slučaju prigovora !!! / HU - Tartsa fenn panasz esetén !!! / IT - Conservare in caso di reclamo !!! / LT - Laikykite skundo atveju !!! / LV - Saglabājiet sūdzības gadījumā !!! / NL - Bewaren in geval van een klacht !!! / PO - Guarde em caso de reclamação !!! / RO - Păstrați în cazul unei reclamații !!! / RU - Сохранить в случае рекламации !!! / S - Förvara vid klagomål !!! / SK - Majte v prípade reklamácie !!! / SLO - Hranite v primeru pritožbe !!! / SRB - Zadržite u slučaju žalbe !!! / TR - Şikayet durumunda saklayın !!! / UKR - Зберігати у разі скарги !!!





Nazwa wyrobu: Product Name: XXXXXXXXXX			
Kolor: XXXXXXXXXX Color:XXXXXXXXXX			
Data produkcji: Production date: 0000-00-00	Pakujący: Packager: xx0/xx0	Szkló: Glass: 0	Kod paczki: Code packages: 0xxxxx00-000-0/0

	CODE				
1	1100201_09	300	92	4	1/1
2	1100201HDF_01	356	783	2	1/1
3	1100201_07	334	80	1	1/1
4	1100201_11	338	155	2	1/1
5	1100201_12	338	768	1	1/1
6	1100201_08	334	312	1	1/1
7	1100201_05	755	316	1	1/1
8	1100201_10	277	92	2	1/1
9	1100201_03	831	337	1	1/1
10	1100201_04	831	337	1	1/1
11	1100201_06	685	60	1	1/1
12	1100201HDF_02	307	307	2	1/1
13	1100201_02	685	317	1	1/1
14	1100201_01	720	338	1	1/1
15	1100201_13	338	452	1	1/1

	CODE				
16					
17					
18					
19					
20					
21					
22					
23					
24					
25					
26					
27					
28					
29					
30					

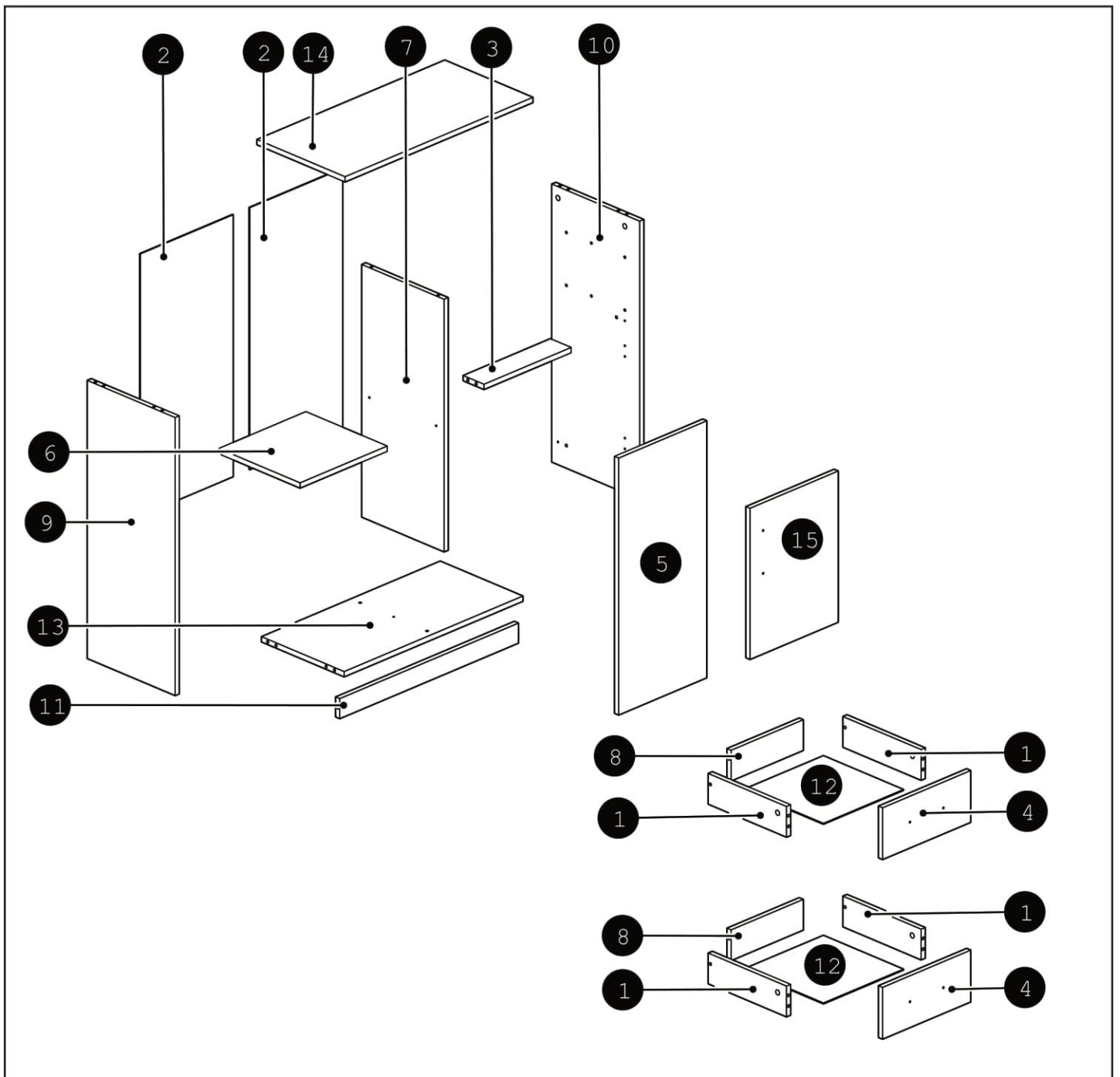

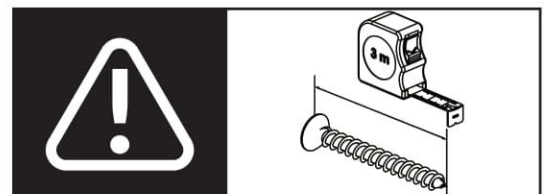
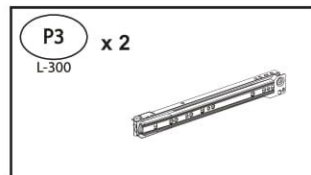
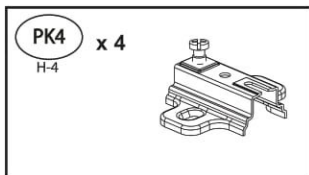
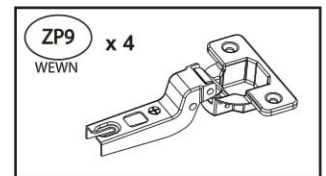
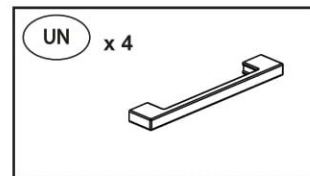
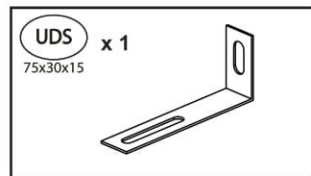
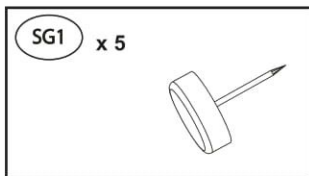
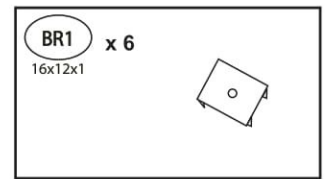
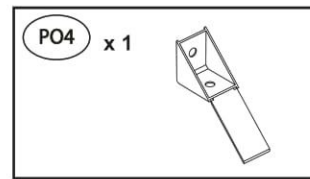
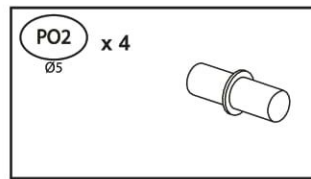
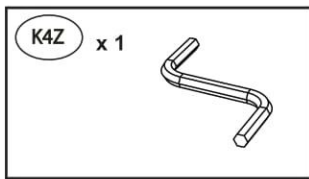
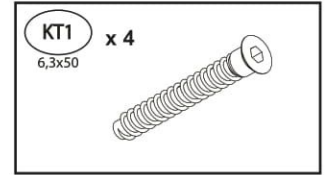
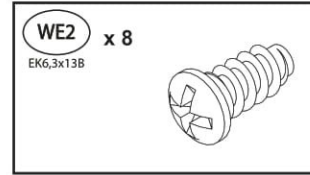
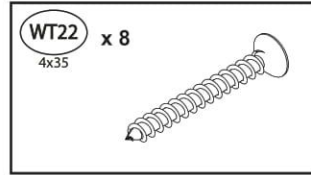
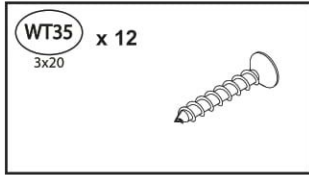
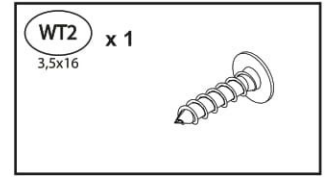
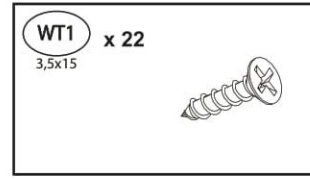
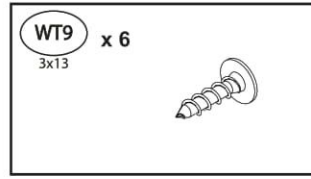
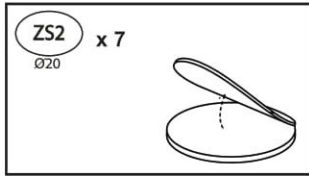
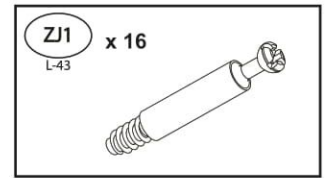
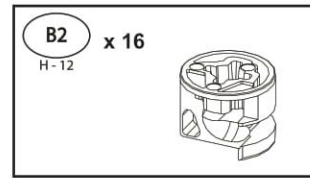
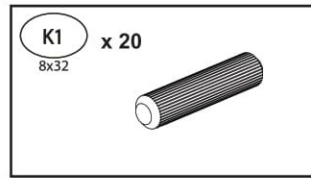
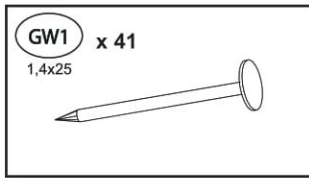

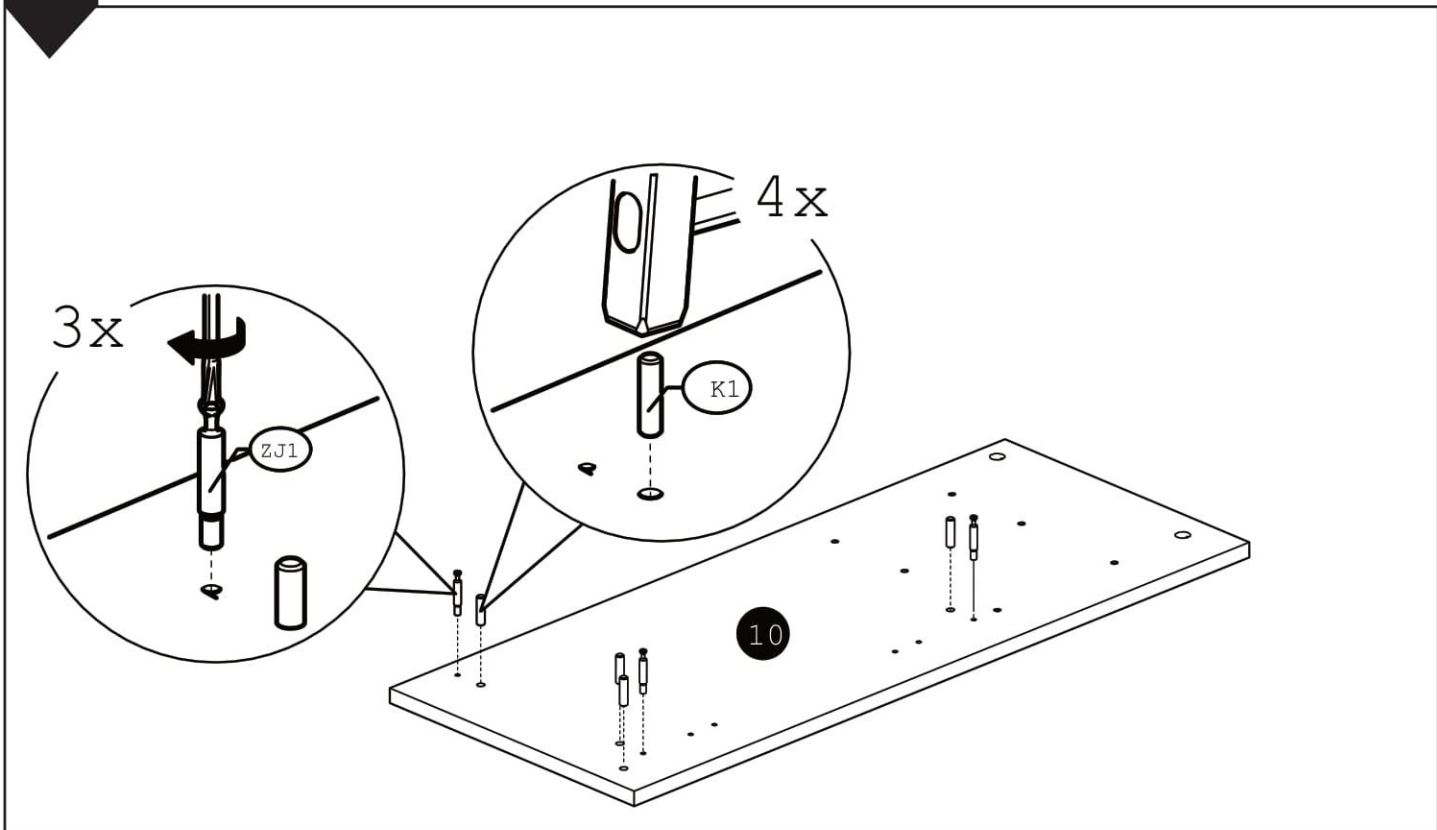
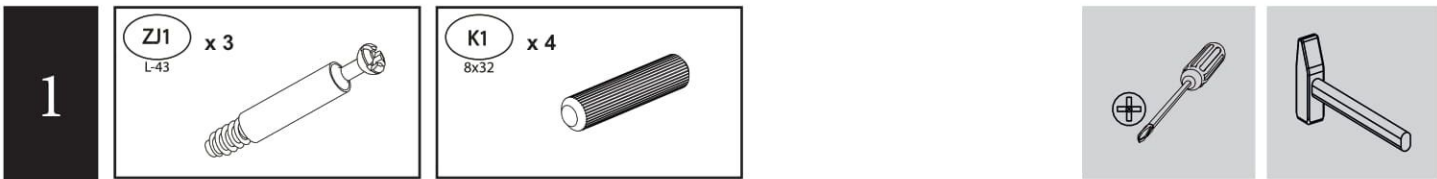
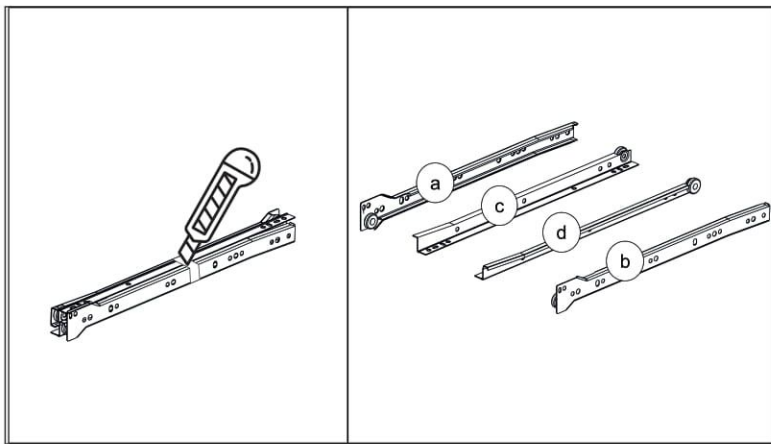
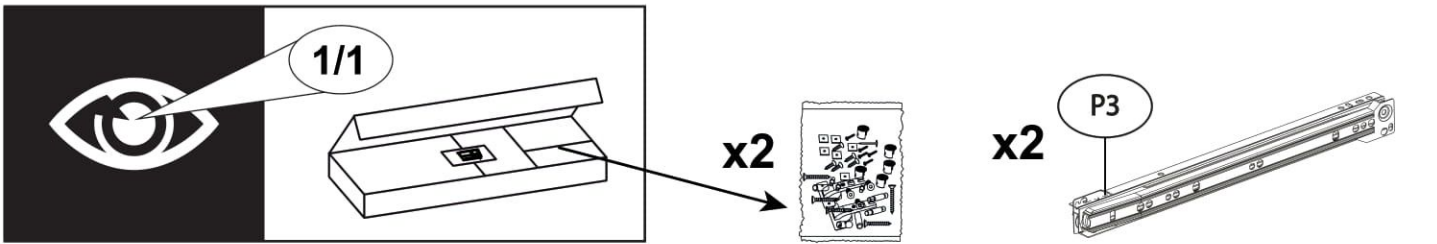
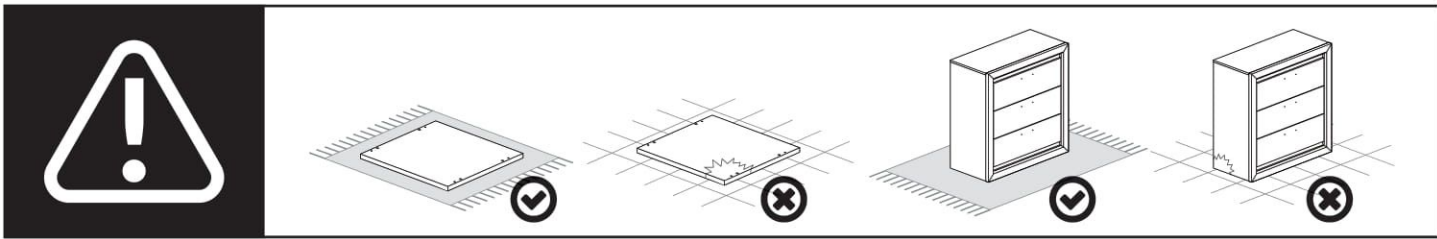

2

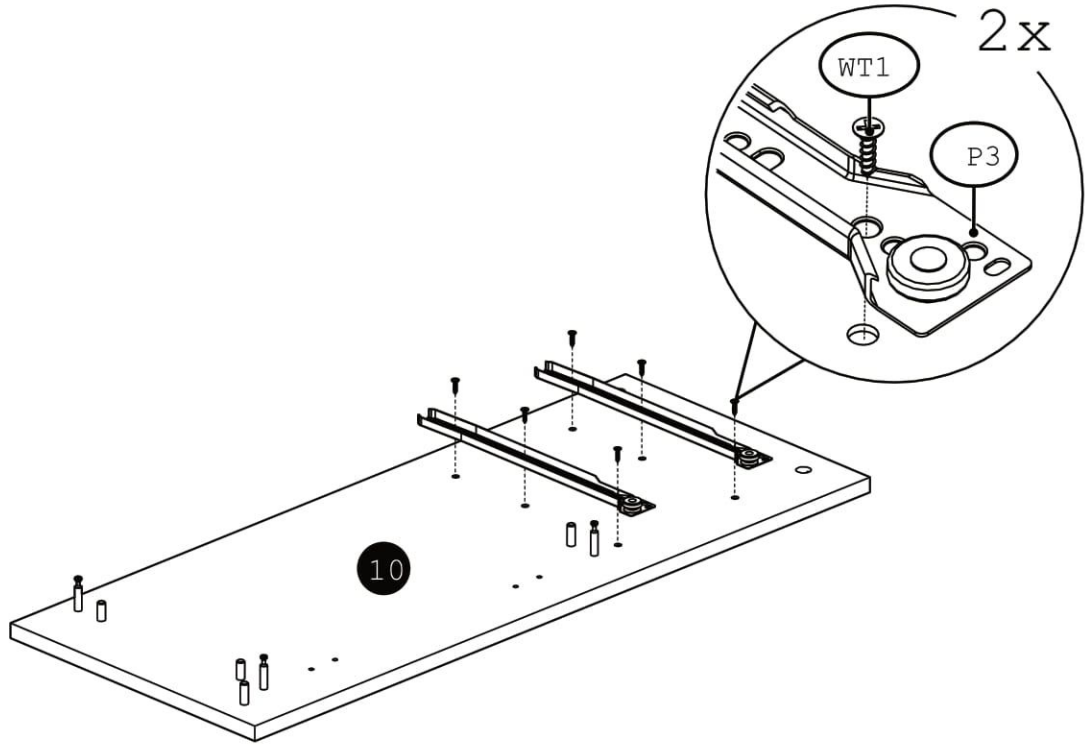
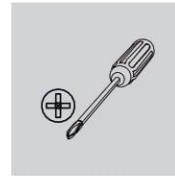
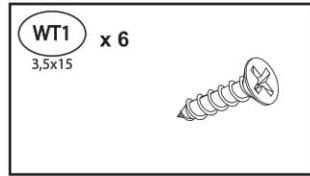
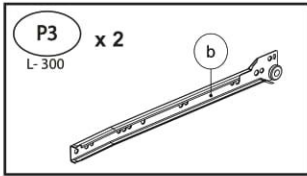

3

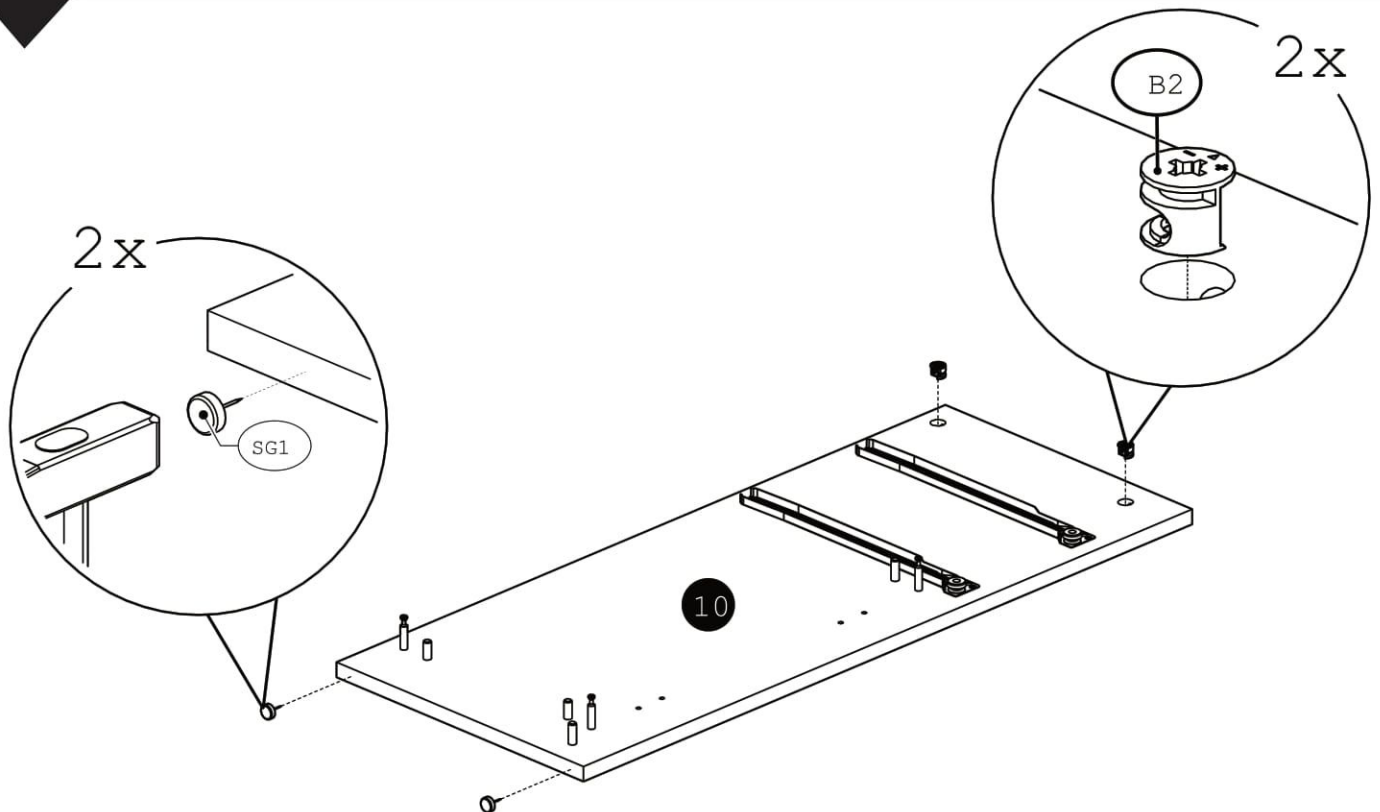
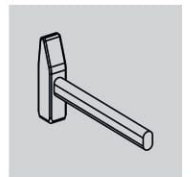
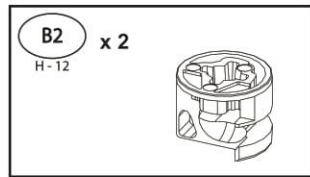
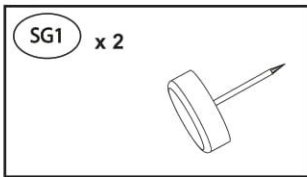

4

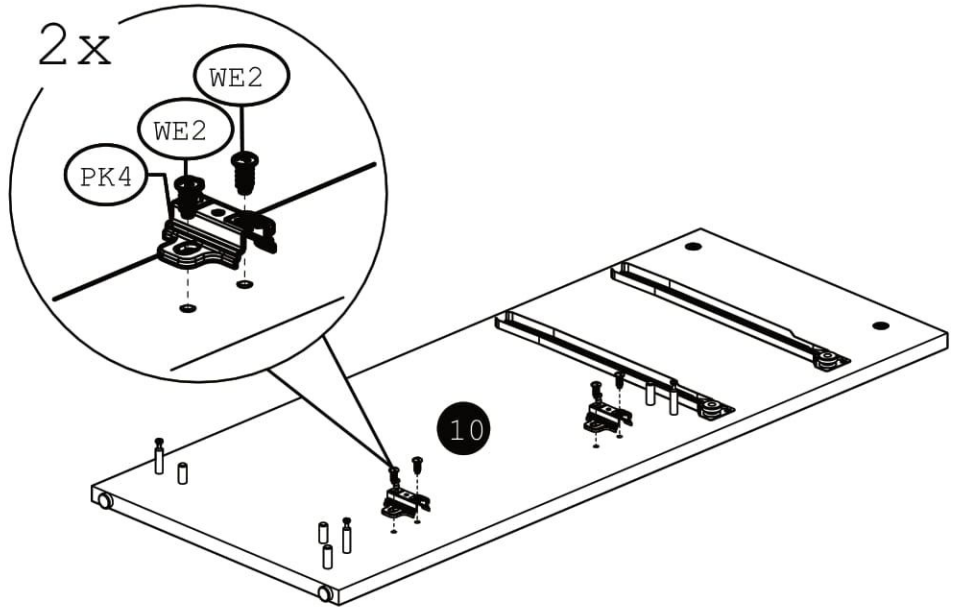
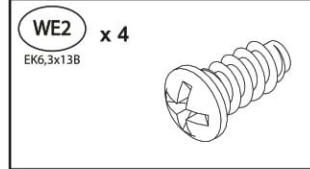
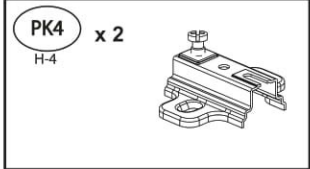

5

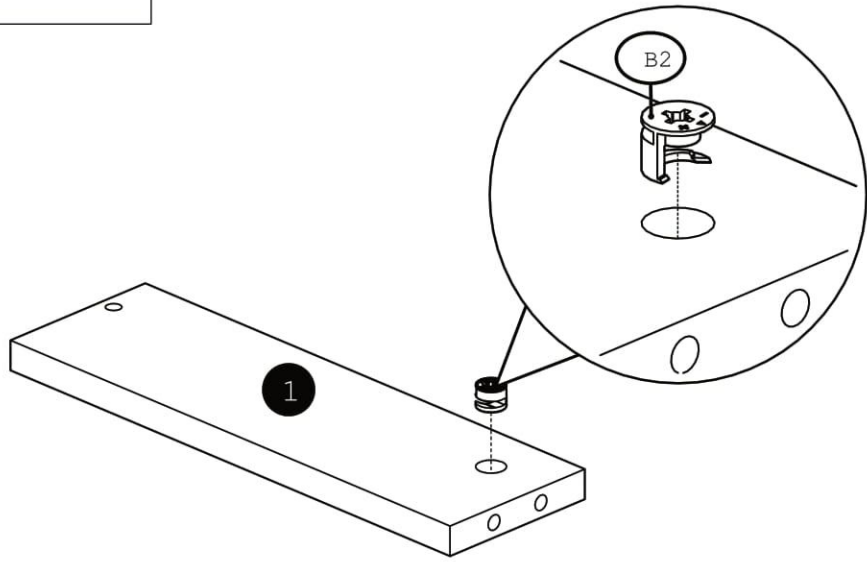
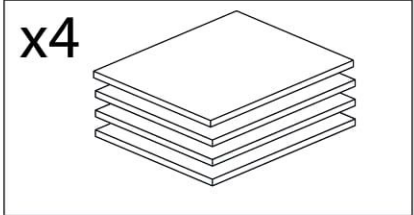
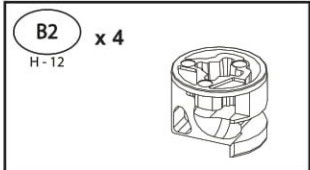

6

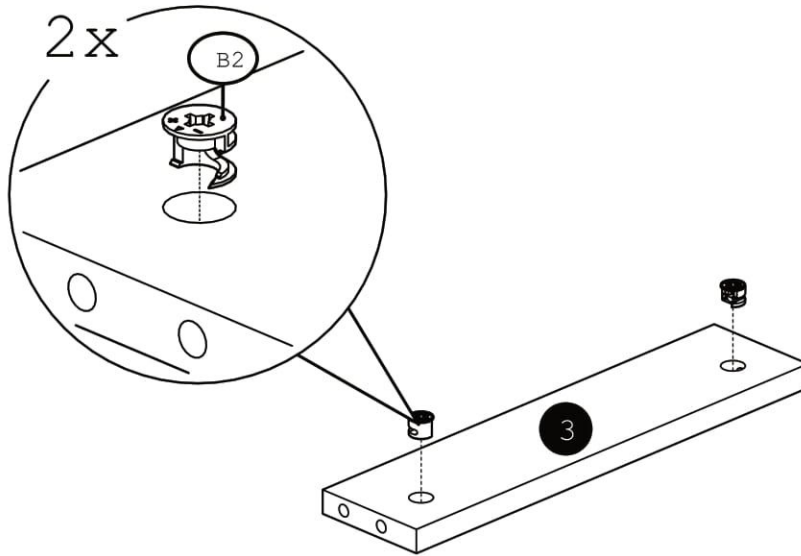
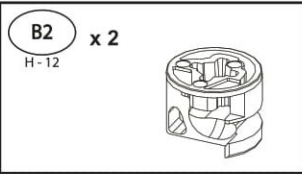

7

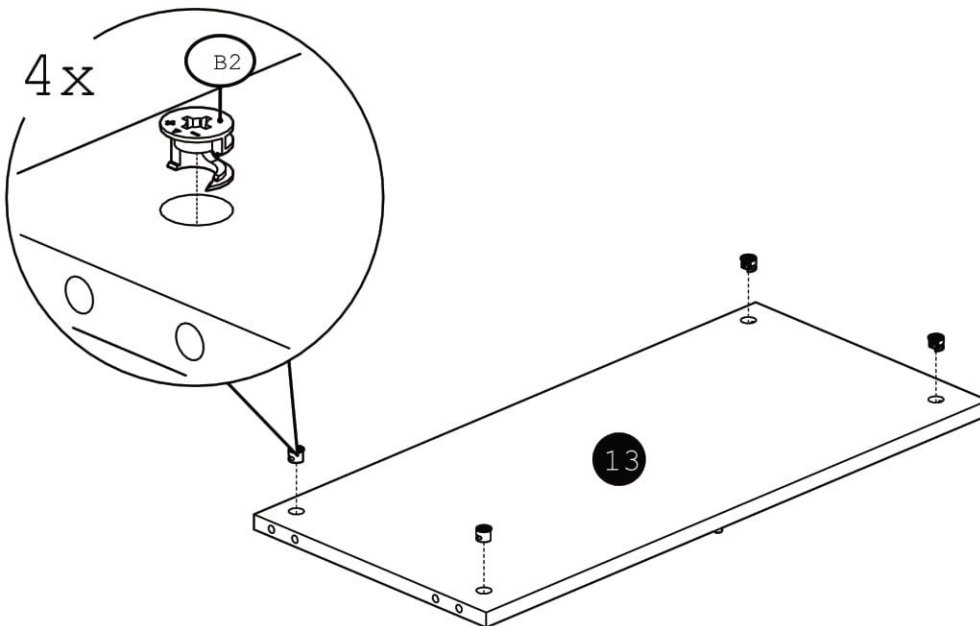
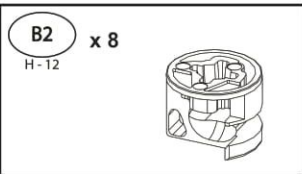

8

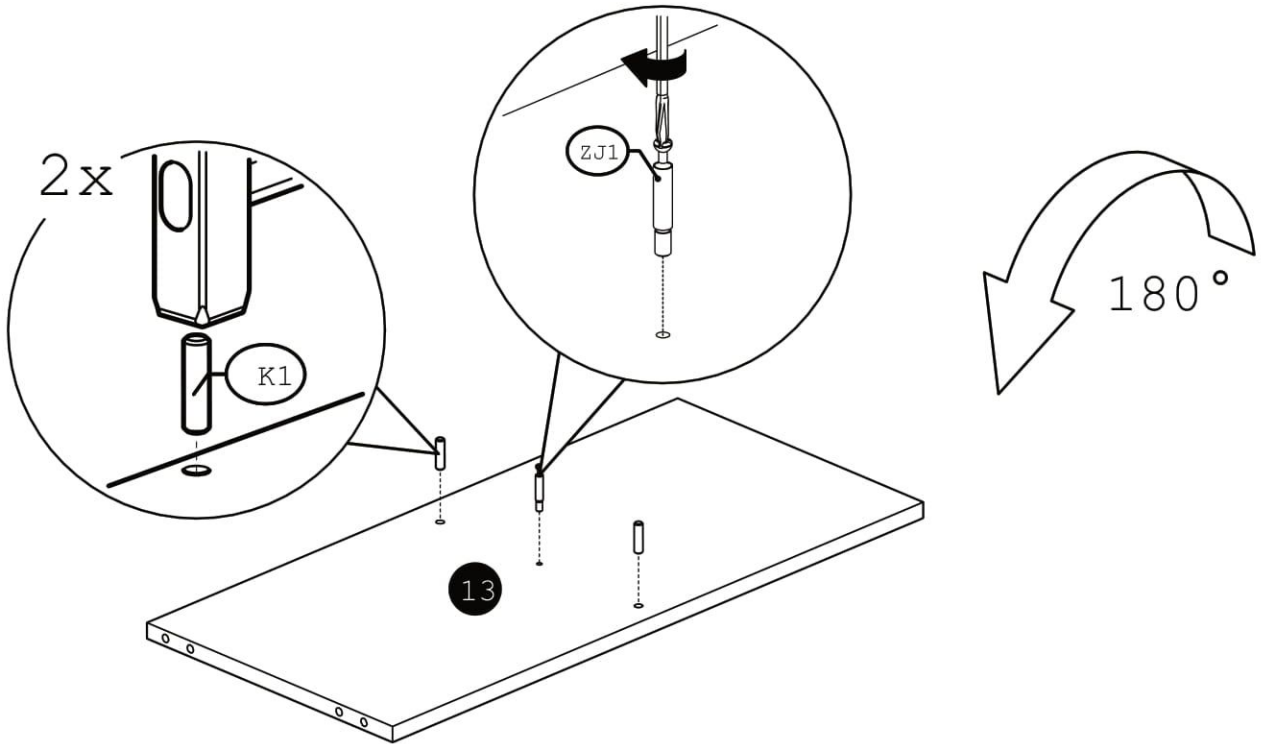
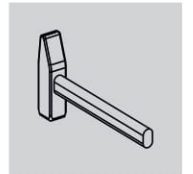
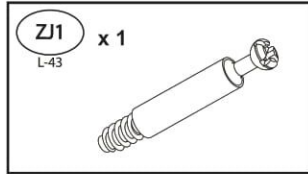
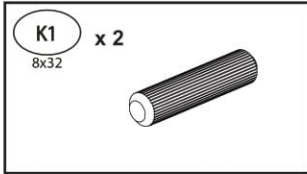

9

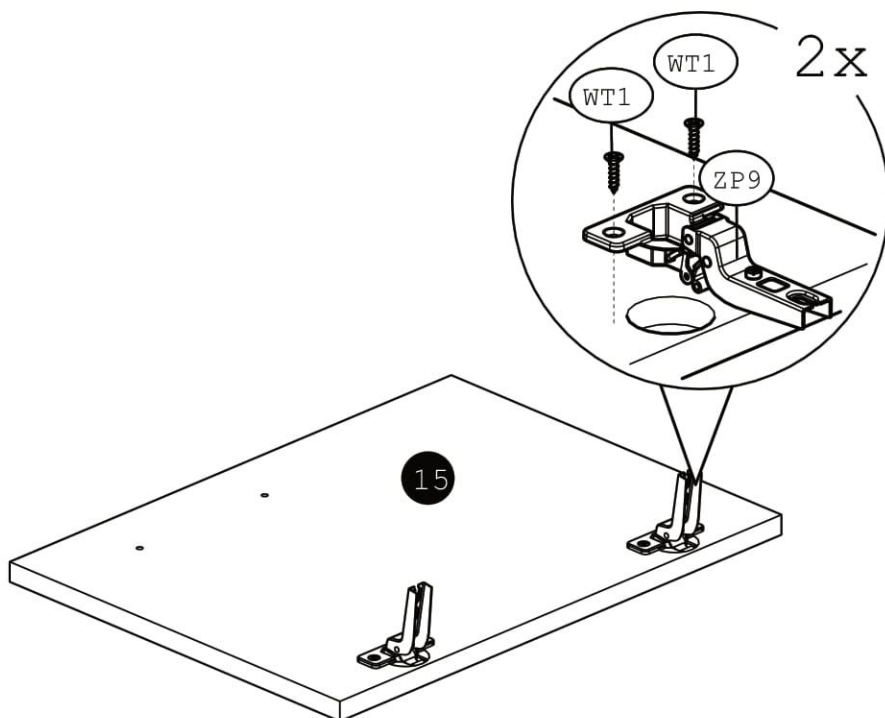
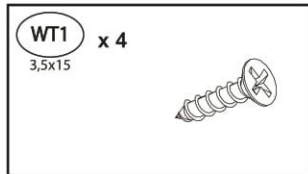
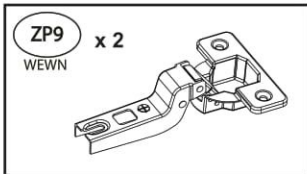

10

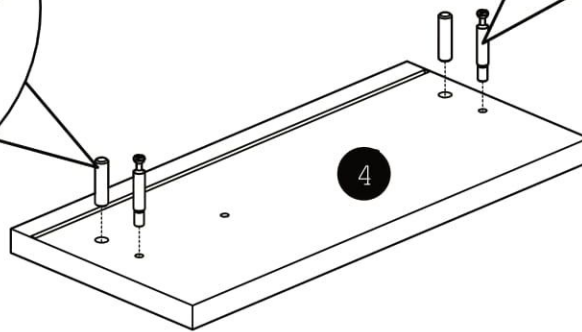
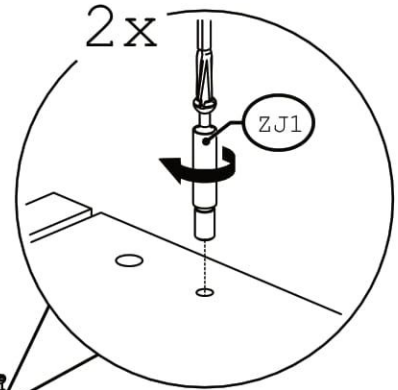
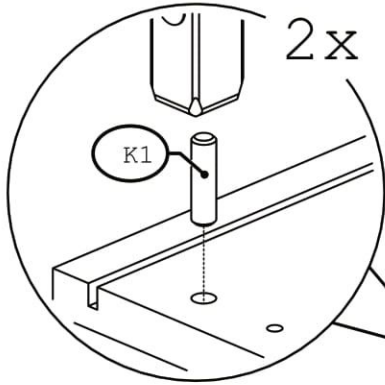
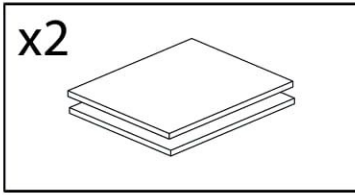
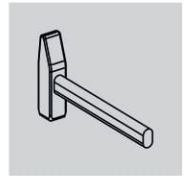
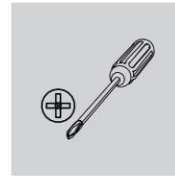
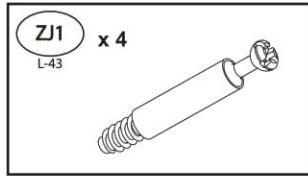
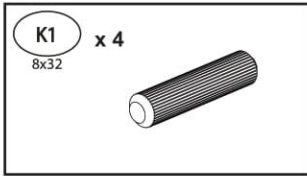

11

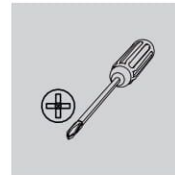

x2

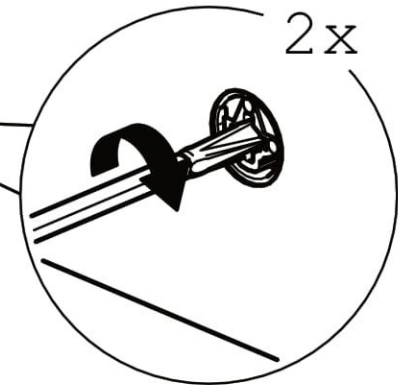
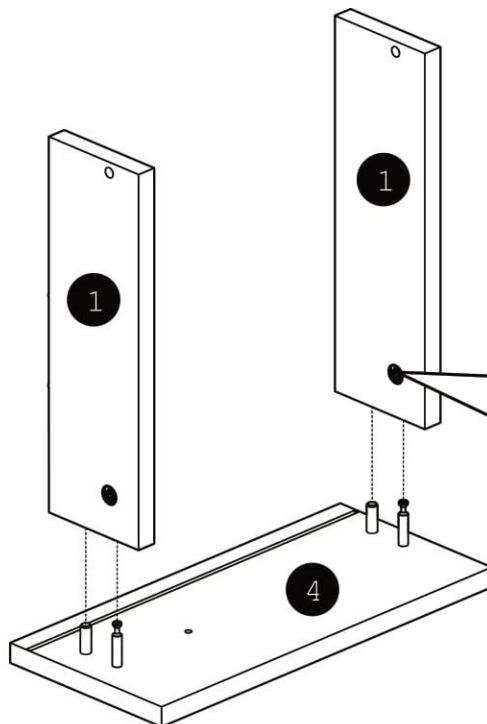

12

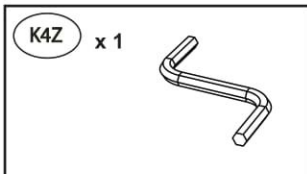
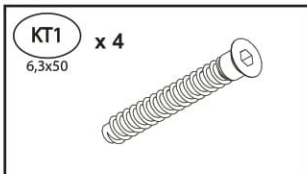

x2

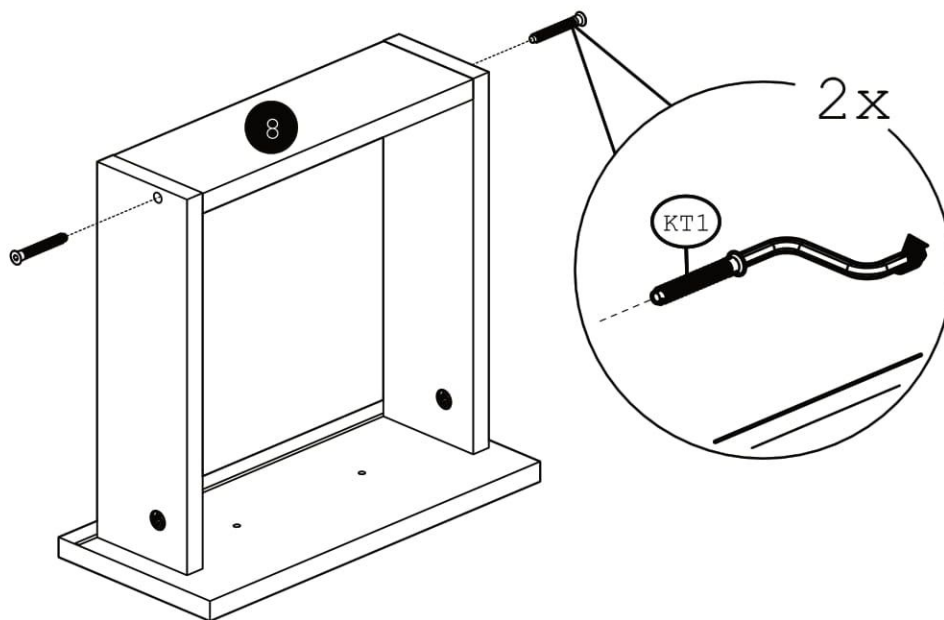

13

x2

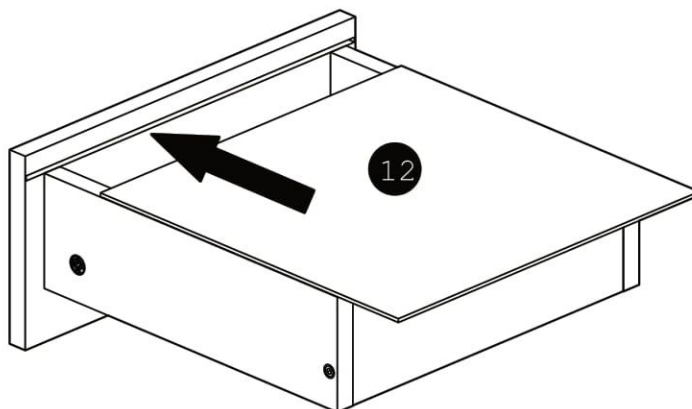
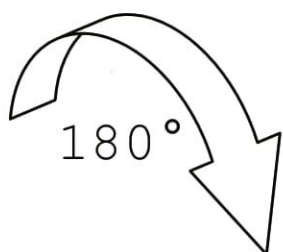

14

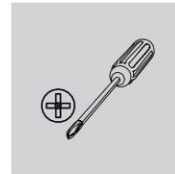
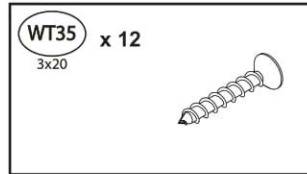
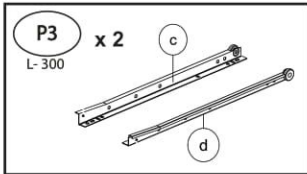

x2

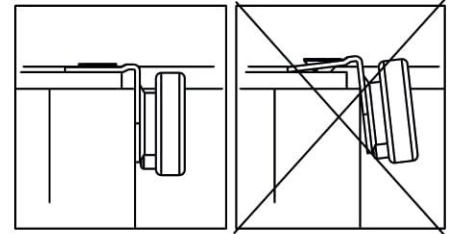
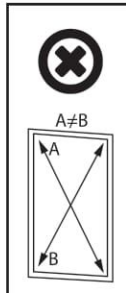
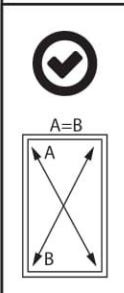
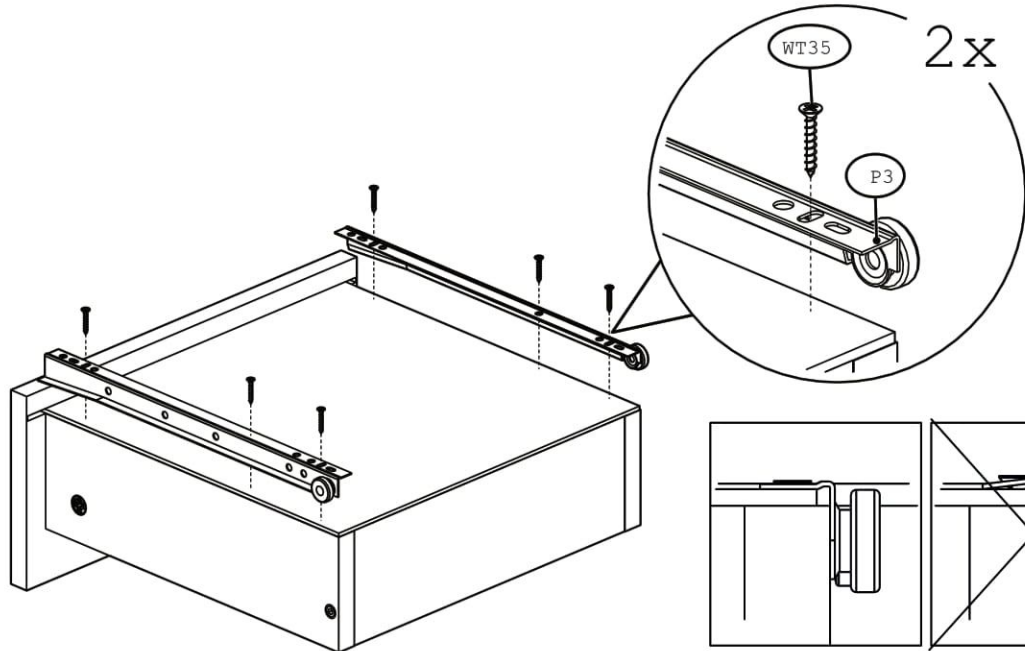

15

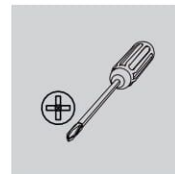
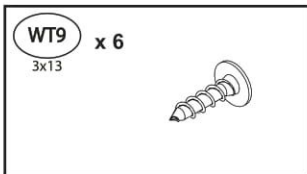

x2

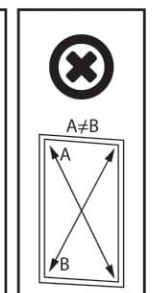
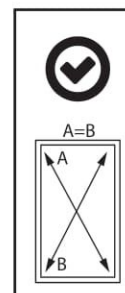
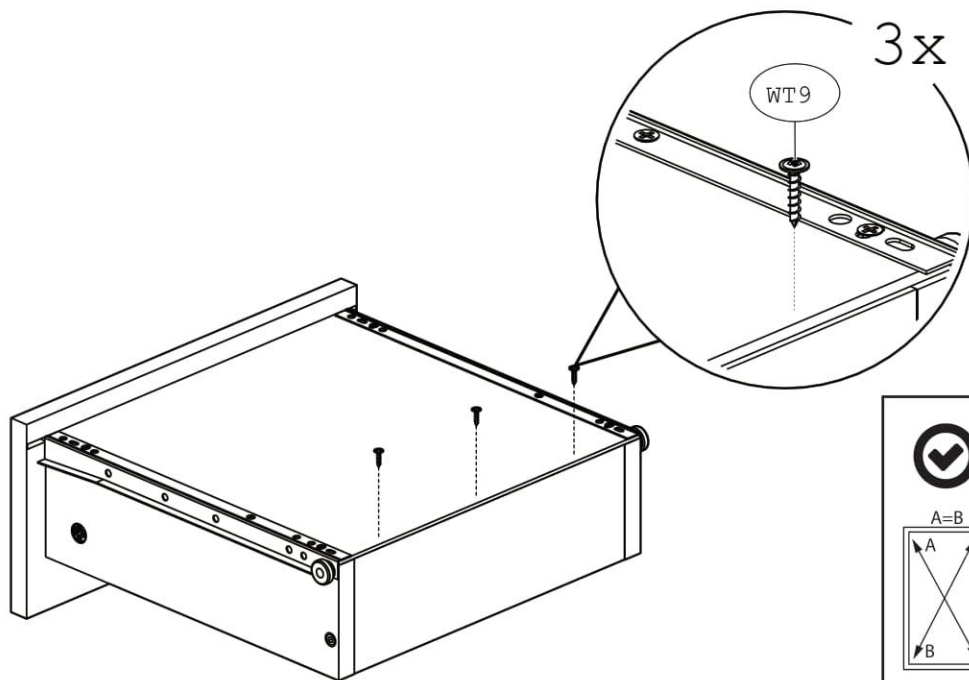

16

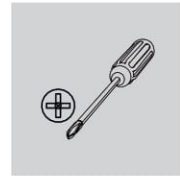
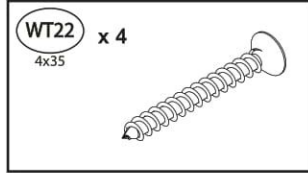
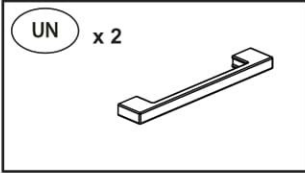

x2

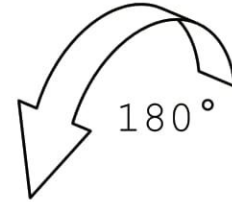
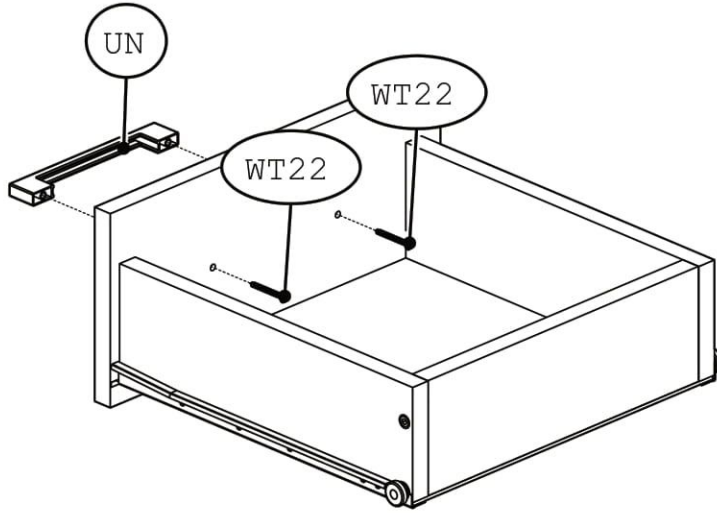

17

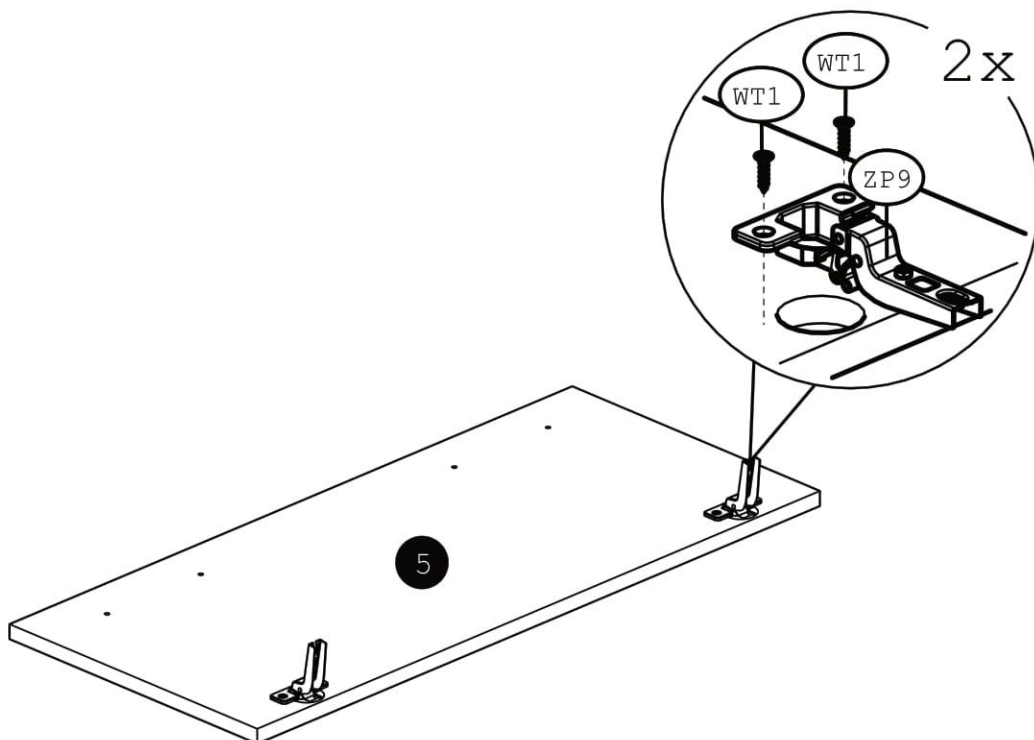
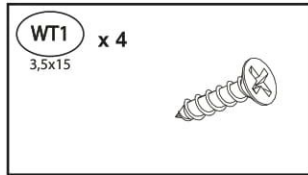
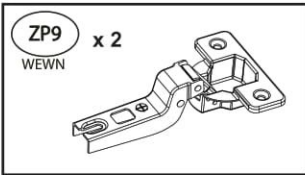

18

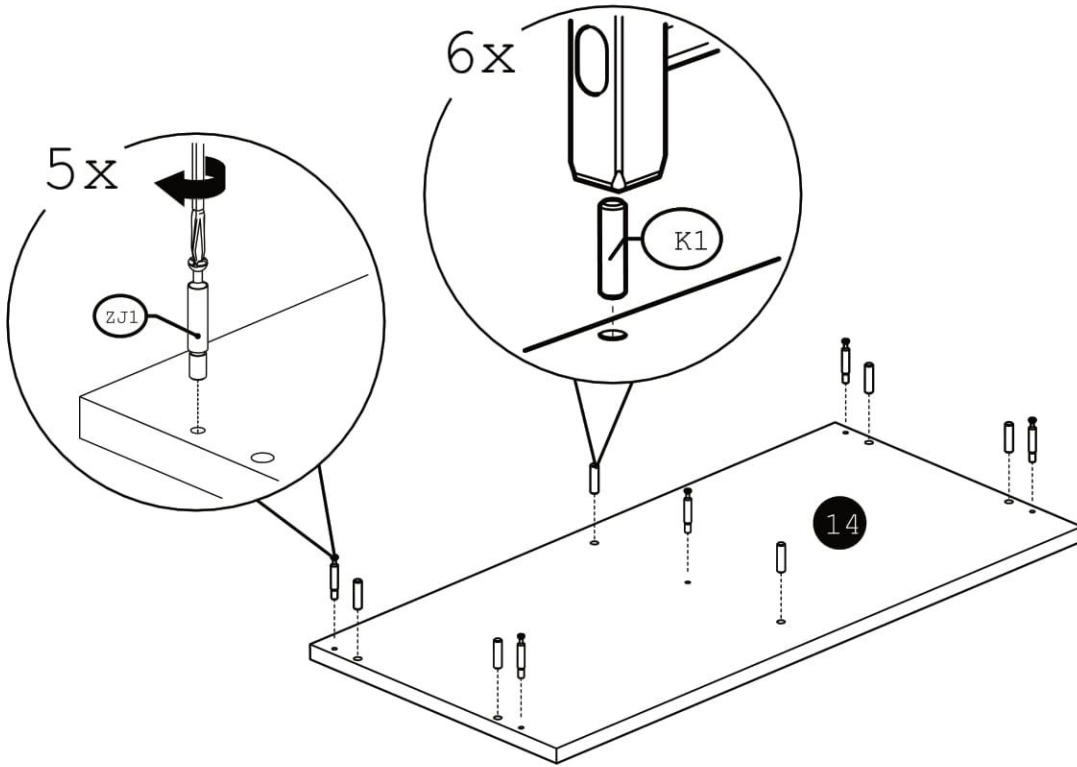
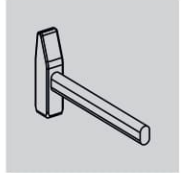
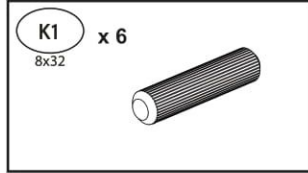
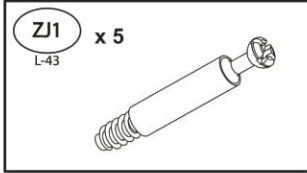

19

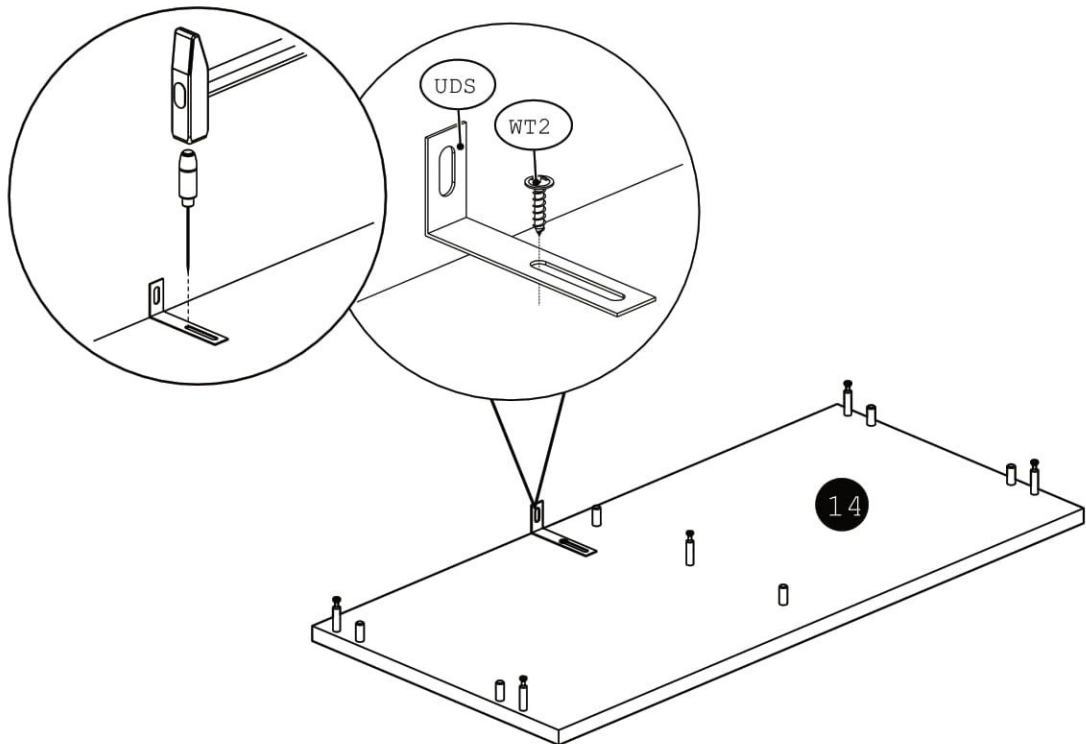
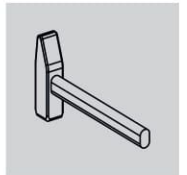
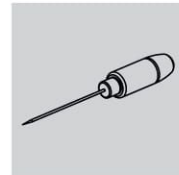
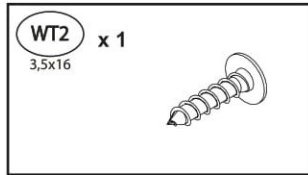
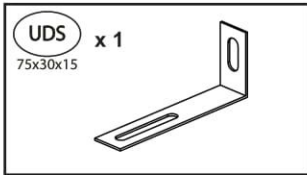

20

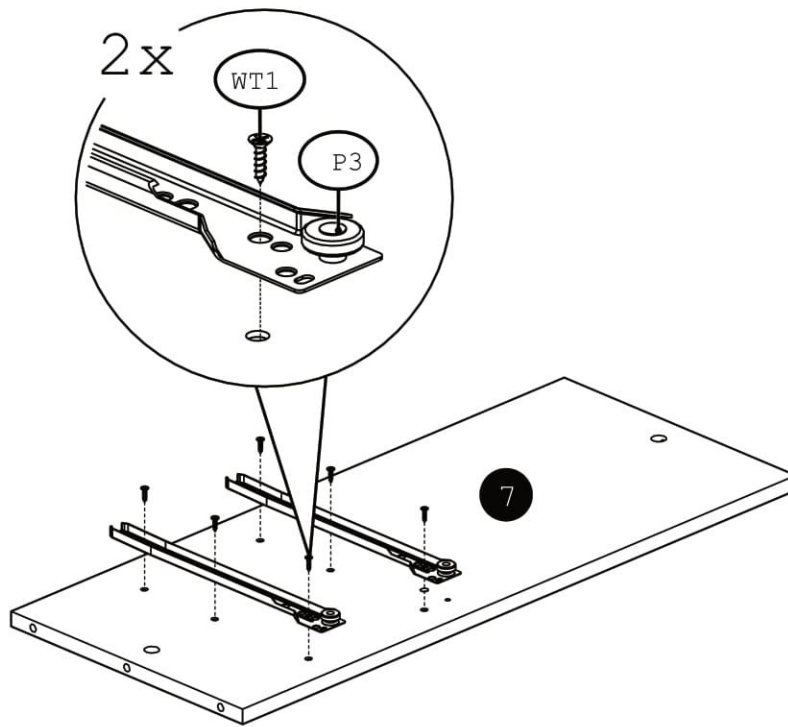
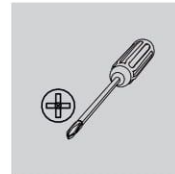
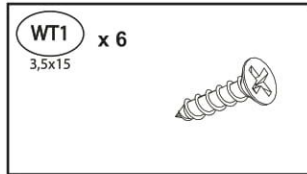
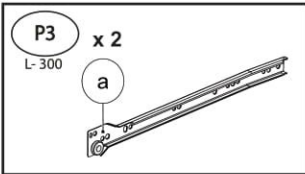

21

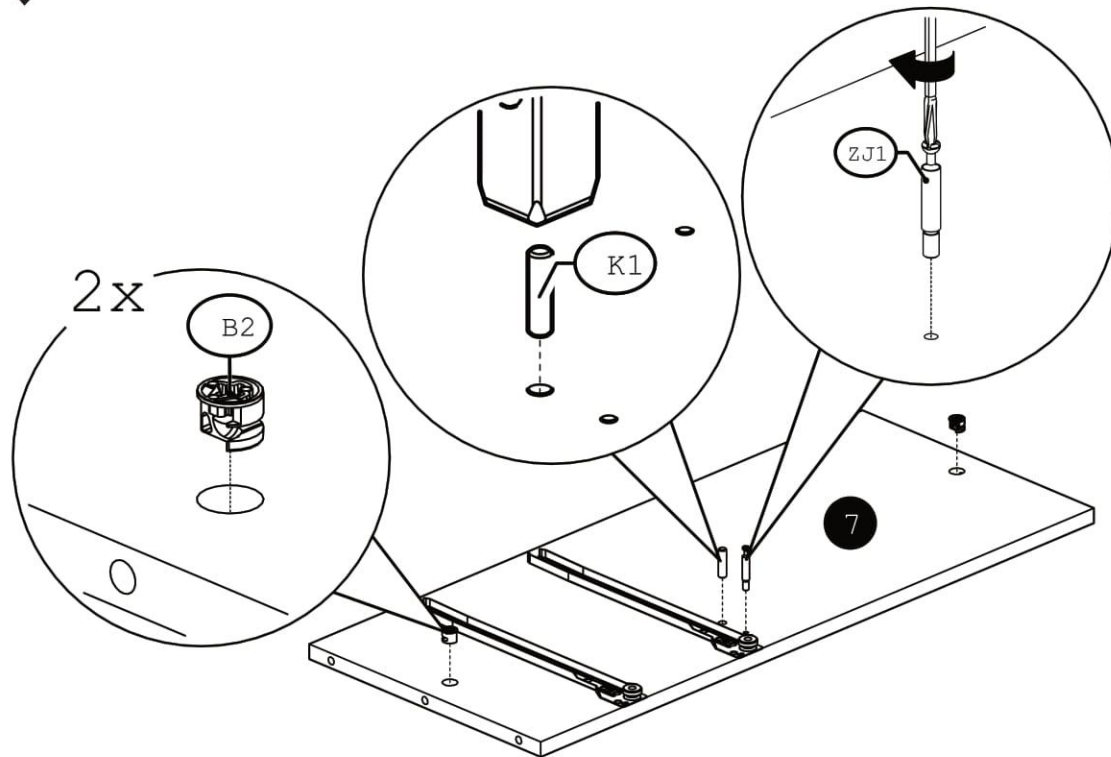
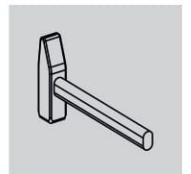
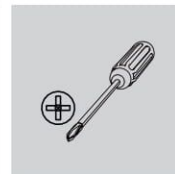
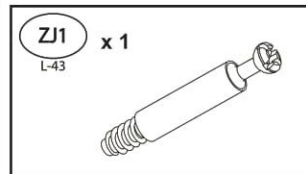
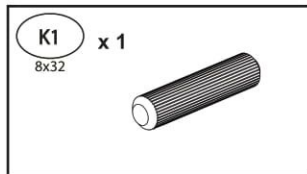
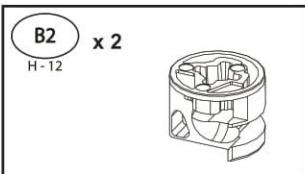

22

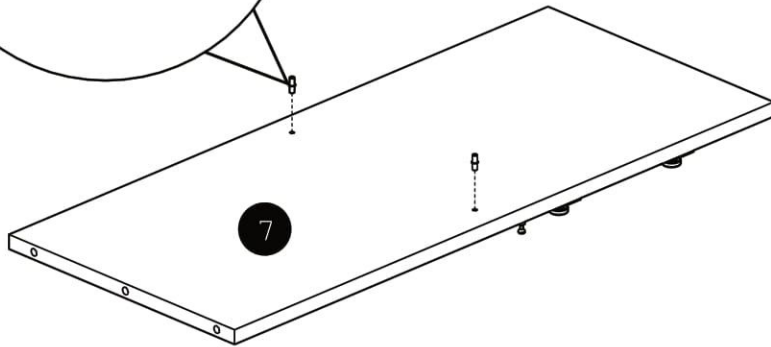
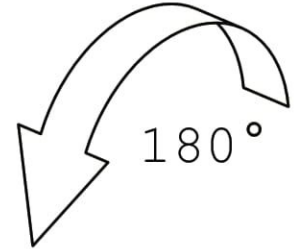
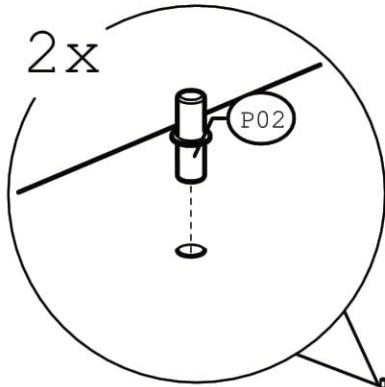
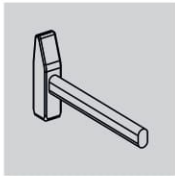
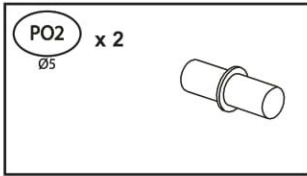

23

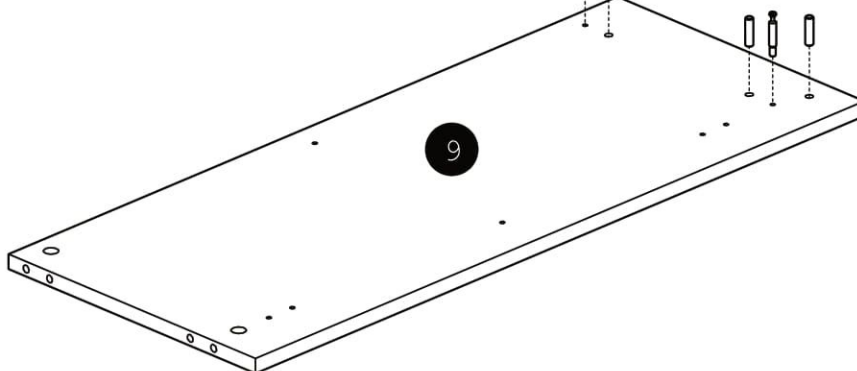
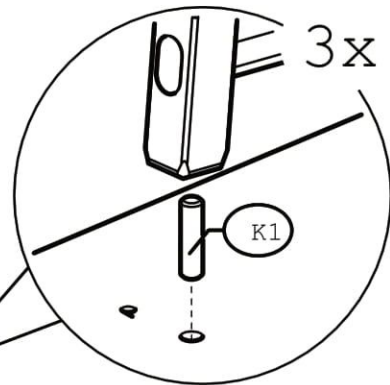
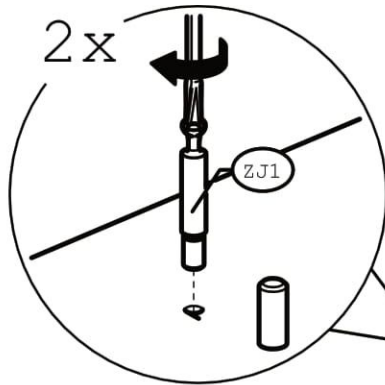
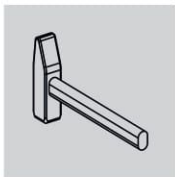
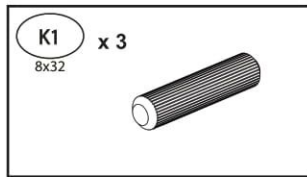
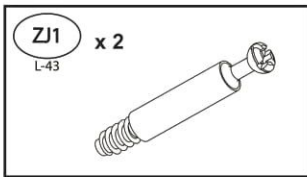

24

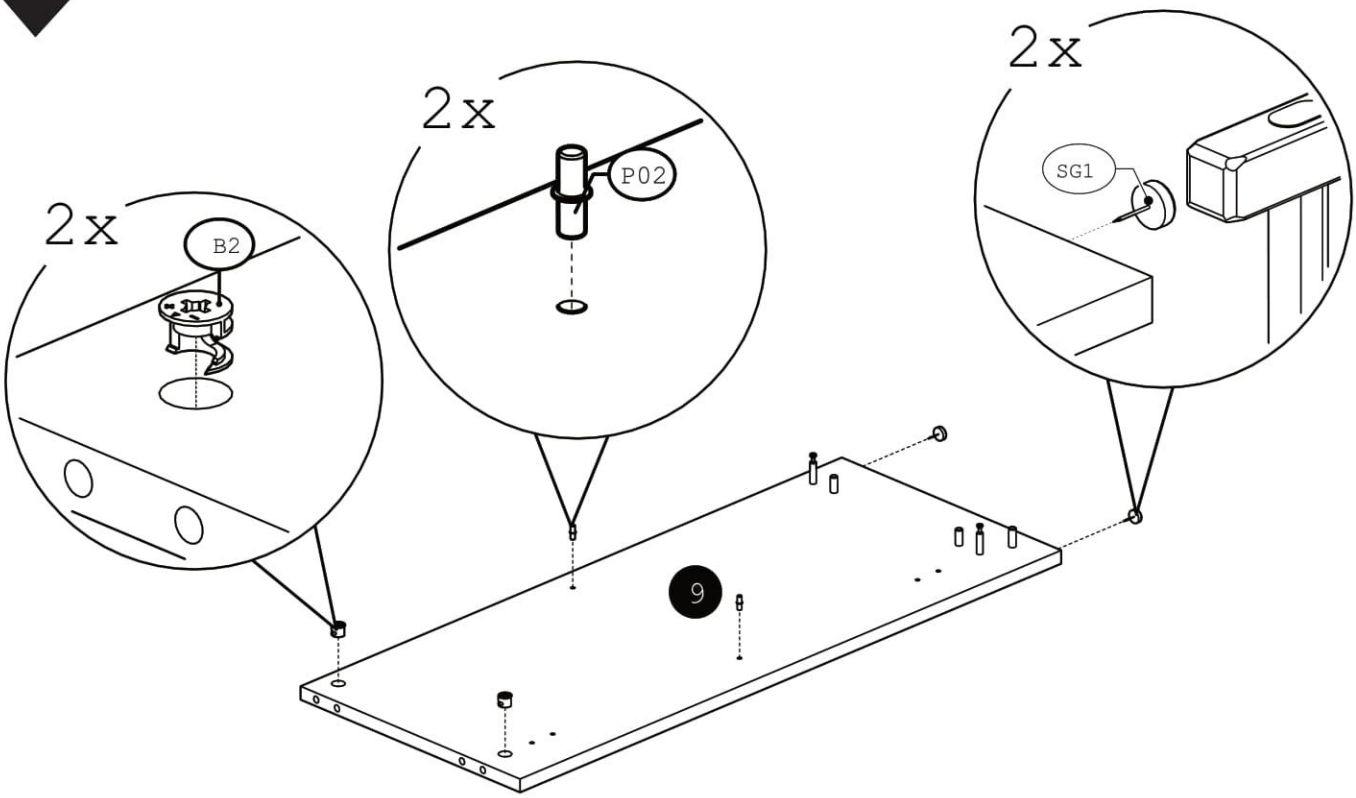
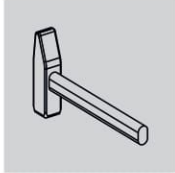
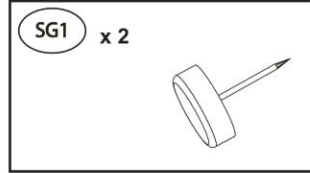
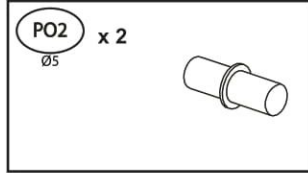
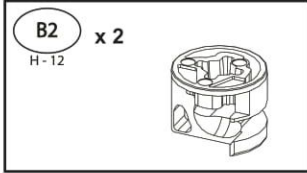

25

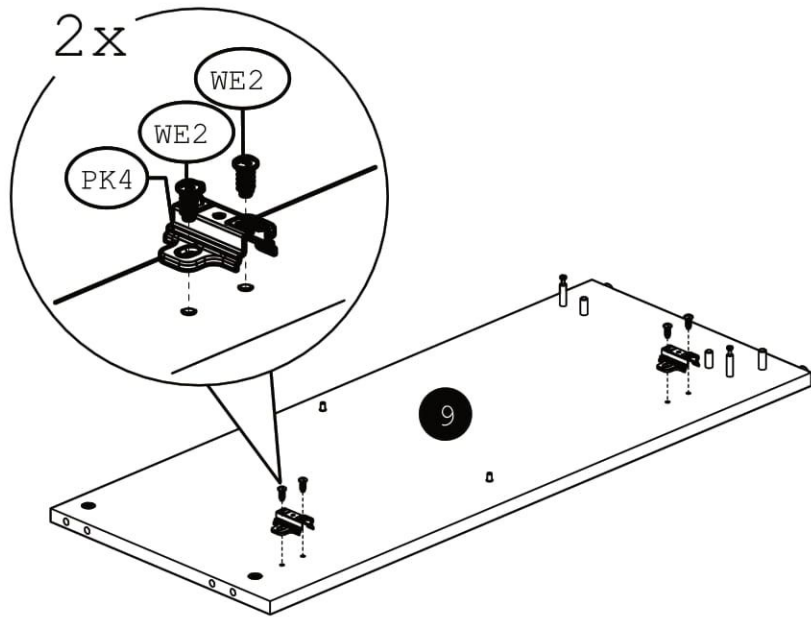
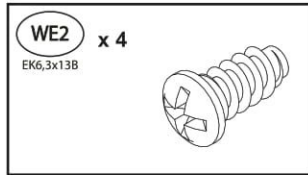
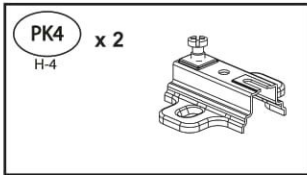

26

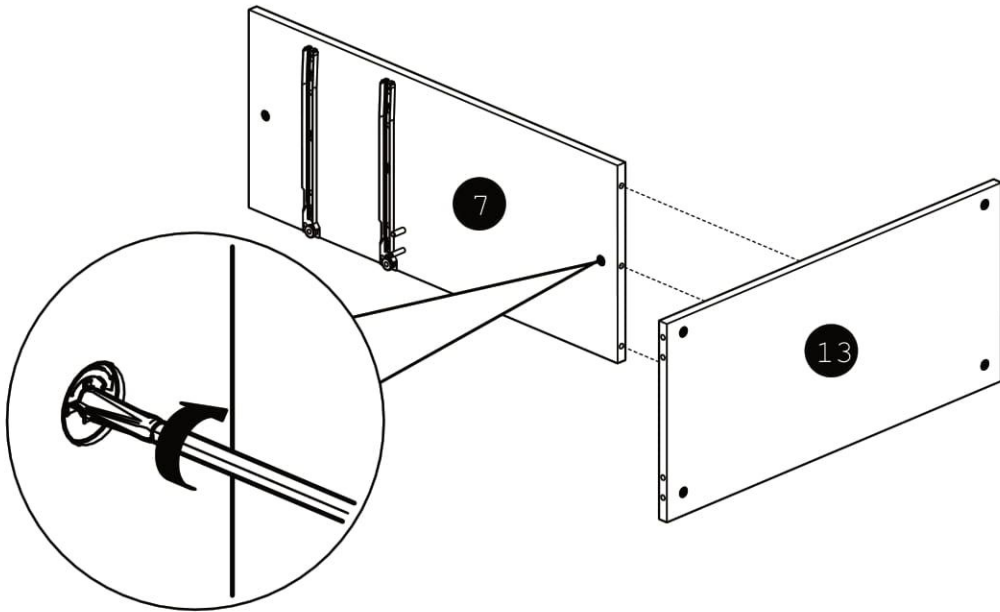

27

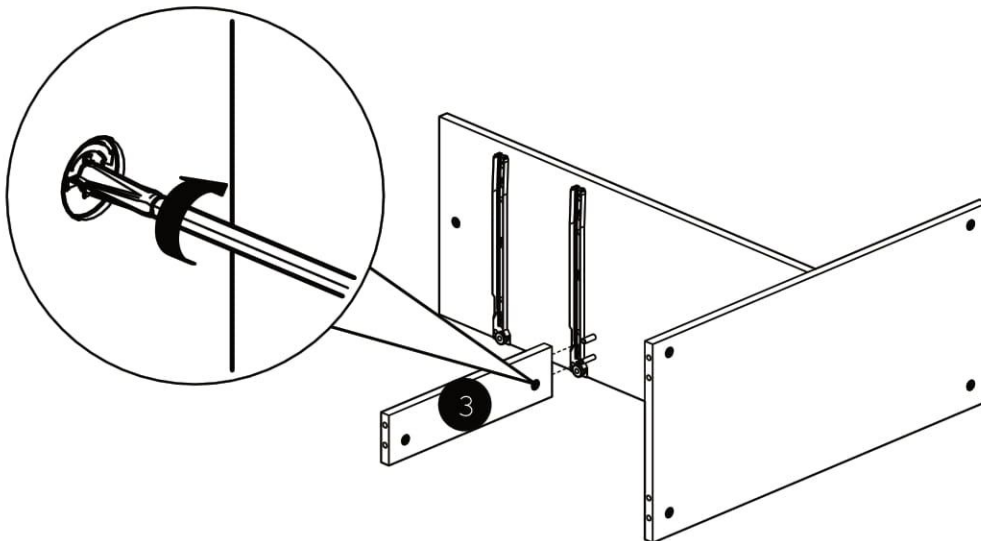

28

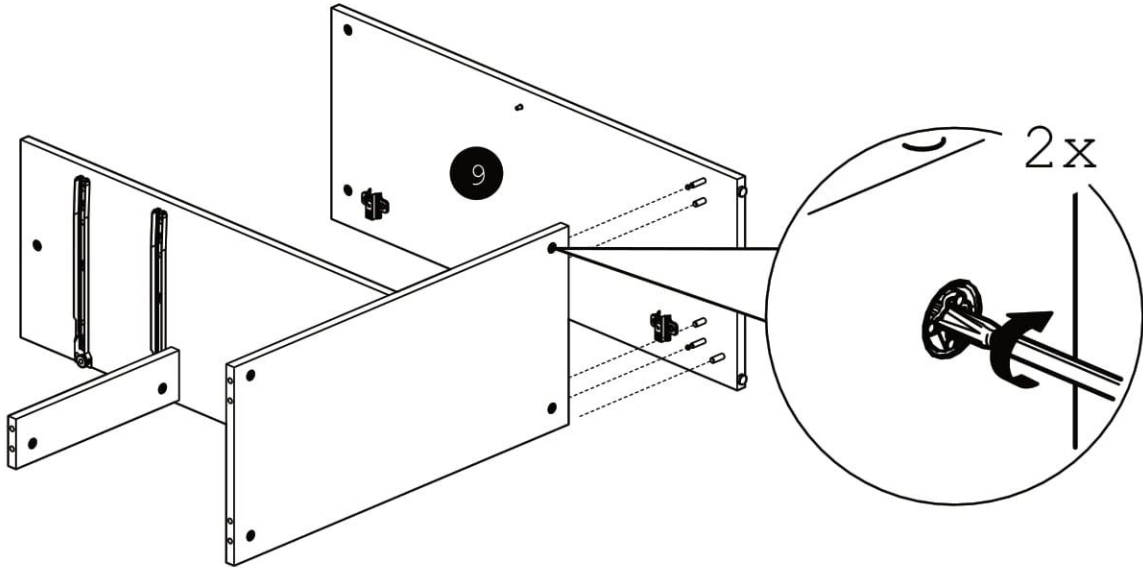
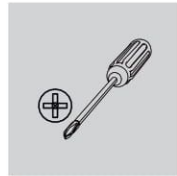

29

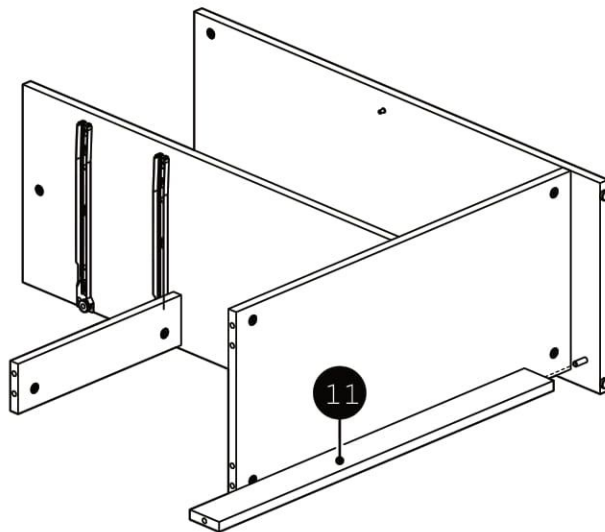

30

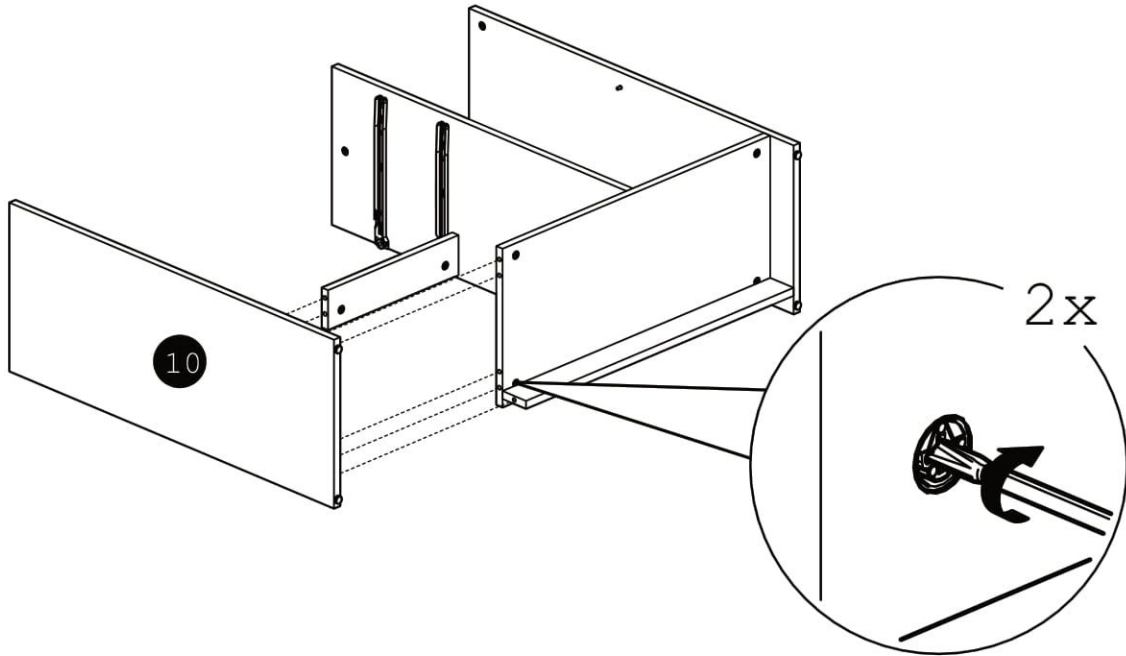

31

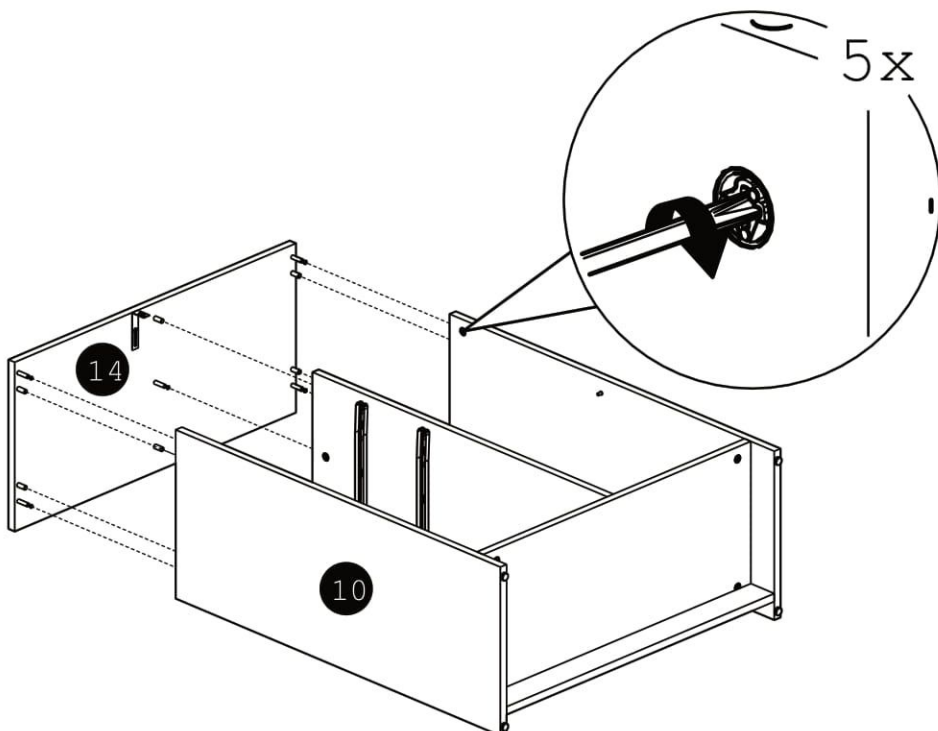

32

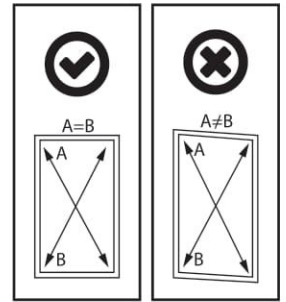
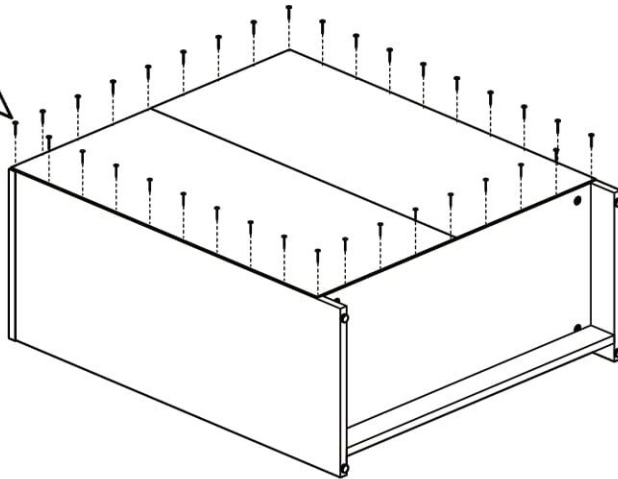
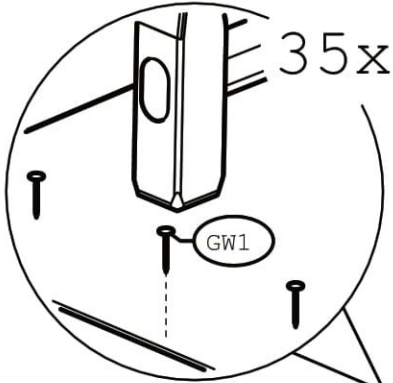
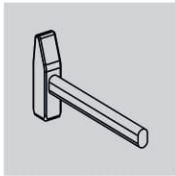
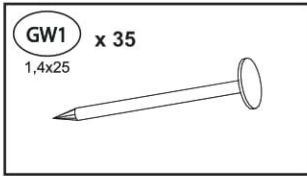

33

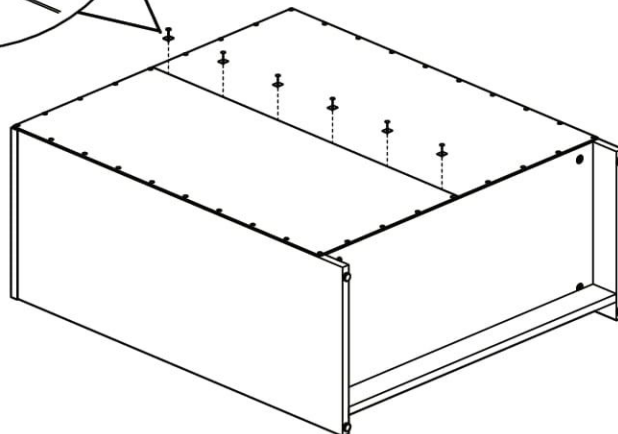
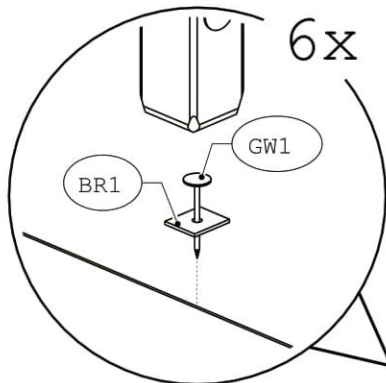
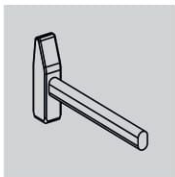
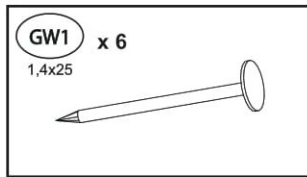
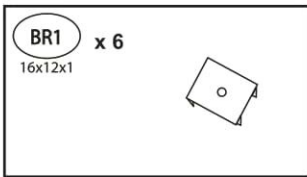

34

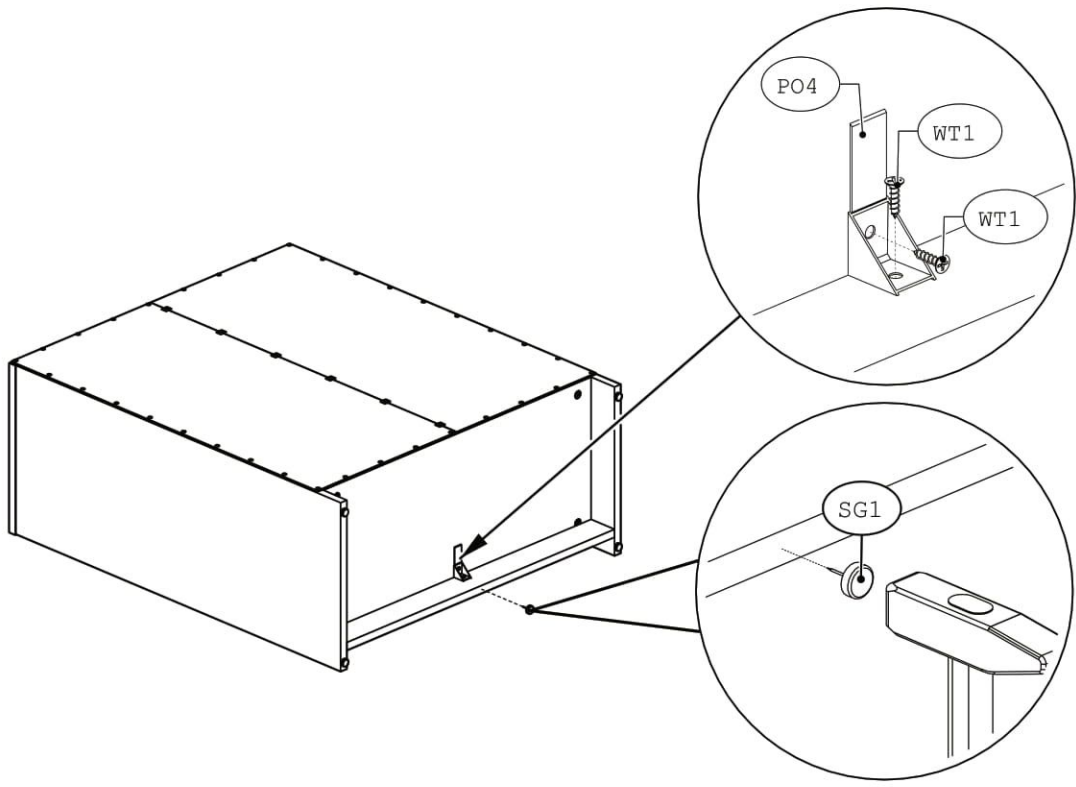
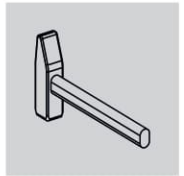
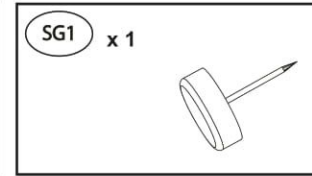
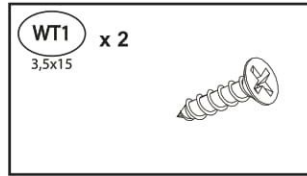
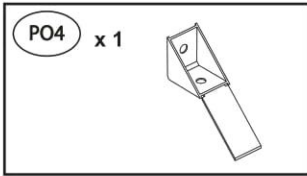

35

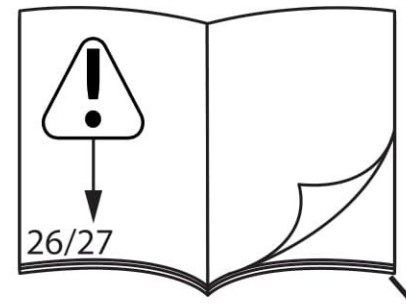
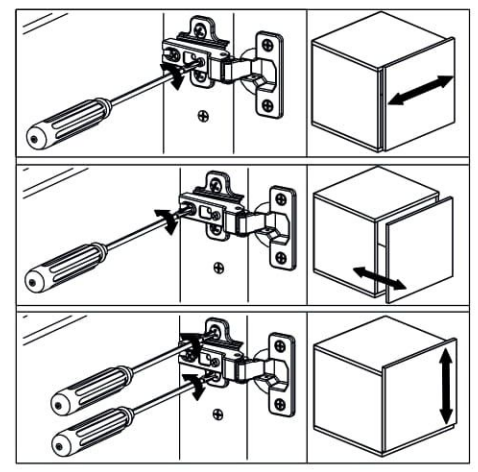
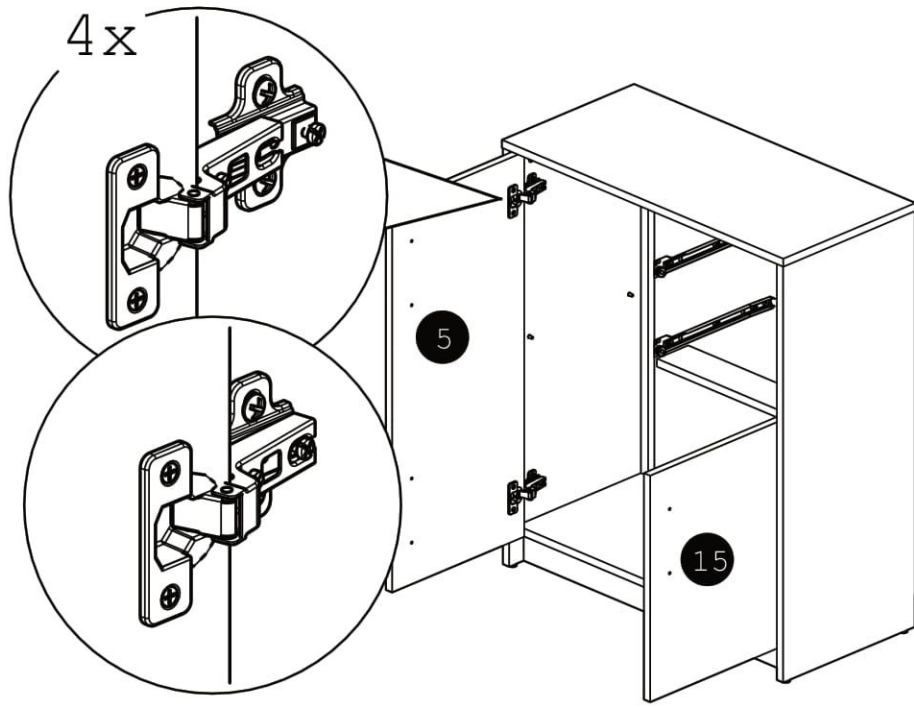



PL –

Przed zawieszeniem mebla, lub przymocowaniem go do ściany, sprawdź wcześniej rodzaj i wytrzymałość ściany. Dobierz odpowiednie kolki i wkręty do rodzaju ściany. W przypadku wątpliwości skontaktuj się ze specjalistą. Montaż musi zostać wykonany przez osobę kompetentną. Instalacja powinna być przeprowadzona zgodnie z instrukcjami producenta – w przeciwnym razie może pojawić się niebezpieczeństwo, że instalacja będzie nieprawidłowa co może spowodować poważne lub śmiertelne obrażenia ciała skutecznego przyniesienia.

OSTRZEŻENIE!!! W celu uniknięcia przewrócenia się tego produktu należy używać go z dołączonym urządzeniem mocowania do ściany. Podczas użytkowania umieszczaj ciężkie przedmioty w dolnej części mebla, nie stawiaj na nim telewizora ani innych ciężkich przedmiotów oraz nigdy nie pozwalaj dzieciom wspinać się na szuflady, drzwiczki i półki.

BG –

Преди да окачите мебелите или да го прикрепите към стената, предварително проверете типа и здравината на стената. Изберете подходящите дюбели и винтове за типа стена. Ако се съмнявате, свържете се със специалист. Монтажът трябва да се извърши от компетентно лице. Монтажът трябва да се извърши в съответствие с инструкциите на производителя - в противен случай може да съществува опасност инсталацията да бъде неправилна, което може да причини сериозни или фатални наранявания поради смачкване.

ВНИМАНИЕ !!! За да избегнете накланянето на този продукт, използвайте го с включеното устройство за закрепване на стената. Когато използвате, поставяйте тежки предмети в долната част на мебелите, не поставяйте телевизора или други тежки предмети върху него и никога не позволявайте на децата да се качват на чекмеджета, врати и рафтове.

CZ –

Před zavěšením nábytku nebo jeho připevněním na zeď si předem ověřte typ a sílu stěny. Vyberte vhodný hmoždinka a šrouby pro typ zdi. V případě pochybností kontaktujte odborníka. Instalace musí být provedena kompetentní osobou. Instalace by měla být provedena v souladu s pokyny výrobce - v opačném případě může existovat nebezpečí, že bude instalace nesprávná, což může v důsledku drčení způsobit vážné nebo smrtelné zranění.

POZOR !!! Chcete-li se vyhnout převrácení tohoto produktu, používejte jej s přiloženým zařízením pro připevnění na zeď. Při používání umístěte těžké předměty do spodní části nábytku, neumísťujte na něj televizor ani jiné těžké předměty a nikdy nedovolte dětem vylézt na zásuvky, dveře a police.

DE –

Bevor Sie die Möbel aufhängen oder an der Wand befestigen, überprüfen Sie vorher den Wandtyp und die Stärke. Wählen Sie die geeigneten Dübel und Schrauben für den Wandtyp. Wenden Sie sich im Zweifelsfall an einen Spezialisten. Die Installation muss von einer kompetenten Person durchgeführt werden. Die Installation sollte gemäß den Anweisungen des Herstellers durchgeführt werden. Andernfalls besteht die Gefahr, dass die Installation falsch ist, was zu schweren oder tödlichen Verletzungen durch Quetschen führen kann.

ACHTUNG !!! Verwenden Sie das mitgelieferte Wan-

dbefestigungsgerät, um ein Umkippen des Produkts zu verhindern. Stellen Sie beim Gebrauch schwere Gegenstände in den Boden der Möbel, stellen Sie den Fernseher oder andere schwere Gegenstände nicht darauf und lassen Sie Kinder niemals auf Schubladen, Türen und Regale klettern.

EN –

Before hanging the furniture or attaching it to the wall, check the wall type and strength beforehand. Choose the appropriate dowels and screws for the wall type. If in doubt, contact a specialist. Installation must be carried out by a competent person. The installation should be carried out in accordance with the manufacturer's instructions - otherwise there may be a danger that the installation will be incorrect, which can cause serious or fatal injury due to crushing.

WARNING!!! To prevent the product from tipping over, use it with the wall attachment device included. When using, place heavy objects on the bottom of the furniture, do not place the TV or other heavy objects on it, and never allow children to climb on drawers, doors and shelves.

ES –

Antes de colgar los muebles o pegarlos a la pared, verifique el tipo de pared y la resistencia de antemano. Elija los tacos y tornillos adecuados para el tipo de pared. En caso de duda, contacte a un especialista. La instalación debe ser realizada por una persona competente. La instalación debe llevarse a cabo de acuerdo con las instrucciones del fabricante; de lo contrario, puede existir el peligro de que la instalación sea incorrecta, lo que puede causar lesiones graves o fatales debido al aplastamiento.

ADVERTENCIA !!! Para evitar que el producto se vuelque, úselo con el dispositivo de fijación a la pared incluido. Cuando lo use, coloque objetos pesados en la parte inferior de los muebles, no coloque el televisor u otros objetos pesados sobre él, y nunca permita que los niños se suban a los cajones, puertas y estantes.

EST –

Enne mööbli riputamist või seina külge kinnitamist kontrollige eelnevalt seina tüüpi ja tugevust. Valige seinatüübile sobivad tüübliid ja kruvid. Kahtluse korral pöörduge spetsialisti poole. Paigaldamise peab läbi viima pädev isik. Paigaldamine peaks toimuma vastavalt tootja juhistele - vastasel juhul võib olla oht, et paigaldus on vale, mis võib muljumise tagajärjel põhjustada tõsiseid või surmavaid vigastusi.

HOIATUS !!! Toote ümbermineku vältimiseks kasutage seda koos seinale kinnitatava seadmega. Kasutades asetage mööbli põhja raskeid esemeid, ärge asetage telerit ega muid raskeid esemeid selle peale ega tohi kunagi laskuda sahtlitele, ustele ja riiliteele.

FR –

Avant de suspendre le meuble ou de le fixer au mur, vérifiez au préalable le type et la résistance du mur. Choisissez les chevilles et vis appropriées pour le type de mur. En cas de doute, contactez un spécialiste. L'installation doit être effectuée par une personne compétente. L'installation doit être effectuée conformément aux instructions du fabricant - sinon il peut y avoir un risque que l'installation soit incorrecte, ce qui peut provoquer des blessures graves ou mortelles en raison de l'écrasement.

ATTENTION !!! Pour éviter que le produit ne bascule, utilisez-le avec le dispositif de fixation murale inclus. Lors de l'utilisation, placez des objets lourds au fond du meuble, ne placez pas le téléviseur ou d'autres objets lourds dessus et ne laissez jamais les enfants grimper sur les tiroirs, les portes et les étagères.

HR –

Prije nego što objesite namještaj ili ga pričvrstite na zid, prije toga provjerite vrstu i čvrstoću zida. Odberite odgovarajuće tipove i vijke za vrstu zida. Ako imate dvojbe, obratite se stručnjaku. Ugradnju mora

izvesti stručna osoba. Ugradnju treba izvesti u skladu s uputama proizvođača - u protivnom može postojati opasnost da instalacija bude neispravna, što može uzrokovati ozbiljne ili smrtne ozljede uslijed drobljenja.

UPOZORENJE !!! Da biste izbjegli prevrtanje uređaja, koristite ga s priloženim uređajem za pričvršćivanje na zid. Kad koristite, teške predmete stavite na dno namještaja. Ne stavljajte televizor ili druge teške predmete na njega i nikada nemojte dopustiti djeci da se penju na ladice, vrata i police.

HU –

A bútorok felfüggesztése vagy a falhoz rögzítése előtt ellenőrizze a fal típusát és szilárdságát. Válassza ki a falhoz megfelelő csapokat és csavarokat. Ha kétségei vannak, forduljon szakemberhez. A beszerelést illetékes személynek kell elvégeznie. A beszerelést a gyártó utasításainak megfelelően kell elvégezni - különben fennáll annak a veszélye, hogy a beszerelés helytelen lesz, ami komoly vagy halálos sérüléseket okozhat a zúzás miatt.

FIGYELEM !!! A termék leborulásának elkerülése érdekében használna a mellékelt fali rögzítőberendezéssel. Használat közben tegyen nehéz tárgyakat a bútor aljára, ne tegye a televíziót vagy más nehéz tárgyakat, és soha ne engedje, hogy a gyermekek fiókokon, ajtókn vagy polcon mászzanak fel.

I –

Prima di appendere i mobili o di attaccarli al muro, verificare in anticipo il tipo e la resistenza del muro. Scegli i tasselli e le viti appropriati per il tipo di muro. In caso di dubbi, contattare uno specialista. L'installazione deve essere eseguita da una persona competente. L'installazione deve essere eseguita secondo le istruzioni del produttore, altrimenti potrebbe esserci il pericolo che l'installazione non sia corretta, con conseguenti lesioni gravi o mortali dovute a schiacciamento.

ATTENZIONE !!! Per evitare il ribaltamento del prodotto, utilizzarlo con il dispositivo di fissaggio a parete incluso. Durante l'uso, posizionare oggetti pesanti nella parte inferiore dei mobili, non posizionare la TV o altri oggetti pesanti su di esso e non consentire ai bambini di arrampicarsi su cassetti, porte e scaffali.

LV –

Pirms mēbeļu pakarināšanas vai piestiprināšanas pie sienas, iepriekš pārbaudiet sienas veidu un stiprību. Izvēlieties sienas tipam atbilstošos dibeljus un skrūves. Ja rodas šaubas, sazinieties ar speciālistu. Uzstādīšana jāveic kompetentai personai. Uzstādīšana jāveic saskaņā ar ražotāja norādījumiem - pretējā gadījumā var būt risks, ka uzstādīšana būs nepareiza, kas saspiešanas dēļ var izraisīt nopietnus vai nāvējošus savainojumus.

BRĪDINĀJUMS !!! Lai izvairītos no šī produkta apgāšanās, izmantojiet to kopā ar sienas stiprināšanas ierīci. Lietojot, novietojiet smagus priekšmetus mēbeļu apakšā, nelieciet televizoru vai citus smagus priekšmetus un nekad neļaujiet bērniem kāpt uz atvilktnēm, durvīm un plauktiem.

LT –

Prieš pakabindami baldus ar pritvirtindami juos prie sienos, prieš tai patikrinkite sienų tipą ir stiprumą. Pasirinkite tinkamus sienos tipui kaiščius ir varžtus. Jei kyla abejonių, susisiekite su specialistu. Montavimą turi atlikti kompetentingas asmuo. Montavimas turėtų būti atliekamas pagal gamintojo instrukcijas - priešingu atveju gali kilti pavojus, kad montavimas bus neteisingas, o dėl sutraikymo gali būti padaryta rimta ar mirtina žala.

DĖMESIO !!! Norėdami išvengti gaminio apvirtimo, naudokite jį kartu su sieninio tvirtinimo įtaisu. Kai naudojate, įdėkite sunkius daiktus į baldų dugną, nedėkite televizoriaus ar kitų sunkių daiktų ant jo ir niekada neleiskite vaikams lipti ant stalčių, durų ir lentynų.

NL –
Voordat u het meubel ophangt of aan de muur bevestigt, moet u vooraf het muurtype en de sterkte controleren. Kies de juiste pluggen en schroeven voor het wandtype. Neem bij twijfel contact op met een specialist. De installatie moet worden uitgevoerd door een bevoegd persoon. De installatie moet worden uitgevoerd in overeenstemming met de instructies van de fabrikant - anders bestaat het gevaar dat de installatie onjuist is, wat ernstig of dodelijk letsel door beknelling kan veroorzaken.

LET OP !!! Om te voorkomen dat dit product omvalt, gebruikt u het met het meegeleverde muurbevestigingsapparaat. Plaats tijdens gebruik zware voorwerpen onder in het meubel, plaats de tv of andere zware voorwerpen er niet op en laat kinderen nooit op laden, deuren en planken klimmen.

P –
Antes de pendurar os móveis ou anexá-los à parede, verifique o tipo e a resistência da parede com antecedência. Escolha as cavilhas e parafusos apropriados para o tipo de parede. Em caso de dúvida, entre em contato com um especialista. A instalação deve ser realizada por uma pessoa competente. A instalação deve ser realizada de acordo com as instruções do fabricante - caso contrário, pode haver um risco de que a instalação esteja incorreta, o que pode causar ferimentos graves ou fatais devido ao esmagamento. ATENÇÃO !!! Para evitar que o produto tombe, use-o com o dispositivo de fixação na parede incluído. Ao usar, coloque objetos pesados na parte inferior dos móveis, não coloque a TV ou outros objetos pesados sobre ela e nunca permita que crianças subam em gavetas, portas e prateleiras.

RO –
Înainte de a agăta mobilierul sau de a-l fixa pe perete, verificați în prealabil tipul și rezistența peretelui. Alegeți diblurile și șuruburile potrivite pentru tipul de perete. Dacă aveți îndoieli, contactați un specialist. Instalarea trebuie efectuată de o persoană competentă. Instalarea trebuie efectuată în conformitate cu instrucțiunile producătorului - altfel poate exista pericolul ca instalația să fie incorectă, ceea ce poate provoca vătămări grave sau fatale din cauza zdrobirii. ATENȚIE !!! Pentru a preveni răsturnarea produsului, folosiți-l cu dispozitivul de fixare pe perete inclus. Când folosiți, așezați obiecte grele în fundul mobilierului, nu așezați televizorul sau alte obiecte grele pe el și nu lăsați niciodată copiii să urce pe sertare, uși și rafturi.

RU –
Прежде чем повесить мебель или прикрепить ее к стене, заранее проверьте тип и прочность стены. Выберите соответствующие дюбели и винты для типа стены. В случае сомнений обратитесь к специалисту. Установка должна выполняться компетентным лицом. Установка должна выполняться в соответствии с инструкциями производителя - в противном случае может возникнуть опасность, что установка будет неправильной, что может привести к серьезным или смертельным травмам из-за повреждения. ВНИМАНИЕ !!! Чтобы предотвратить опрокидывание изделия, используйте его с прилагаемым настенным крепежным устройством. При использовании кладите тяжелые предметы на дно мебели, не ставьте на него телевизор или другие тяжелые предметы и никогда не позволяйте детям лезть на ящики, двери и полки.

S –
Innan du hänger möblerna eller fäster dem på väggen, ska du kontrollera väggtyp och styrka i förväg. Välj lämpliga stift och skruvar för väggtypen. Om du är osäker, kontakta en specialist. Installation måste utföras av en behörig person. Installationen ska utföras

i enlighet med tillverkarens anvisningar - annars kan det vara en risk att installationen blir felaktig, vilket kan orsaka allvarlig eller dödlig skada på grund av krossning.

VARNING !!! För att undvika att produkten tippas, använd den med den medföljande väggfästeenheter. När du använder, placera tunga föremål i botten av möblerna, placera inte TV: n eller andra tunga föremål på den och låt aldrig barn klättra på lådor, dörrar och hyllor.

SK –
Pred zavesením nábytku alebo jeho pripevnením na stenu si najprv overte druh a silu steny. Vyberte vhodný hmoždinky a skrutky pre daný typ steny. V prípade pochybností kontaktujte odborníka. Inštaláciu musí vykonať kompetentná osoba. Inštalácia by sa mala vykonať v súlade s pokynmi výrobcu - v opačnom prípade môže existovať nebezpečenstvo, že inštalácia bude nesprávna, čo môže v dôsledku rozdrvenia spôsobiť vážne alebo smrteľné zranenie.

POZOR !!! Aby ste zabránili prevráteniu produktu, používajte ho s priloženým pripevňovacím zariadením na stenu. Pri používaní umiestnite ťažké predmety do spodnej časti nábytku, neumiestňujte naň televízor ani iné ťažké predmety a nikdy nedovoľte deťom vyliezť na zásuvky, dvere a police.

SLO –
Preden obesite pohištvo ali ga pritrdite na steno, predhodno preverite vrsto in trdnost stene. Izberite ustrezne moznike in vijake za vrsto stene. Če dvomite, se obrnite na strokovnjaka. Montažo mora izvesti pristojna oseba. Namestitev je treba izvesti v skladu z navodili proizvajalca - v nasprotnem primeru lahko obstaja nevarnost napačne namestitve, kar lahko zaradi drobljenja povzroči resne ali smrtne poškodbe. OPOZORILO !!! Da se izognete prevračanju tega izdelka, ga uporabljajte s priloženo pritrdilno napravo za steno. Pri uporabi položite težke predmete na dno pohištva, ne postavljajte televizorja ali drugih težkih predmetov nanj in otrokom nikoli ne dovolite, da se vzpenjajo po predalih, vratih in policah.

SRB –
Пре него што објесите намјештај или га причврстите на зид, претходно проверите врсту и чврстоћу зида. Одаберите одговарајуће типове и вијке за тип зида. Ако имате сумње, обратите се стручњаку. Инсталацију мора извести компетентна особа. Инсталацију треба извести у складу са упутствима произвођача - у супротном може постојати опасност да инсталација буде неисправна, што може узроковати озбиљне или смртне повреде услед дробљења. УПОЗОРЕЊЕ !!! Да бисте избегли превртање уређаја, користите га са приложеним уређајем за причвршћивање на зид. Када користите, тешке предмете ставите у дно намештаја, не стављајте телевизор или друге тешке предмете на њега и никада не дозволите деци да се пењу на фиоке, врата и полице.

TR –
Mobilyaları asmadan veya duvara bağlamadan önce duvar türünü ve gücünü kontrol edin. Duvar tipi için uygun dübelleri ve vidaları seçin. Emin değilseniz bir uzmana başvurun. Kurulum yetkili bir kişi tarafından yapılmalıdır. Kurulum üreticinin talimatlarına göre yapılmalıdır - aksi takdirde kurulumun yanlış olması ve ezilme nedeniyle ciddi veya ölümcül yaralanmaya neden olabilecek bir tehlike olabilir. UYARI !!! Bu ürünün devrilmesini önlemek için, ürünle birlikte verilen duvar bağlantı cihazı ile birlikte kullanın. Kullanırken, mobilyaların altına ağır nesnelere yerleştirin, TV'yi veya diğer ağır nesnelere üzerine koymayın ve çocukların çekmecelere, kapılara ve raflara tırmanmasına asla izin vermeyin.

UKR –

Перш ніж повісити меблі або прикріпити її до стіни, попередньо перевірте тип стіни та міцність. Виберіть відповідні дюбелі та саморізи для типу стіни. Якщо є сумніви, зверніться до фахівця. Монтаж повинен проводити компетентна особа. Установку слід проводити відповідно до інструкцій виробника - інакше може виникнути небезпека, що установка буде неправильною, що може призвести до серйозних чи смертельних травм внаслідок дроблення.

УВАГА !!! Щоб уникнути перекидання цього виробу, використовуйте його із включеним пристроєм для кріплення стіни. Під час користування кладіть важкі предмети в нижню частину меблів, не ставте на нього телевізор чи інші важкі предмети і ніколи не дозволяйте дітям лізти на ящики, двері та полиці.

PL - Mocowanie mebla do ściany / BG - Закрепване на мебелите към стената / CZ - Upevnění nábytku ke zdi / DE - Befestigung der Möbel an der Wand / EN - Fixing the furniture to the wall / ES - Fijando los muebles a la pared / EST - Mööbli kinnitamine seinale / FR - Fixation des meubles au mur / HR - Ugradnja namještaja na zid / HU - A bútorok falhoz rögzítése / I - Fissare i mobili al muro / LT - Baldų tvirtinimas prie sienos / LV - Mēbeļu piestiprināšana pie sienas / NL - Het meubilair aan de muur bevestigen / P - Fixando a mobília na parede / RO - Fixarea mobilierului pe perete / RU - Крепление мебели к стене / S - Fäster möblerna på väggen / SK - Pripevnenie nábytku k stene / SLO - Pritrditev pohištva na steno / SRB - Spajanje namještaja na zid / TR - Mobilyayı duvara sabitleme / UKR - Кріплення меблів до стіни /

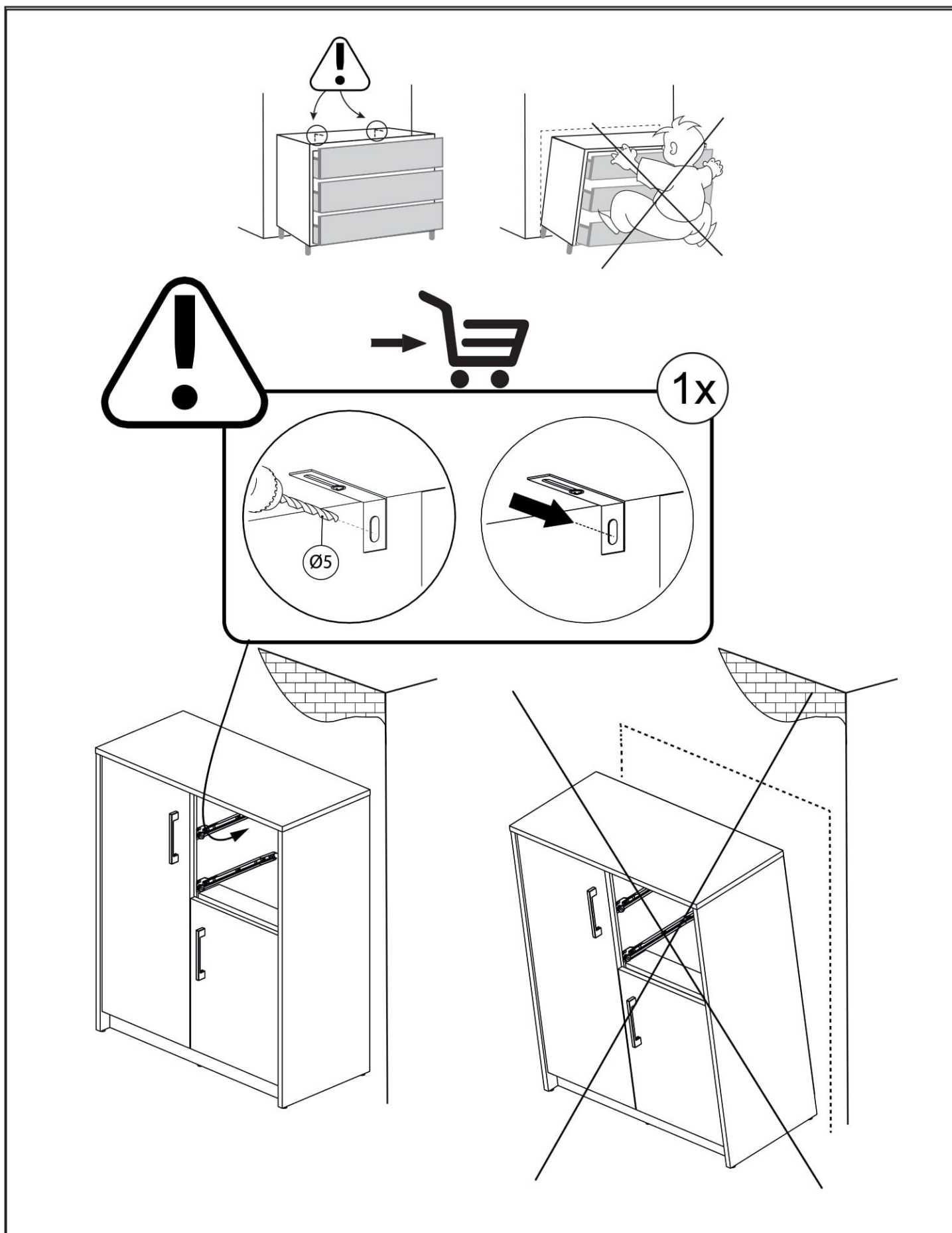

36

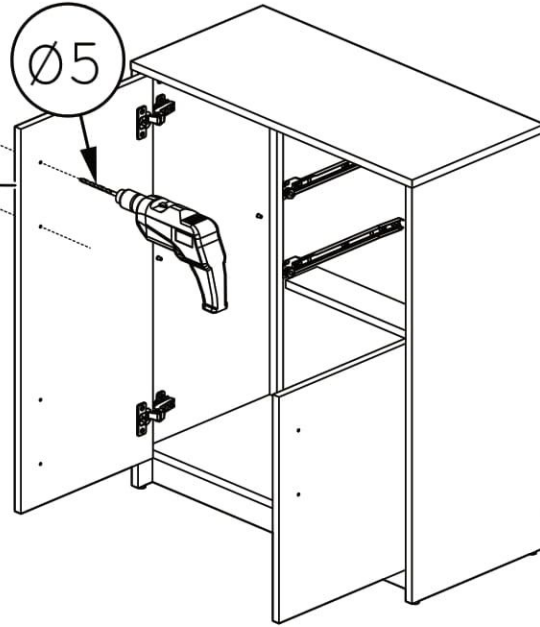
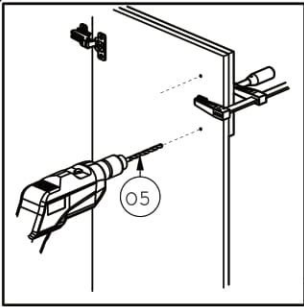
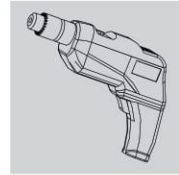

37

