

A	B	C	D	
1	S162-023	774	176	3/3
2	S162-127	1977	371	1/3
3	S162-128	1977	371	1/3
4	S162-209	800	397	2/3
5	S162-319	768	371	2/3
6	S162-320	767	370	2/3
7	S162-418	768	60	2/3
8	S162-419	768	60	2/3
9	S162-420	768	60	2/3
10	S162-919	1942	793	1/3
11	S162-920	741	355	1/3
12	ZS3-509	350	120	2/3
13	ZS3-510	350	120	2/3
14	ZS3-5524	719	120	2/3

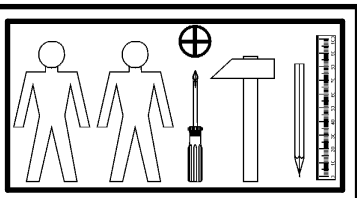

12x Ø5x17 mm d1	4x Ø7x50 mm e1	8x Ø5x9 mm e19	12x Ø6x13 mm e3	16x Ø8x30 mm f1	8x Ø6.5x40 mm f25	4x k1	65x l1	2x Ø3.5x16 mm p25
2x Ø3.5x10 mm p35	12x Ø3.5x16 mm p38	8x Ø15x12 mm #16 r1	8x Ø12x10.5 mm #12 r15	16x r42	2x 350 mm t35	2x 350 mm w45\CL	2x 350 mm w45\CR	2x 350 mm w45\DL
2x 350 mm w45\DR	1x z1	1x n26\1	1x Ø3.5x16 mm p38					

# 1

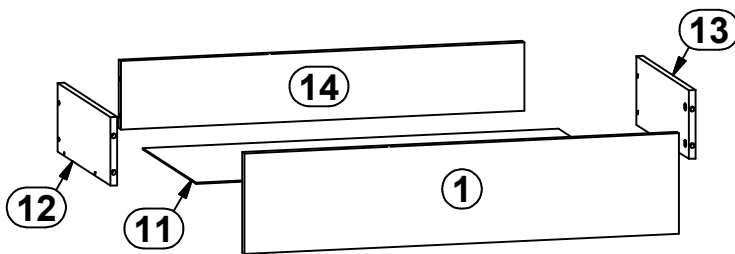
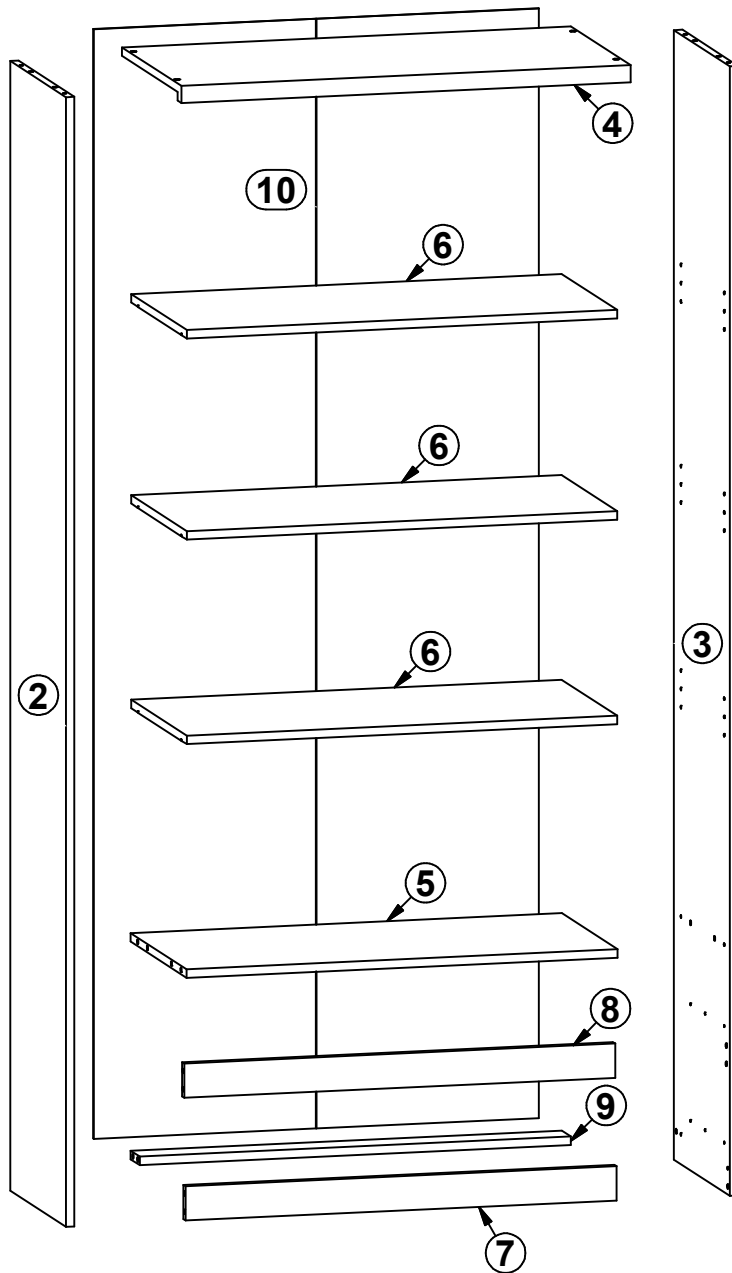
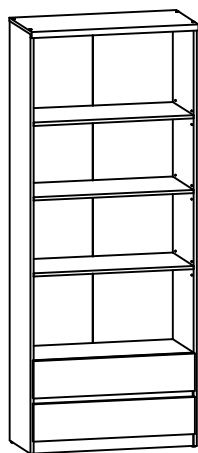
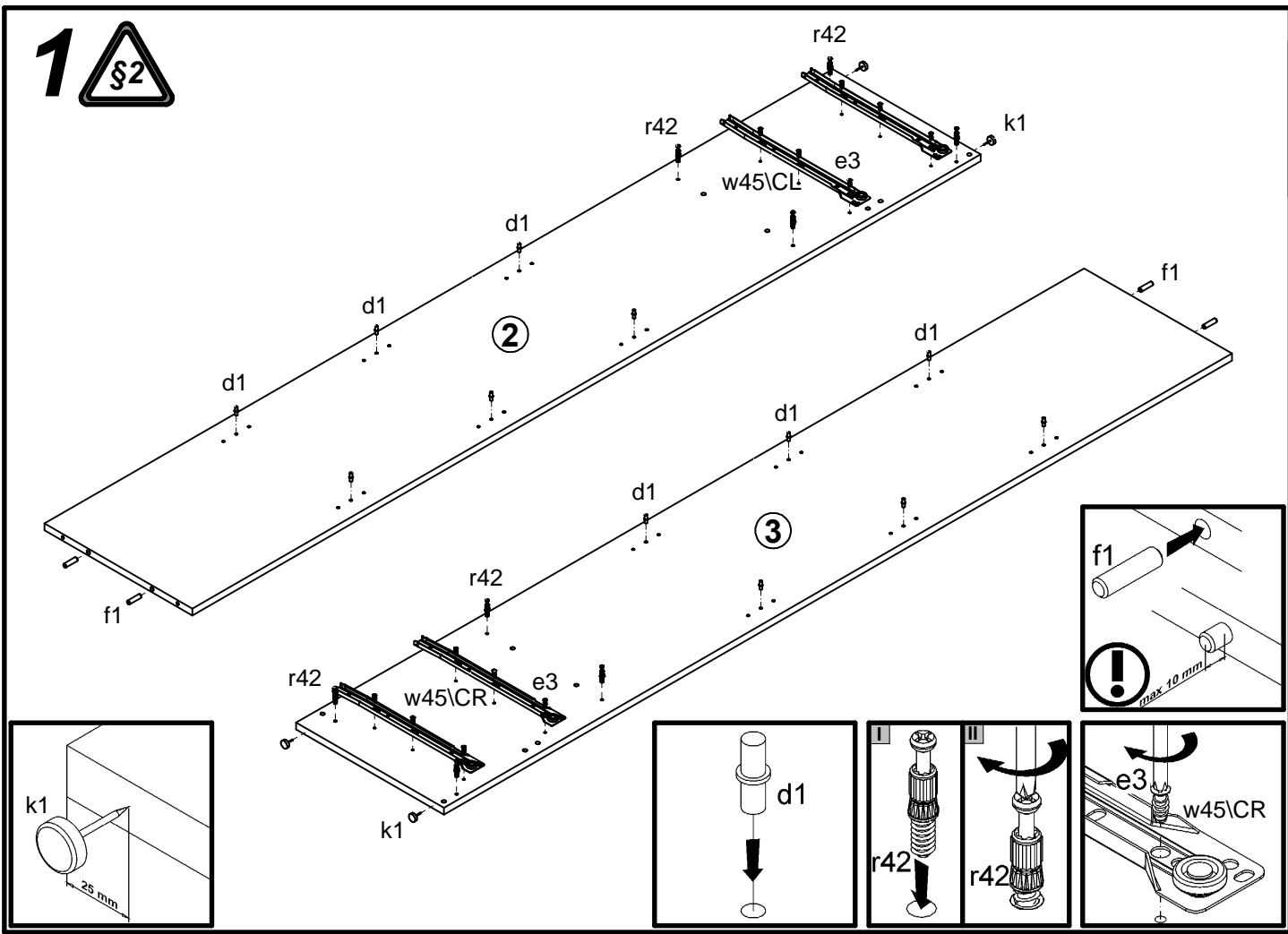

# 2

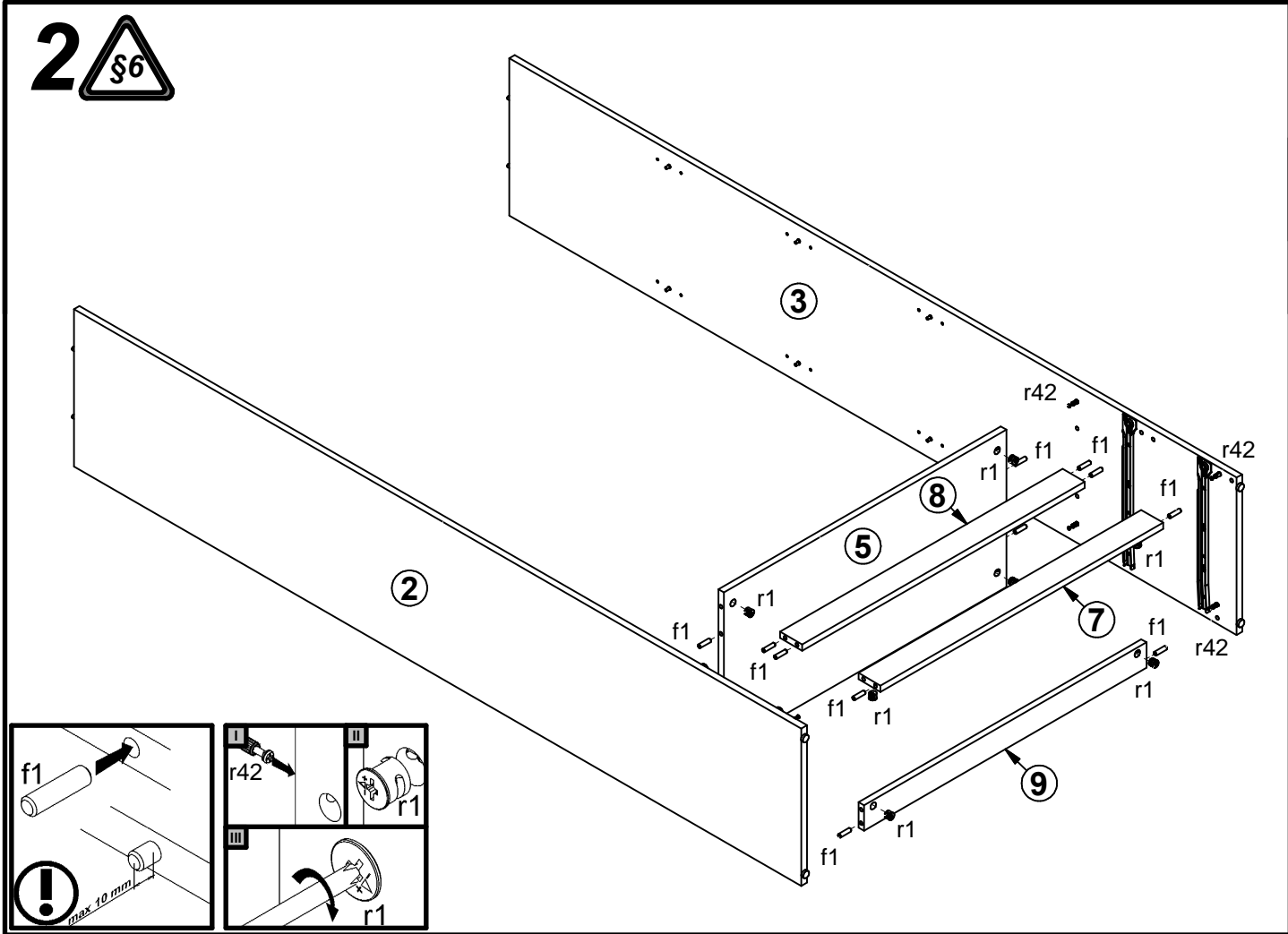

# 3

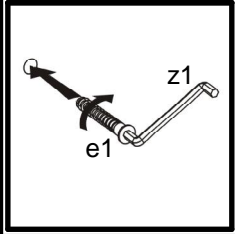
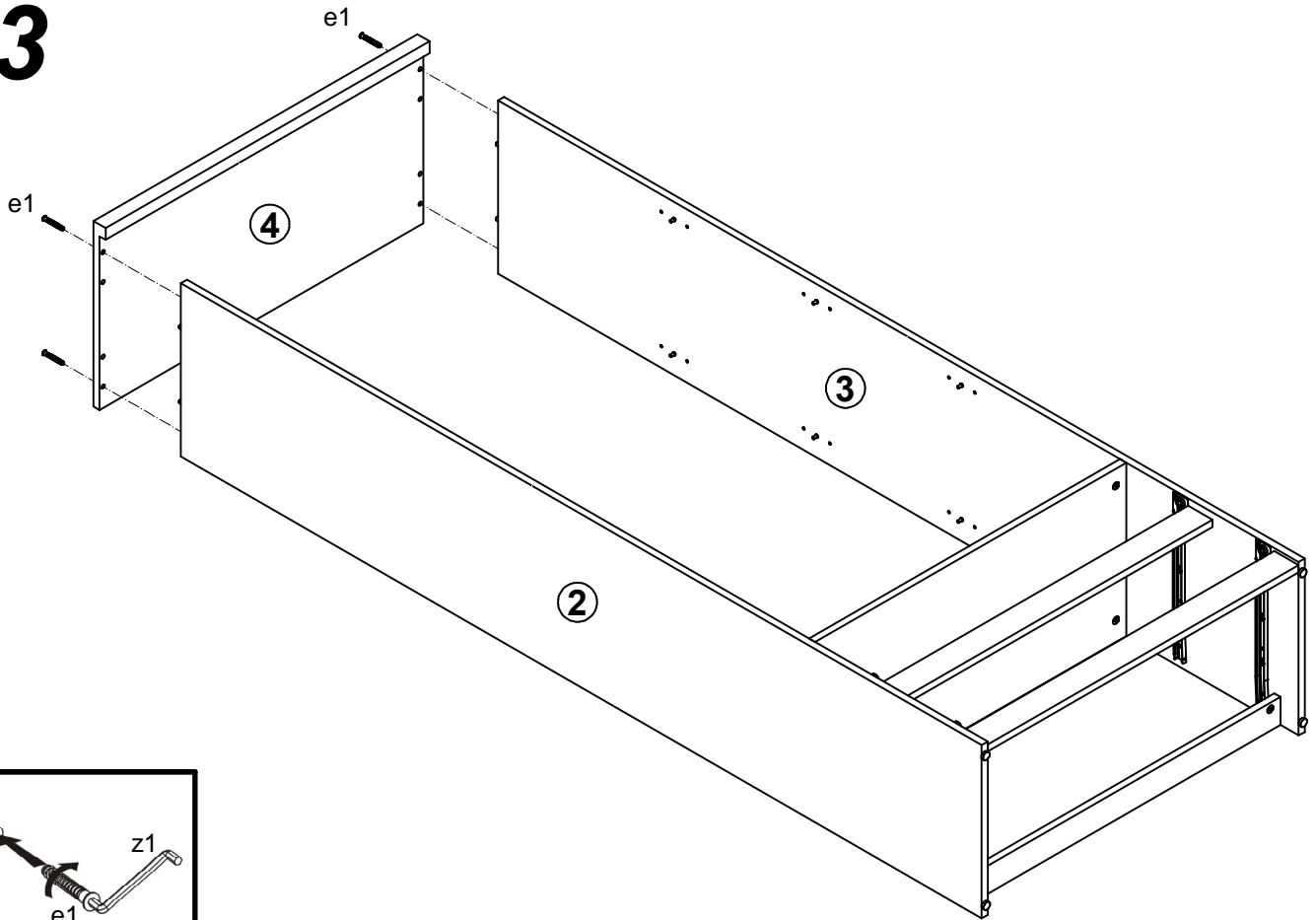

# 4

